

NEW PRODUCT NEWS



Multi-Functional Grooving tools

FLO CUT

FACE GROOVING DEEP GROOVING INTERNAL AND EXTERNAL APPLICATIONS

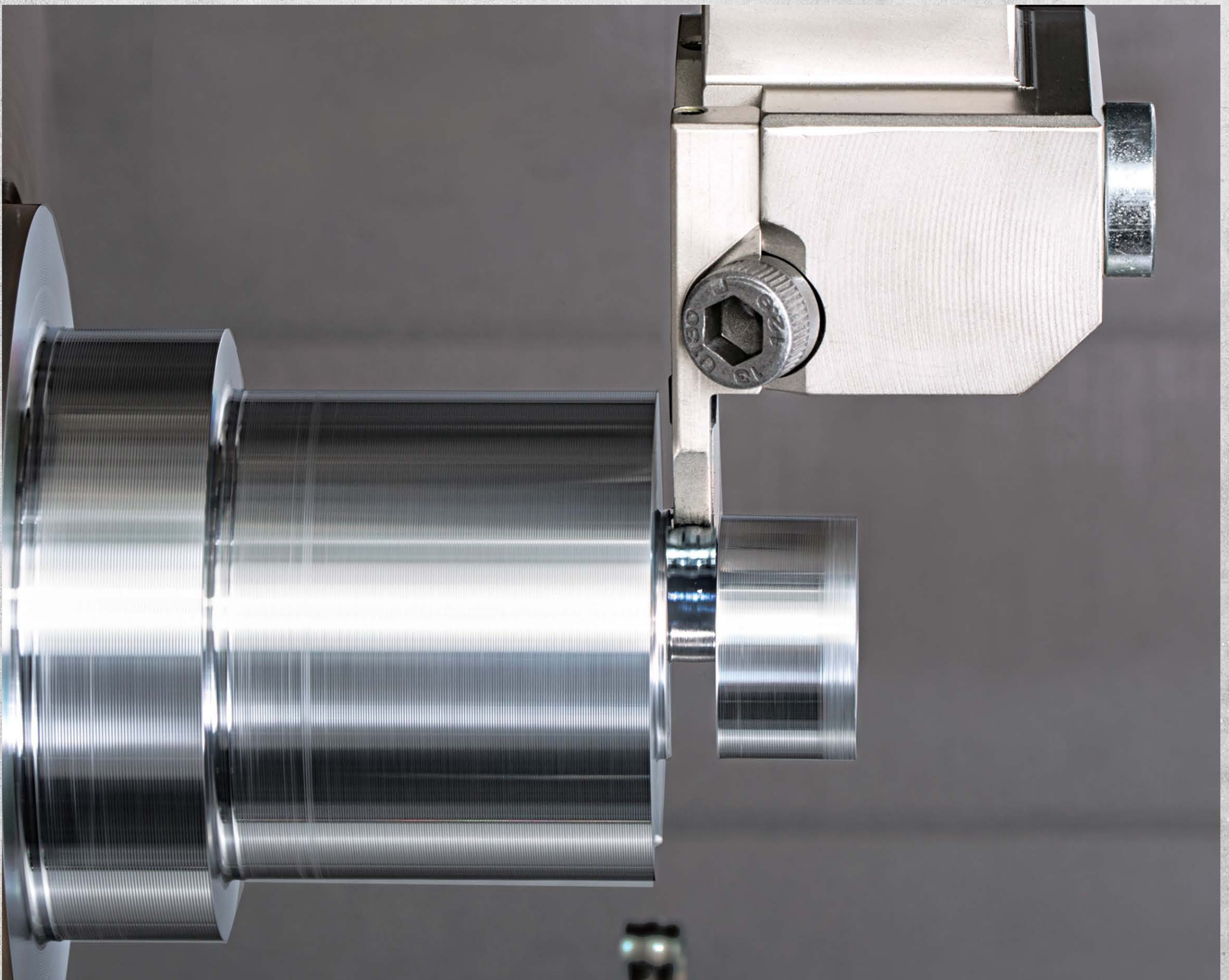

NEW PRODUCT NEWS



Multi-Functional Grooving tools



FLO CUT

MULTI-FUNCTIONAL GROOVING TOOLS

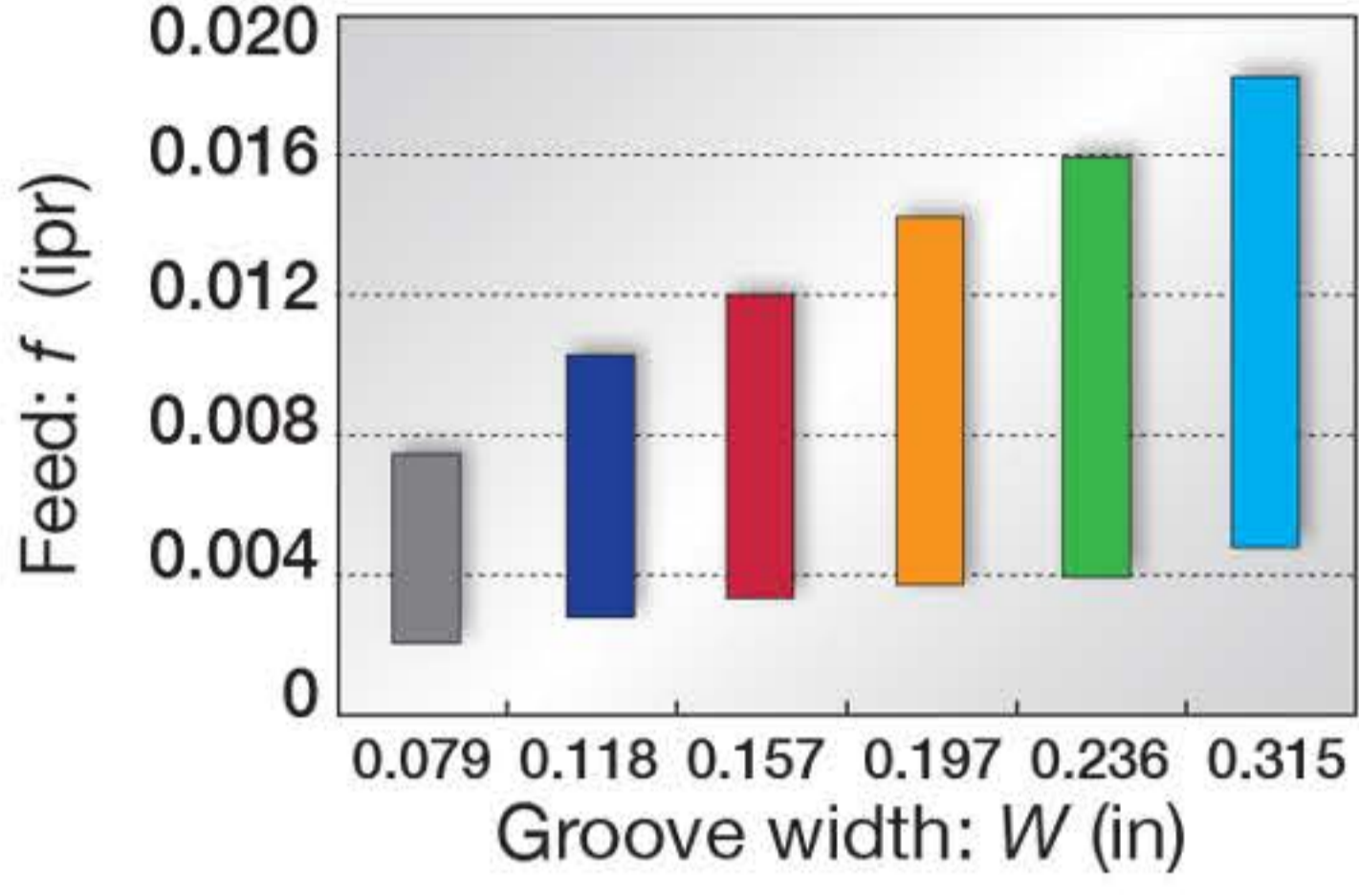
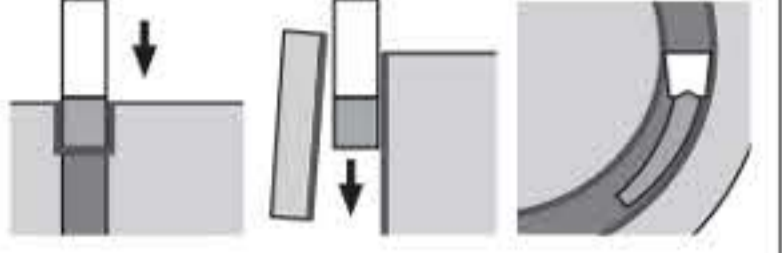

External grooving and parting

- Chipbreaker Guide

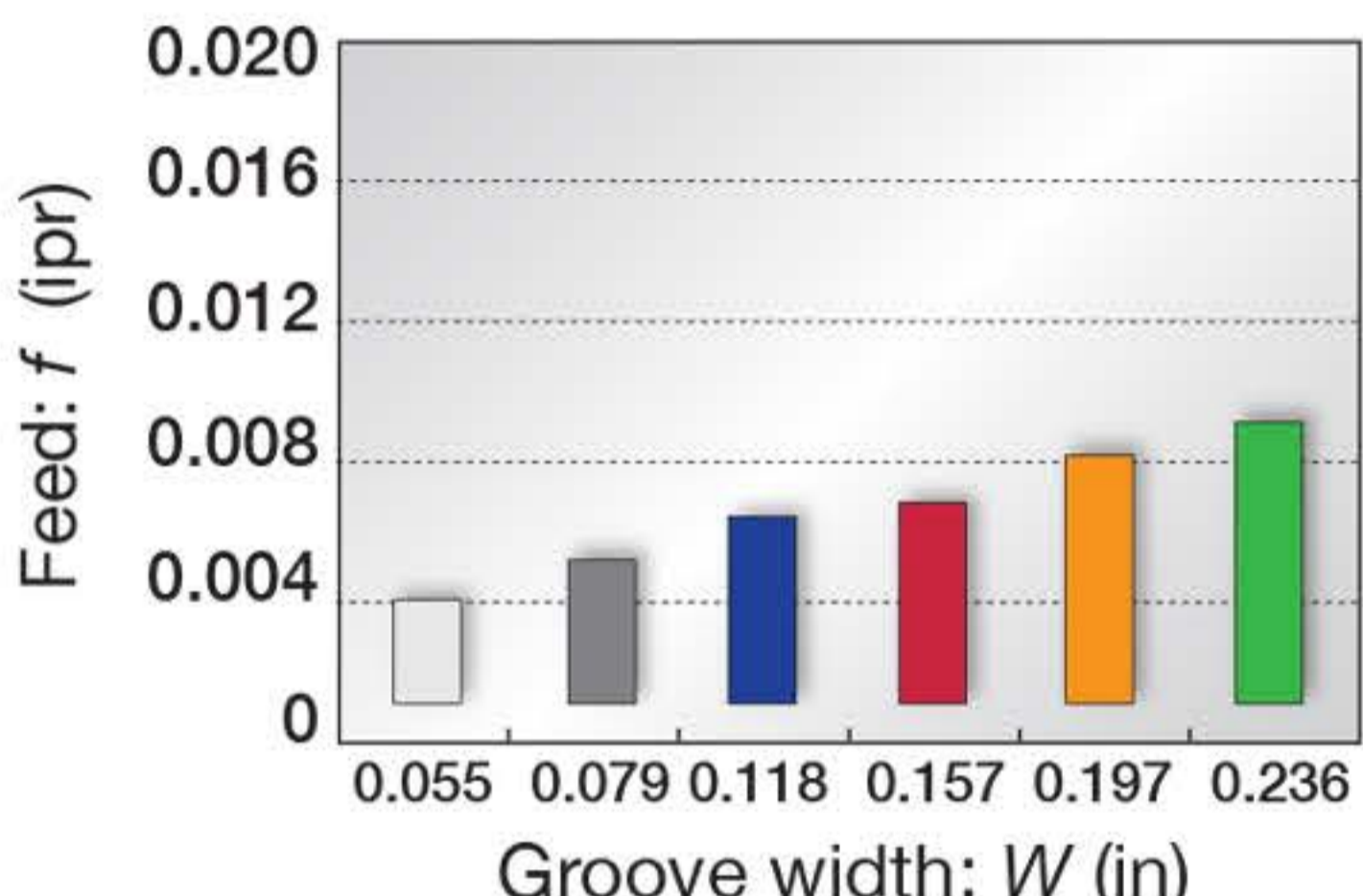
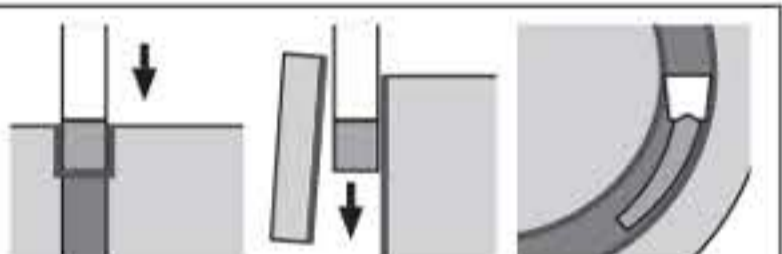
<p>FDM type (2 corners) FSM type (1 corner)</p>  <p>Pages 6, 7</p>	<p>1st choice for external grooving and parting off</p> <p>Smooth chip evacuation</p> <p>Well-designed edge with high strength</p> <p>Handed insert available</p> <p>$W = 0.079'' - 0.315''$</p>	<p>Standard feed</p>  
<p>FDS type (2 corners) FSS type (1 corner)</p>  <p>Pages 7, 8</p>	<p>Lower cutting force and superior sharpness</p> <p>Unique-designed edge and chipbreaker</p> <p>Handed insert available</p> <p>$W = 0.055'' - 0.236''$</p>	<p>Standard feed</p>  

External and face grooving, and turning

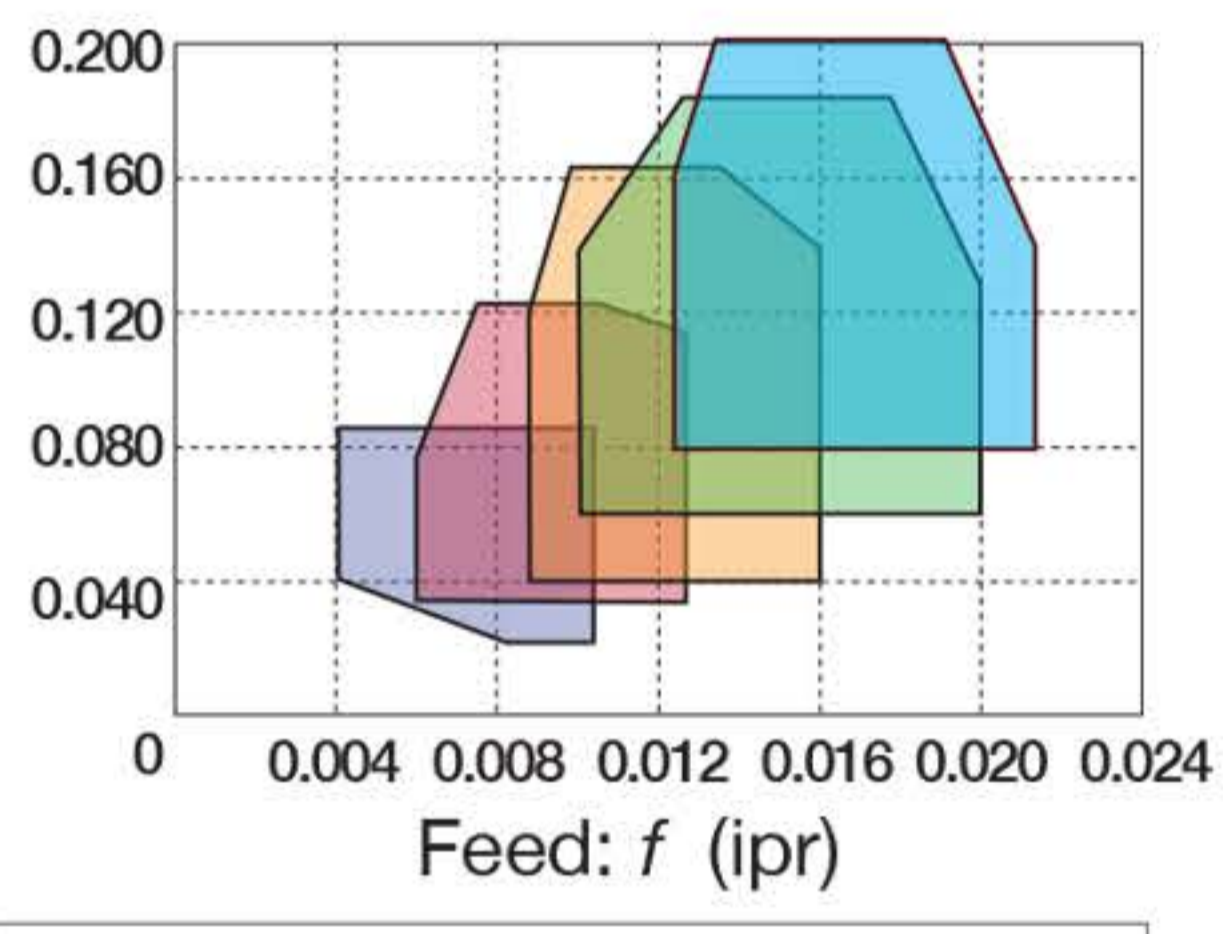
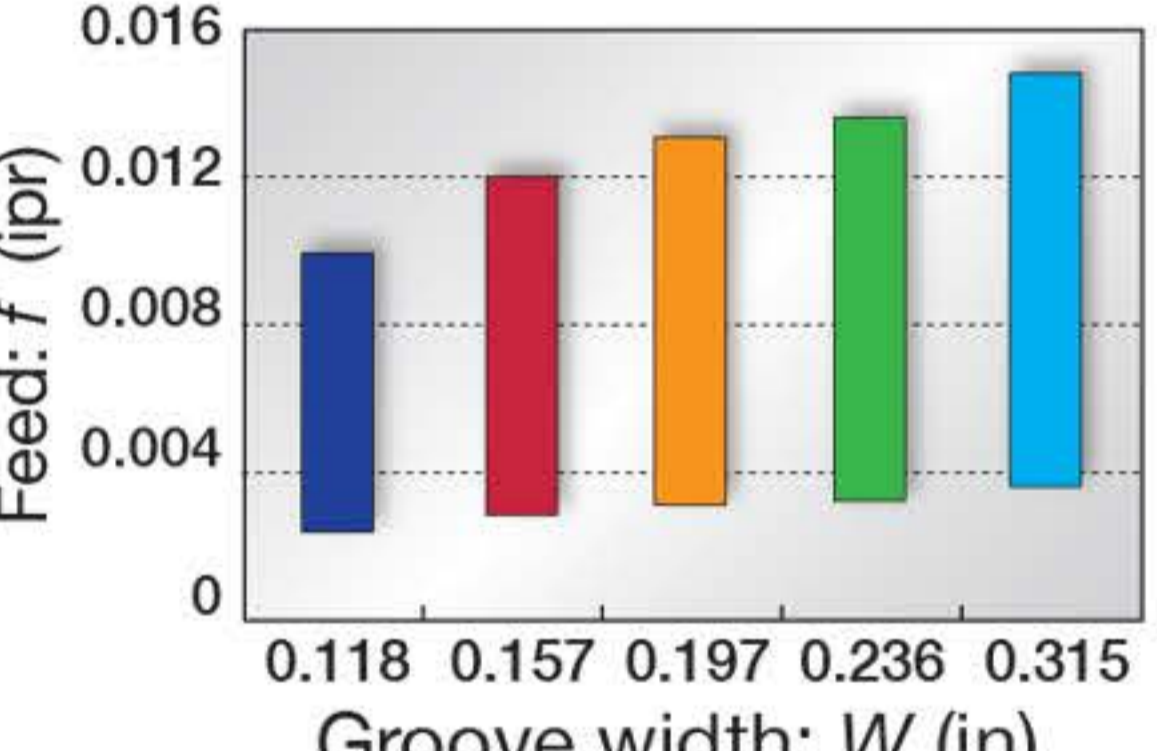
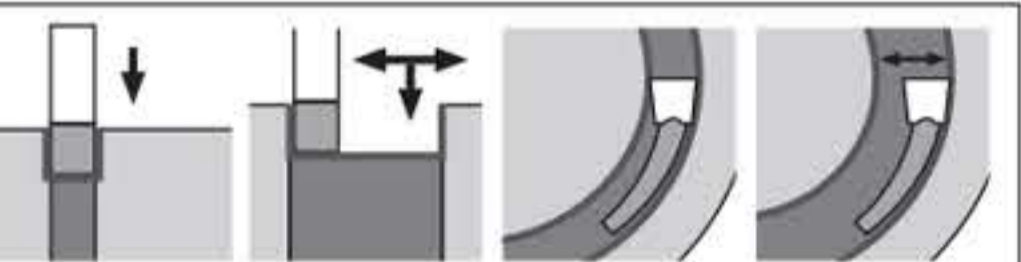
<p>FDE type (2 corners)</p>  <p>Page 8, 9</p>	<p>For general purpose</p> <p>Unique chipbreaker makes chips shorter</p> <p>Molded and ground insert available</p> <p>$W = 0.104'' - 0.315''$</p>	<p>Standard feed and DoC</p>  <p>Standard feed</p>  
---	--	---

External grooving

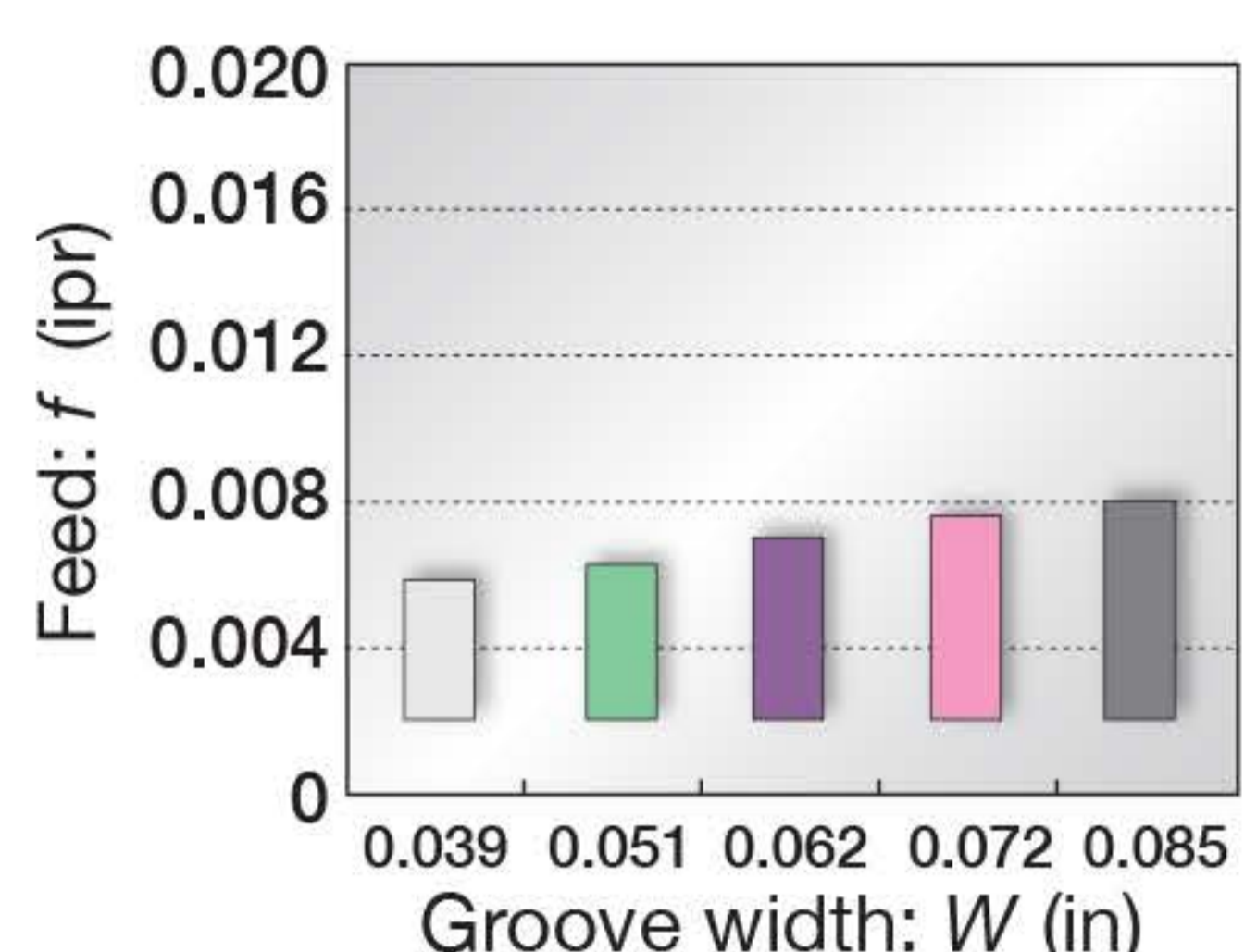
<p>FDET type (2 corners)</p>  <p>Page 9</p>	<p>For high accurate and shallow groove</p> <p>Excellent chip control</p> <p>$W = 0.039'' - 0.085''$</p>	<p>■ Standard feed</p> 
---	---	--

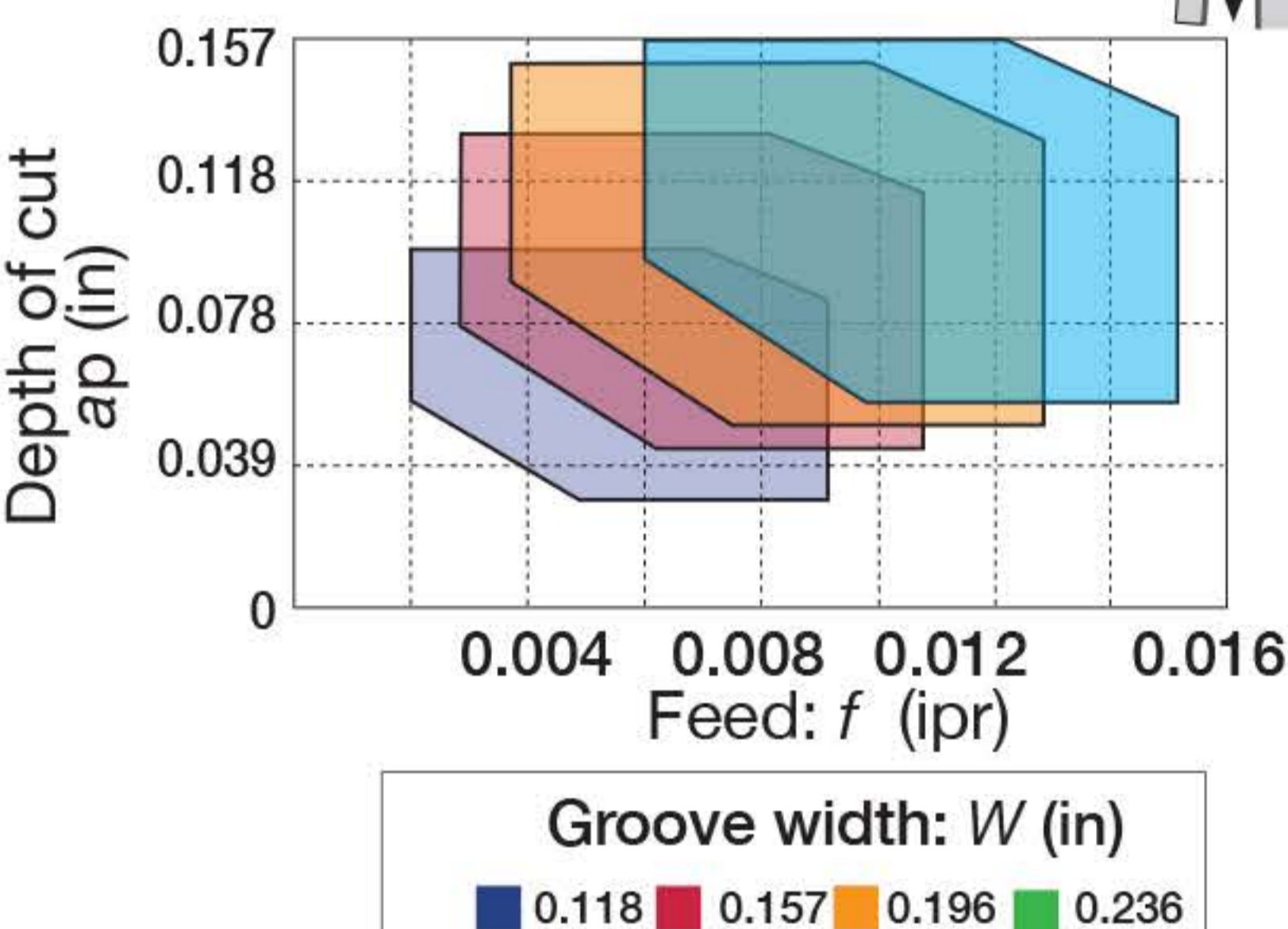
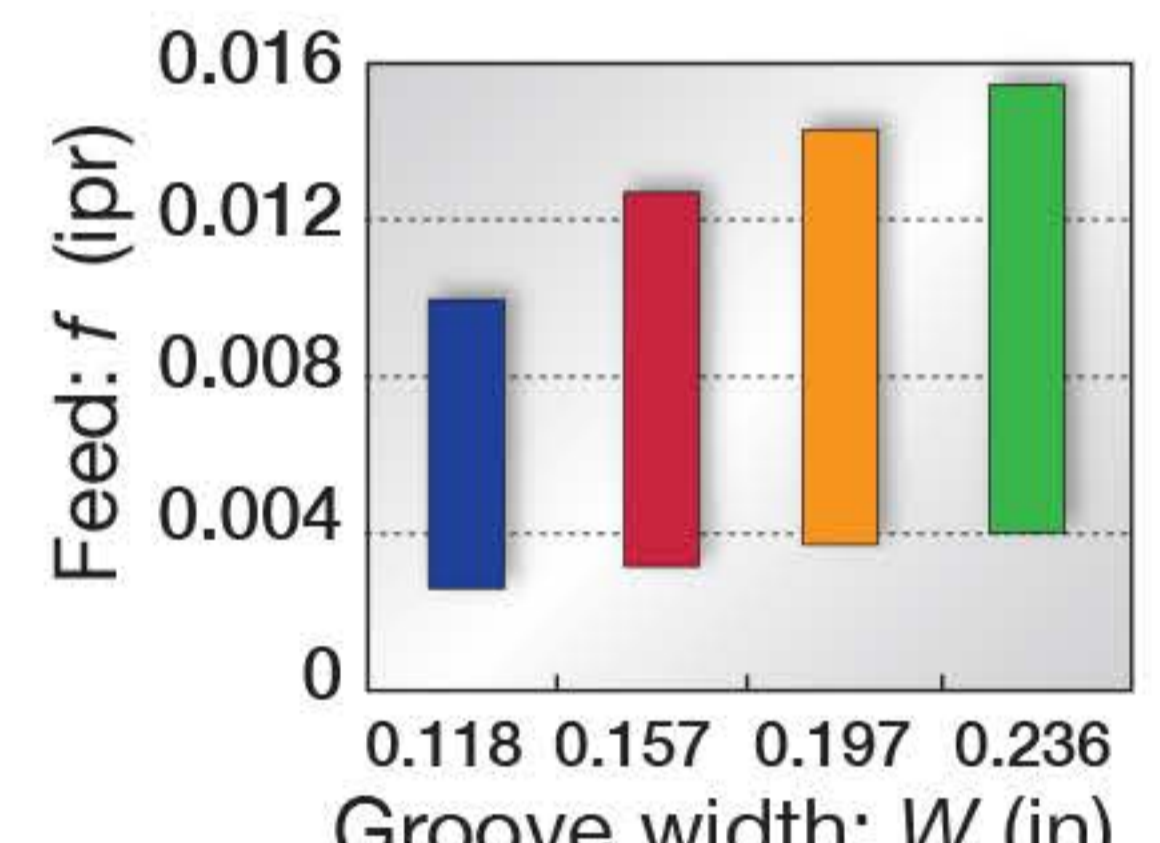

External, internal and face grooving, and turning

<p>FDX type (2 corners)</p>  <p>Page 10</p>	<p>Multi-functional type</p> <p>Well balanced sharpness and strength</p> <p>Multi functional insert</p> <p>$W = 0.118'' - 0.236''$</p>	<p>■ Standard feed and DoC</p>  <p>■ Standard feed</p> 
---	---	---

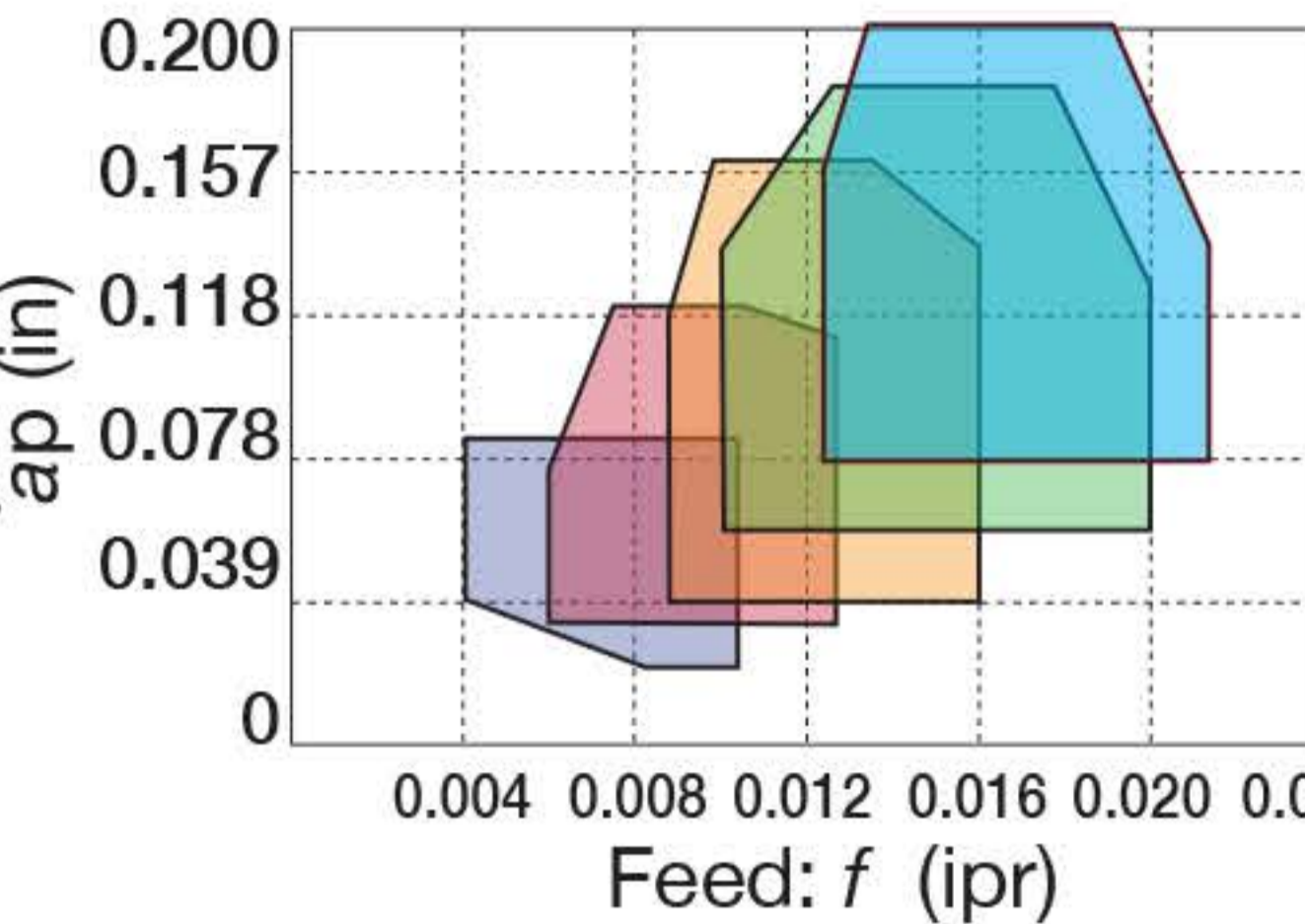
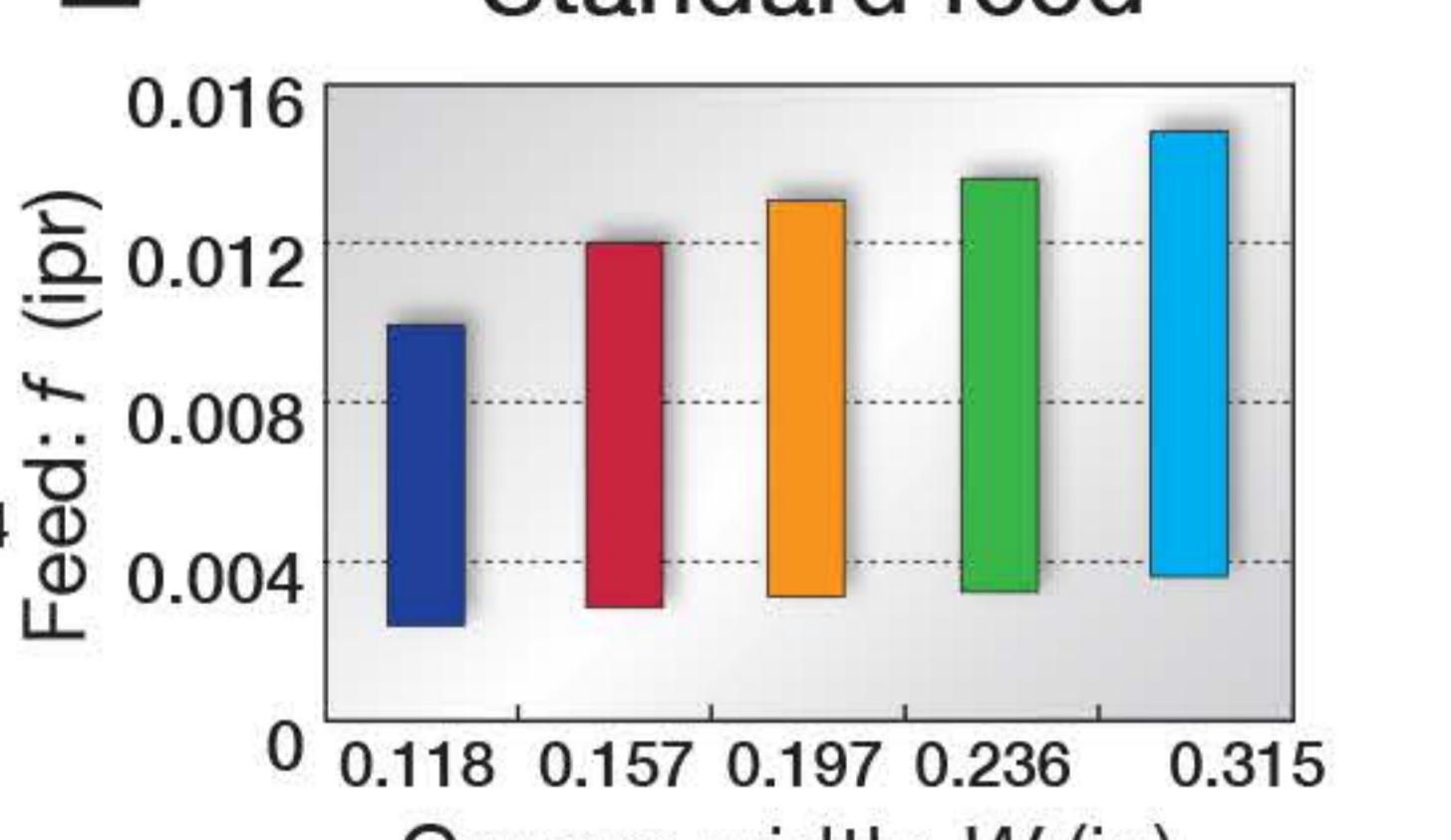
Internal grooving and turning

<p>FDIE type (2 corners)</p>  <p>Page 10, 11</p>	<p>1st choice for internal grooving</p> <p>Unique chipbreaker makes chips shorter</p> <p>Molded and ground insert available</p> <p>$W = 0.118'' - 0.315''$</p>	<p>Standard feed and DoC</p>  <p>Standard feed</p> 
--	---	---

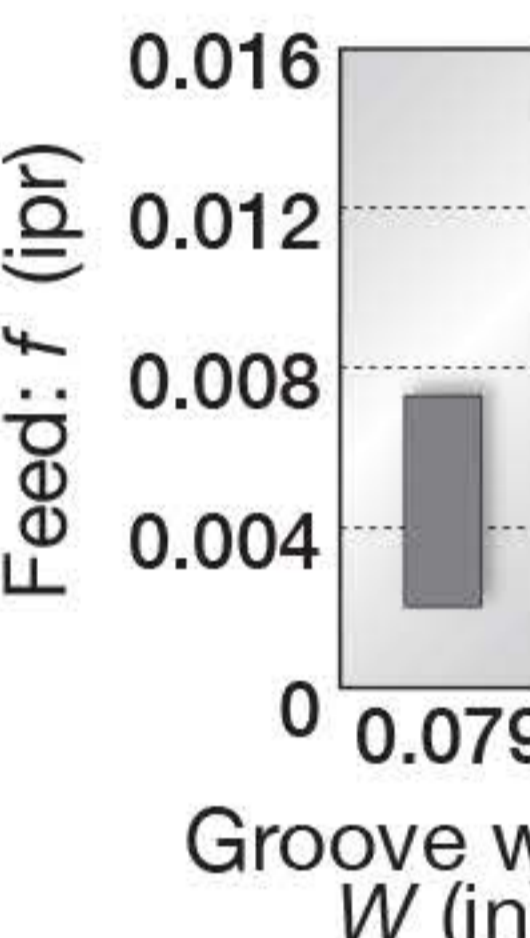
Small diameter internal grooving

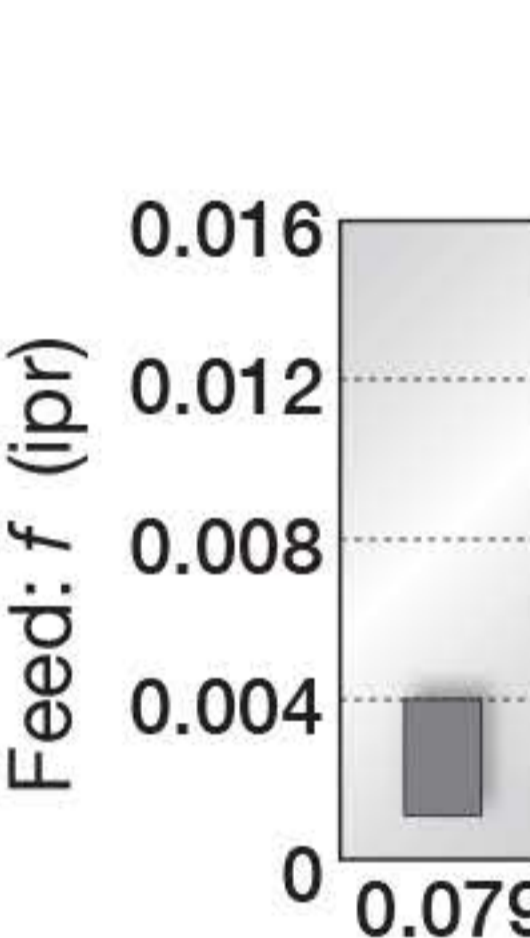
<p>FDIM type (2 corners)</p>  <p>Page 11</p>	<p>2 mm insert width only (For general purpose)</p> <p>Unique chipbreaker for excellent chip control</p> <p>Excellent fracture resistance due to optimum land on the cutting edge</p> <p>For general applications on steels & stainless steels</p> <p>$W = 0.079''$</p>	<p>Standard feed</p> 
<p>FDIS type (2 corners)</p>  <p>Page 11</p>	<p>2 mm insert width only (Lower cutting force)</p> <p>Low cutting force due to a unique land geometry</p> <p>Applicable for low carbon steels & stainless steels</p> <p>$W = 0.079''$</p>	<p>Standard feed</p> 

Face grooving and turning

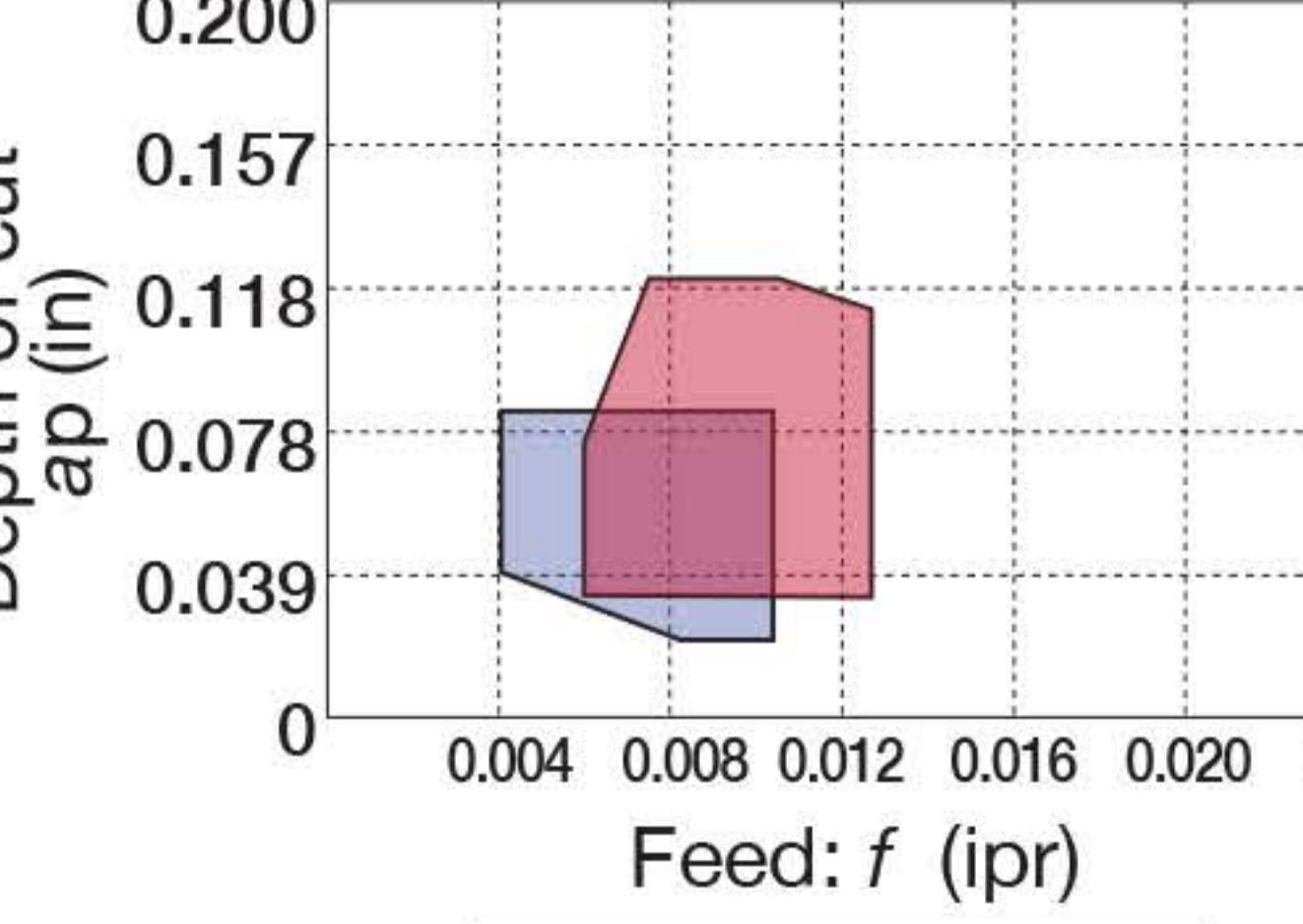
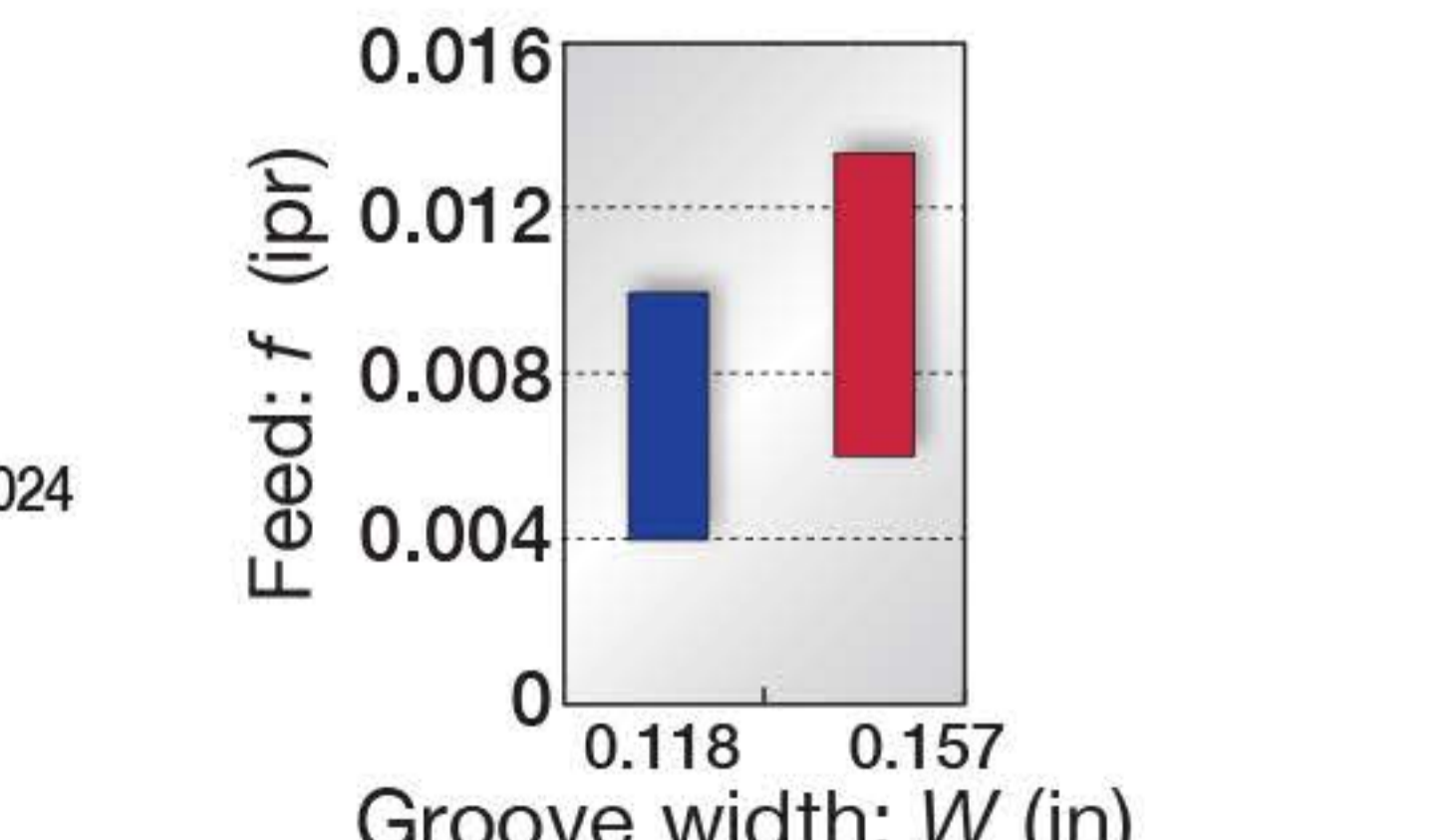
<p>FDF type (2 corners)</p>  <p>Page 12</p>	<p>1st choice for face grooving</p> <p>Unique chipbreaker makes chips shorter</p> <p>Handed insert</p> <p>$W = 0.118'' - 0.157''$</p>	<p>Standard feed and DoC</p>  <p>Standard feed</p> 
---	--	---

Multi-Functional Grooving tools

FCER/L

Blades for external grooving & parting & turning

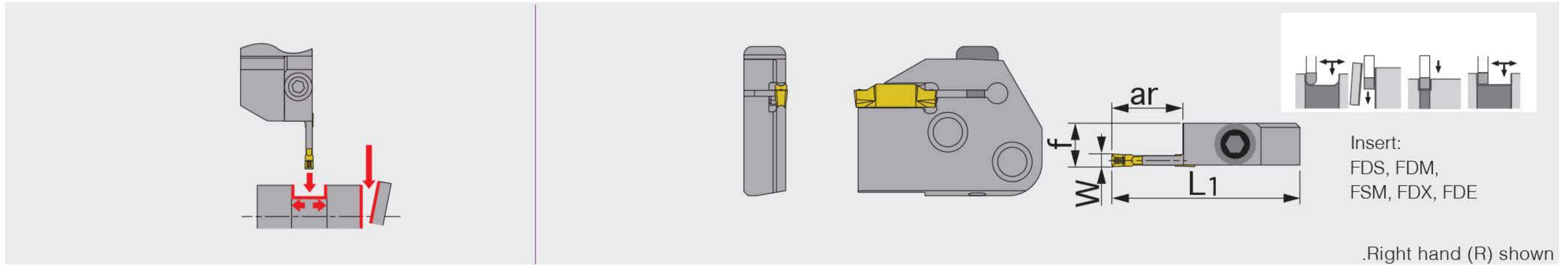

Description	W (in)	W (mm)	Seat size	ar	L ₁	f	Shank
FCER/L-3T16	0.118	3	3	0.630 (16.00)	1.772 (45.01)	0.409 (10.39)	...FHFL/R...,FHCR/L
FCER/L-4T16	0.157	4	4	0.630 (16.00)	1.772 (45.01)	0.413 (10.49)	...FHFL/R...,FHCR/L
FCER-5T20	0.197	5	5	0.787 (19.99)	1.949 (49.51)	0.413 (10.49)	...FHFL/R...,FHCR/L

SPARE PARTS

Designation	Clamping screw	Wrench
...CAER/L	BHM6-20-A	P-4

FBE

Blades for external deep grooving & parting

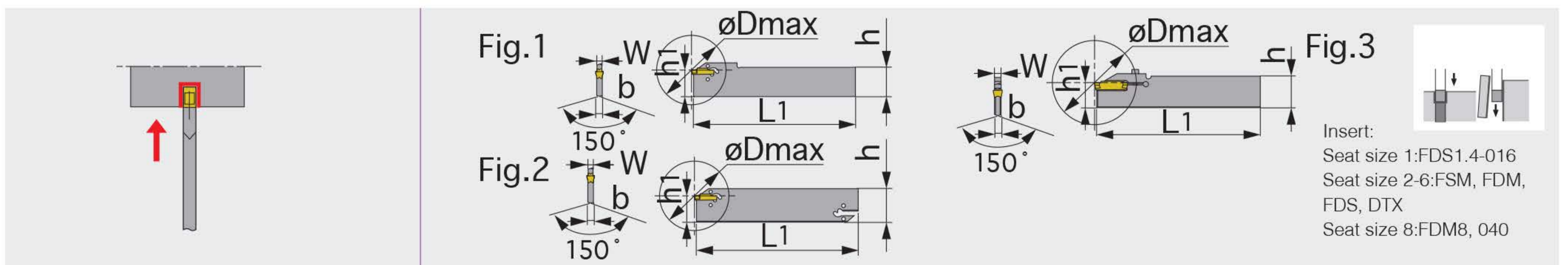

Description	W (in)	W (mm)	Seat size	øD _{max}	h ₁	b	h	L ₁	Fig
FBE26-1.4S	0.055	1.4	1	1.024 (26.01)	0.843 (21.41)	0.039 (0.99)	1.024 (26.01)	5.906 (150.01)	1
FBE32-1.4D	0.055	1.4	1	1.024 (26.01)	0.976 (24.79)	0.039 (0.99)	1.260 (32.00)	5.906 (150.01)	2
FBE26-2S	0.079	2	2	1.575 (40.01)	0.843 (21.41)	0.071 (1.80)	1.024 (26.01)	5.906 (150.01)	1
FBE32-2D	0.079	2	2	1.969 (50.01)	0.976 (24.79)	0.071 (1.80)	1.260 (32.00)	5.906 (150.01)	2
FBE26-3S	0.118	3	3	1.969 (50.01)	0.843 (21.41)	0.094 (2.39)	1.024 (26.01)	5.906 (150.01)	1
FBE32-3D	0.118	3	3	3.937 (100.00)	0.976 (24.79)	0.094 (2.39)	1.260 (32.00)	5.906 (150.01)	2
FBE26-4S	0.157	4	4	3.150 (80.01)	0.844 (21.44)	0.126 (3.20)	1.024 (26.01)	5.906 (150.01)	1
FBE32-4D	0.157	4	4	3.937 (100.00)	0.980 (24.89)	0.126 (3.20)	1.260 (32.00)	5.906 (150.01)	2
FBE45-4D	0.157	4	4	4.724 (119.99)	1.500 (38.10)	0.126 (3.20)	1.772 (45.01)	5.906 (150.01)	2
FBE32-5D	0.197	5	5	4.724 (119.99)	0.980 (24.89)	0.156 (3.96)	1.260 (32.00)	5.906 (150.01)	2
FBE32-6D	0.236	6	6	4.724 (119.99)	0.980 (24.89)	0.203 (5.16)	1.260 (32.00)	5.906 (150.01)	2
FBE32-8S-CL	0.315	8	8	3.150 (80.01)	0.980 (24.89)	0.244 (6.20)	1.260 (32.00)	5.906 (150.01)	3

- When depth is deeper than (insert length - 0.059"), 1 corner type is recommended.
- Wrench (CRW**) should be ordered separately.
- Max groove depth is 1.122".
- øD_{max}: Max. parting off dia.

SPARE PARTS

Designation	Clamping screw	Wrench
FBE**-1.4*	-	CRW23
FBE**-2/3/4/5/6	-	CRW33
FBE32-8S-CL	CM4X0.7X20-M0-A	P-3

Multi-Functional Grooving tools

FDM

External grooving and parting off, 2 corner

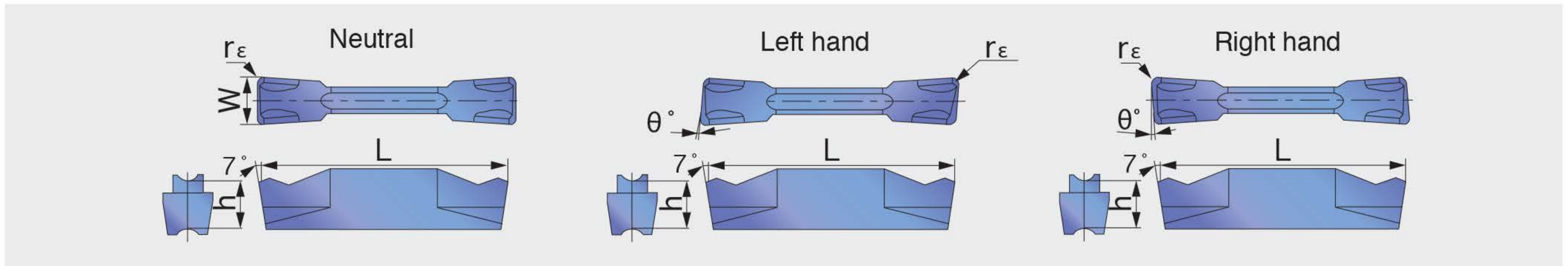

Designation	Insert seat size	W±0.05 (mm)	W±0.002 (in)	rε (in)	Grade		L (in)	h (in)	°θ
					AC22	TP222			
FDM2-020	2	2	0.079 (2.01)	0.008 (0.20)	●	●	0.787 (19.99)	0.197 (5.00)	0
FDM2-020-6R/L	2	2	0.079 (2.01)	0.008 (0.20)	●	●	0.787 (19.99)	0.197 (5.00)	6
FDM2-020-8R/L	2	2	0.079 (2.01)	0.008 (0.20)	●	●	0.787 (19.99)	0.197 (5.00)	8
FDM2-020-15R/L	2	2	0.079 (2.01)	0.008 (0.20)	●	●	0.787 (19.99)	0.197 (5.00)	15
FDM2-002-15R/L	2	2	0.079 (2.01)	0.0008 (0.02)	●	●	0.772 (19.61)	0.197 (5.00)	15
FDM3-020	3	3	0.118 (3.00)	0.008 (0.20)	●	●	0.787 (19.99)	0.197 (5.00)	0
FDM3-020-6R/L	3	3	0.118 (3.00)	0.008 (0.20)	●	●	0.787 (19.99)	0.197 (5.00)	6
FDM3-002-6R/L	3	3	0.118 (3.00)	0.0008 (0.02)	●	●	0.772 (19.61)	0.197 (5.00)	6
FDM3-020-15R/L	3	3	0.118 (3.00)	0.008 (0.20)	●	●	0.787 (19.99)	0.197 (5.00)	15
FDM4-030	4	4	0.157 (3.99)	0.012 (0.31)	●	●	0.787 (19.99)	0.197 (5.00)	0
FDM4-030-4R/L	4	4	0.157 (3.99)	0.012 (0.31)	●	●	0.787 (19.99)	0.197 (5.00)	4
FDM4-030-15R/L	4	4	0.157 (3.99)	0.012 (0.31)	●	●	0.787 (19.99)	0.197 (5.00)	15
FDM5-030	5	5	0.197 (5.00)	0.012 (0.31)	●	●	0.984 (24.99)	0.217 (5.51)	0
FDM5-030-4R	5	5	0.197 (5.00)	0.012 (0.31)			0.787 (19.99)	0.217 (5.51)	4
FDM6-030	6	6	0.236 (5.99)	0.012 (0.31)	●	●	0.984 (24.99)	0.217 (5.51)	0
FDM8-040	8	8	0.315 (8.00)	0.016 (0.41)	●	●	1.181 (30.00)	0.264 (6.71)	0

● : Line up

Multi-Functional Grooving tools

FSM

External deep grooving and parting off, 1 corner

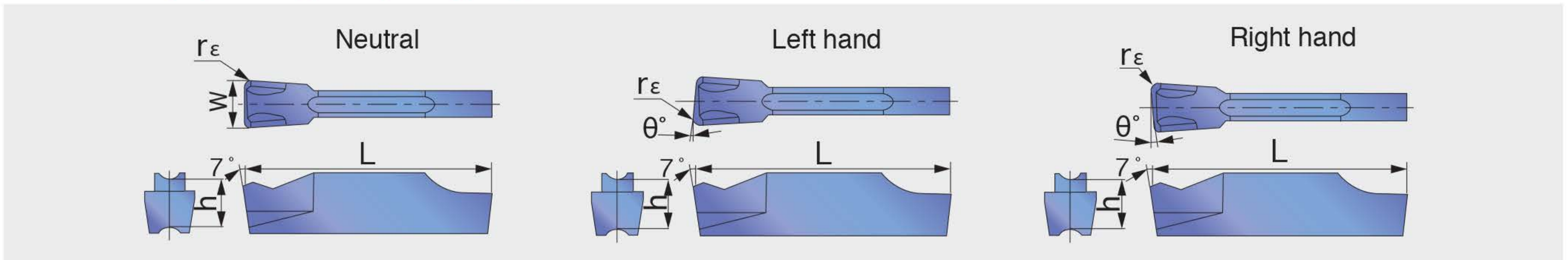

Designation	Insert seat size	W±0.05 (mm)	W±0.002 (in)	rε (in)	Grade		L (in)	h (in)	°θ
					AC22	TP222			
FSM2-020	2	2	0.079 (2.01)	0.008 (0.20)	●	●	0.787 (19.99)	0.197 (5.00)	0
FSM2-020-6R/L	2	2	0.079 (2.01)	0.008 (0.20)	●	●	0.787 (19.99)	0.197 (5.00)	6
FSM3-020	3	3	0.118 (3.00)	0.008 (0.20)	●	●	0.787 (19.99)	0.197 (5.00)	0
FSM3-020-6R/L	3	3	0.118 (3.00)	0.008 (0.20)	●	●	0.787 (19.99)	0.197 (5.00)	6
FSM3-020-15R/L	3	3	0.118 (3.00)	0.008 (0.20)	●	●	0.787 (19.99)	0.197 (5.00)	15
FSM4-030	4	4	0.157 (3.99)	0.012 (0.31)	●	●	0.787 (19.99)	0.197 (5.00)	0
FSM4-030-4R/L	4	4	0.157 (3.99)	0.012 (0.31)	●	●	0.787 (19.99)	0.197 (5.00)	4
FSM5-030	5	5	0.197 (5.00)	0.012 (0.31)	●	●	0.984 (24.99)	0.217 (5.51)	0
FSM6-030	6	6	0.236 (5.99)	0.012 (0.31)	●	●	0.984 (24.99)	0.217 (5.51)	0

● : Line up

FDS

External grooving and parting off, 2 corner

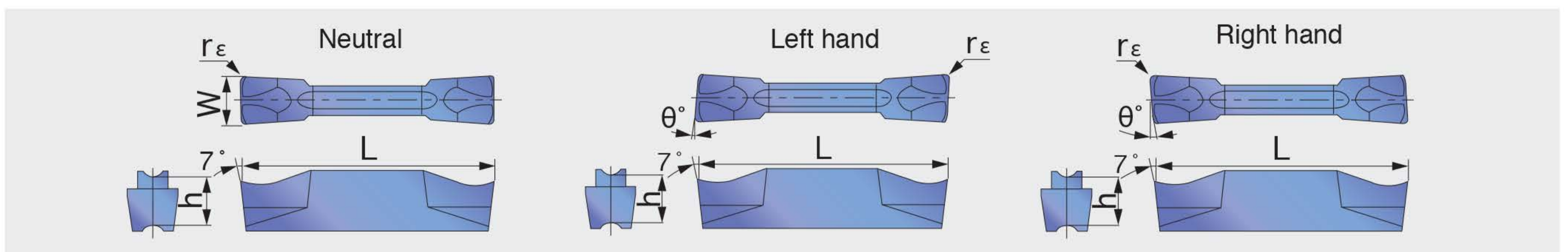

Designation	Insert seat size	W±0.05 (mm)	W±0.002 (in)	rε (in)	Grade		L (in)	h (in)	°θ
					AC22	TP222			
FDS1.4-016	1	1.4	0.055 (1.40)	0.006 (0.15)	●	●	0.630 (16.00)	0.169 (4.29)	0
FDS2-020	2	2	0.079 (2.01)	0.008 (0.20)	●	●	0.787 (19.99)	0.197 (5.00)	0
FDS2-020-6R/L	2	2	0.079 (2.01)	0.008 (0.20)	●	●	0.787 (19.99)	0.197 (5.00)	6
FDS2-002-6R/L	2	2	0.079 (2.01)	0.0008 (0.02)	●	●	0.772 (19.61)	0.197 (5.00)	6
FDS2-020-15R/L	2	2	0.079 (2.01)	0.008 (0.20)	●	●	0.787 (19.99)	0.197 (5.00)	15
FDS2-002-15R/L	2	2	0.079 (2.01)	0.0008 (0.02)	●	●	0.772 (19.61)	0.197 (5.00)	15
FDS3-020	3	3	0.118 (3.00)	0.008 (0.20)	●	●	0.787 (19.99)	0.197 (5.00)	0
FDS3-020-6R/L	3	3	0.118 (3.00)	0.008 (0.20)	●	●	0.787 (19.99)	0.197 (5.00)	6
FDS3-002-6R/L	3	3	0.118 (3.00)	0.0008 (0.02)	●	●	0.772 (19.61)	0.197 (5.00)	6
FDS3-020-15R/L	3	3	0.118 (3.00)	0.008 (0.20)	●	●	0.787 (19.99)	0.197 (5.00)	15
FDS3-002-15R/L	3	3	0.118 (3.00)	0.0008 (0.02)	●	●	0.772 (19.61)	0.197 (5.00)	15
FDS4-030	4	4	0.157 (3.99)	0.012 (0.31)	●	●	0.787 (19.99)	0.197 (5.00)	0
FDS4-030-4R/L	4	4	0.157 (3.99)	0.012 (0.31)	●	●	0.787 (19.99)	0.197 (5.00)	4
FDS5-030	5	5	0.197 (5.00)	0.012 (0.31)	●	●	0.984 (24.99)	0.217 (5.51)	0
FDS6-030	6	6	0.236 (5.99)	0.012 (0.31)	●	●	0.984 (24.99)	0.217 (5.51)	0

Multi-Functional Grooving tools

FSS

External deep grooving and parting off, 1 corner

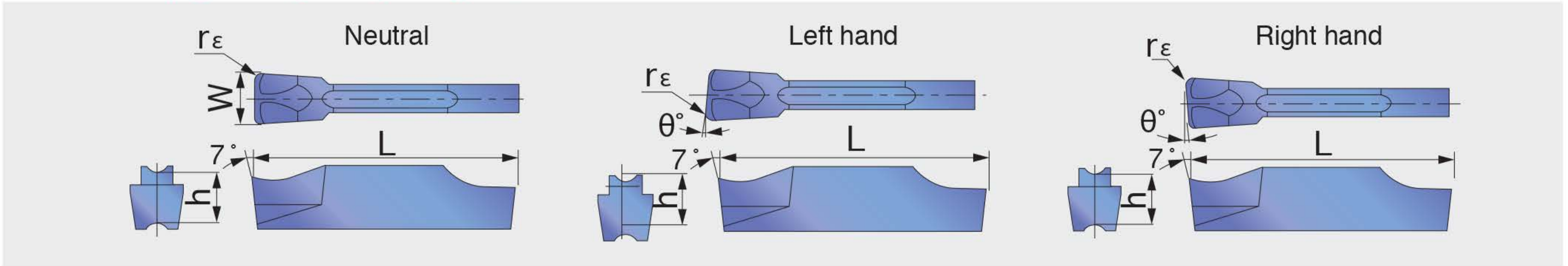

Designation	Insert seat size	W±0.05 (mm)	W±0.002 (in)	rε (in)	Grade		L (in)	h (in)	°θ
					AC22	TP222			
FSS2-020	2	2	0.079 (2.01)	0.008 (0.20)	●	●	0.787 (19.99)	0.197 (5.00)	0
FSS2-020-6R/L	2	2	0.079 (2.01)	0.008 (0.20)	●	●	0.787 (19.99)	0.197 (5.00)	6
FSS2-020-15R/L	2	2	0.079 (2.01)	0.008 (0.20)	●	●	0.787 (19.99)	0.197 (5.00)	15
FSS3-020	3	3	0.118 (3.00)	0.008 (0.20)	●	●	0.787 (19.99)	0.197 (5.00)	0
FSS3-020-6R/L	3	3	0.118 (3.00)	0.0008 (0.02)	●	●	0.787 (19.99)	0.197 (5.00)	6
FSS3-002-6R/L	3	3	0.118 (3.00)	0.008 (0.20)	●	●	0.780 (19.81)	0.197 (5.00)	6
FSS3-020-15R/L	3	3	0.118 (3.00)	0.008 (0.20)	●	●	0.787 (19.99)	0.197 (5.00)	15
FSS3-002-15R/L	3	3	0.118 (3.00)	0.0008 (0.02)	●	●	0.787 (19.99)	0.197 (5.00)	15
FSS4-030	4	4	0.157 (3.99)	0.012 (0.31)	●	●	0.787 (19.99)	0.197 (5.00)	0
FSS5-030	5	5	0.197 (5.00)	0.012 (0.31)	●	●	0.984 (24.99)	0.217 (5.51)	0
FSS6-030	6	6	0.236 (5.99)	0.012 (0.31)	●	●	0.984 (24.99)	0.217 (5.51)	0

● : Line up

FDE

External, grooving and turning

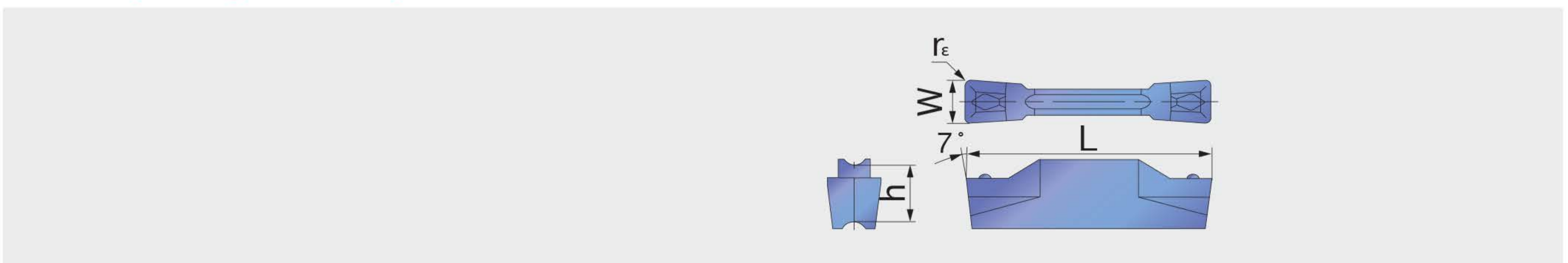

Designation	Insert seat size	W±0.05 (mm)	W±0.001 (in)	rε (in)	Grade		L (in)	h (in)
					AC22	TP222		
FDE3-040	3	3	0.118 (3.00)	0.016 (0.41)	●	●	0.787 (19.99)	0.197 (5.00)
FDE4-040	4	4	0.157 (3.99)	0.016 (0.41)	●	●	0.787 (19.99)	0.197 (5.00)

● : Line up

Multi-Functional Grooving tools

FDE

External, grooving and turning (for high-precision machining)

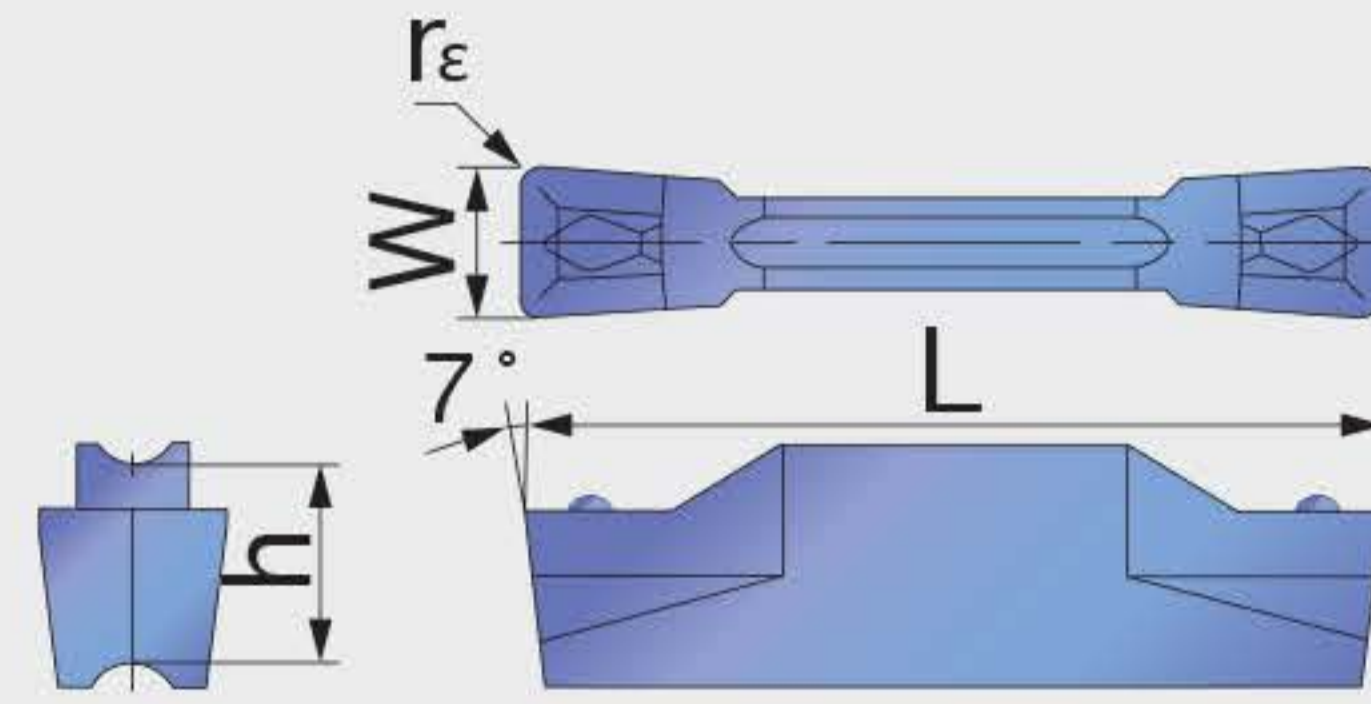

Designation	Insert seat size	W±0.02 (mm)	W±0.001 (in)	rε (in)	Grade		L (in)	h (in)
					AC22	TP222		
FDE265-015	3	2.65	0.104 (2.64)	0.006 (0.15)	●	●	0.787 (19.99)	0.197 (5.00)
FDE300-020	3	3	0.118 (3.00)	0.008 (0.20)	●	●	0.787 (19.99)	0.197 (5.00)
FDE300-040	3	3	0.118 (3.00)	0.016 (0.41)	●	●	0.787 (19.99)	0.197 (5.00)
FDE315-015	3	3.15	0.124 (3.15)	0.006 (0.15)	●	●	0.787 (19.99)	0.197 (5.00)
FDE400-040	4	4	0.157 (3.99)	0.016 (0.41)	●	●	0.787 (19.99)	0.197 (5.00)
FDE400-080	4	4	0.157 (3.99)	0.031 (0.79)	●	●	0.787 (19.99)	0.197 (5.00)
FDE415-015	4	4.15	0.163 (4.14)	0.006 (0.15)	●	●	0.787 (19.99)	0.197 (5.00)
FDE478-055	5	4.78	0.188 (4.78)	0.022 (0.56)	●	●	0.984 (24.99)	0.217 (5.51)
FDE500-040	5	5	0.197 (5.00)	0.016 (0.41)	●	●	0.984 (24.99)	0.217 (5.51)
FDE500-080	5	5	0.197 (5.00)	0.031 (0.79)	●	●	0.984 (24.99)	0.217 (5.51)
FDE515-015	5	5.15	0.203 (5.16)	0.006 (0.15)	●	●	0.984 (24.99)	0.217 (5.51)
FDE600-080	6	6	0.236 (5.99)	0.031 (0.79)	●	●	0.984 (24.99)	0.217 (5.51)
FDE600-120	6	6	0.236 (5.99)	0.047 (1.19)	●	●	0.984 (24.99)	0.217 (5.51)
FDE800-080	8	8	0.315 (8.00)	0.031 (0.79)	●	●	1.181 (30.00)	0.264 (6.71)
FDE800-120	8	8	0.315 (8.00)	0.047 (1.19)	●	●	1.181 (30.00)	0.264 (6.71)

● : Line up

FDET

External grooving (for high-precision machining)

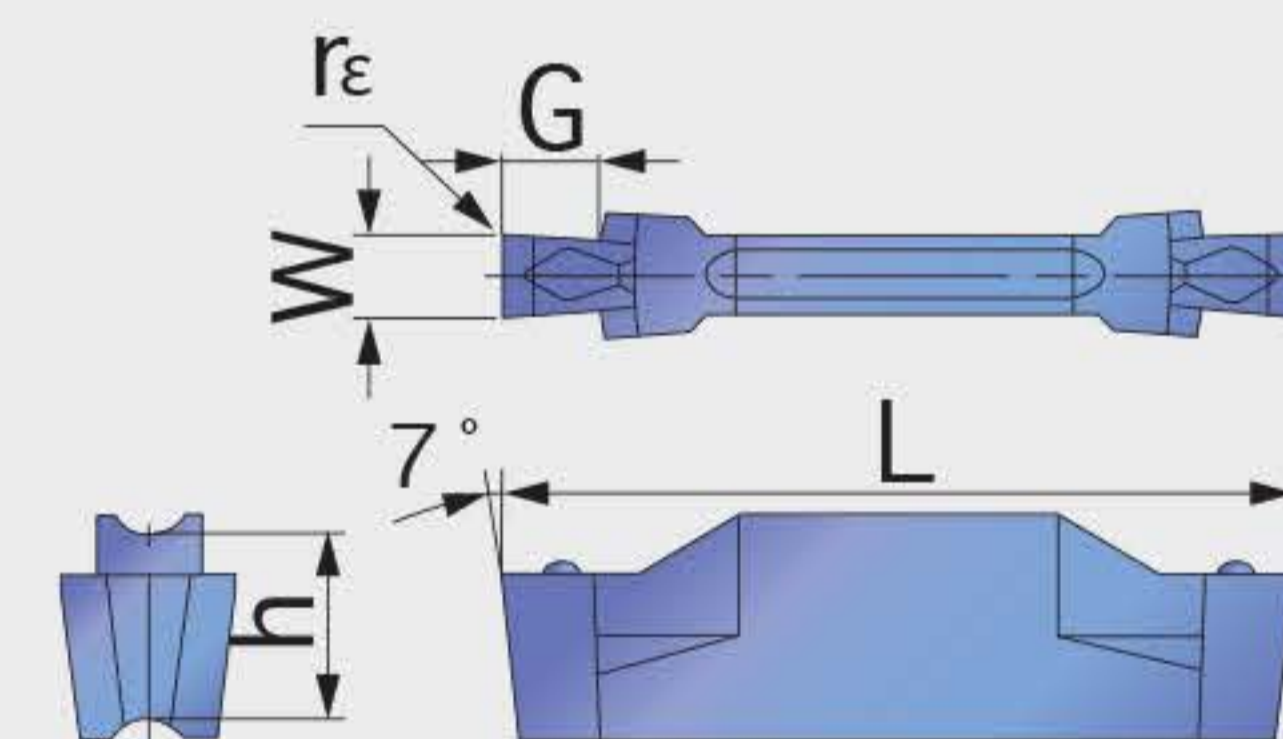

Designation	Insert seat size	W±0.02 (mm)	W±0.001 (in)	rε (in)	Grade		G (in)	L (in)	h (in)
					AC22	TP222			
FDET100-000	2	1	0.039 (0.99)	0	●	●	0.100 (2.54)	0.787 (19.99)	0.197 (5.00)
FDET130-000	2	1.3	0.051 (1.30)	0	●	●	0.100 (2.54)	0.787 (19.99)	0.197 (5.00)
FDET160-010	2	1.6	0.063 (1.60)	0.004 (0.10)	●	●	0.100 (2.54)	0.787 (19.99)	0.197 (5.00)
FDET185-010	2	1.85	0.073 (1.85)	0.004 (0.10)	●	●	0.140 (3.56)	0.787 (19.99)	0.197 (5.00)
FDET215-015	2	2.15	0.085 (2.16)	0.006 (0.15)	●	●	0.140 (3.56)	0.787 (19.99)	0.197 (5.00)

● : Line up

Multi-Functional Grooving tools

FDX

External, internal, face grooving and turning

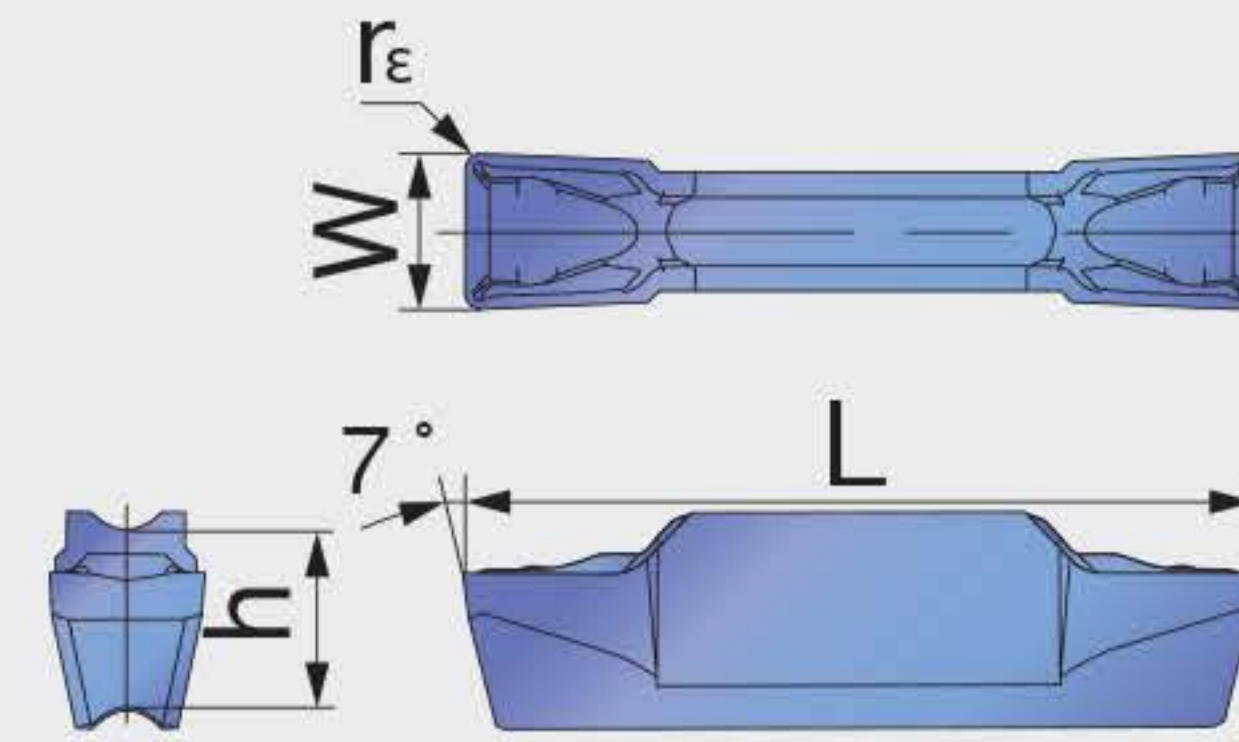

Designation	Insert seat size	W \pm 0.05 (mm)	W \pm 0.002 (in)	r ϵ (in)	Grade		L (in)	h (in)
					AC22	TP222		
FDX3-030	3	3	0.118 (3.00)	0.012 (0.31)	●	●	0.787 (19.99)	0.197 (5.00)
FDX4-040	4	4	0.157 (3.99)	0.016 (0.41)	●	●	0.787 (19.99)	0.197 (5.00)
FDX5-040	5	5	0.197 (5.00)	0.016 (0.41)	●	●	0.984 (24.99)	0.217 (5.51)
FDX6-080	6	6	0.236 (5.99)	0.031 (0.79)	●	●	0.984 (24.99)	0.217 (5.51)

● : Line up

FDIE

Internal grooving and turning (for high-precision machining)

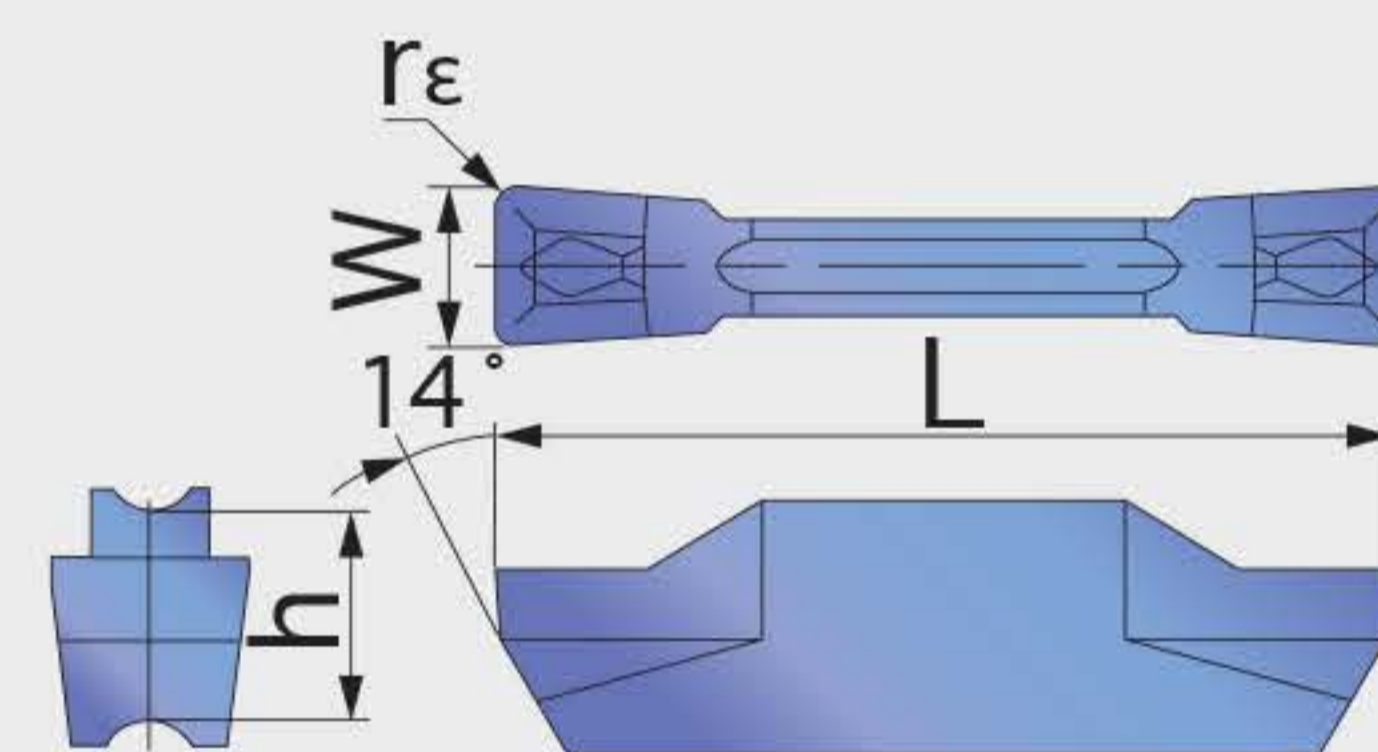

Designation	Insert seat size	W \pm 0.02 (mm)	W \pm 0.001 (in)	r ϵ (in)	Grade		L (in)	h (in)
					AC22	TP222		
FDIE300-040	3	3	0.118 (3.00)	0.016 (0.41)	●	●	0.787 (19.99)	0.197 (5.00)
FDIE400-040	4	4	0.157 (3.99)	0.016 (0.41)	●	●	0.787 (19.99)	0.197 (5.00)
FDIE400-080	4	4	0.157 (3.99)	0.031 (0.79)	●	●	0.787 (19.99)	0.197 (5.00)
FDIE500-040	5	5	0.197 (5.00)	0.016 (0.41)	●	●	0.984 (24.99)	0.217 (5.51)
FDIE500-080	5	5	0.197 (5.00)	0.031 (0.79)	●	●	0.984 (24.99)	0.217 (5.51)
FDIE600-080	6	6	0.236 (5.99)	0.031 (0.79)	●	●	0.984 (24.99)	0.217 (5.51)
FDIE600-120	6	6	0.236 (5.99)	0.047 (1.19)	●	●	0.984 (24.99)	0.217 (5.51)
FDIE800-080	8	8	0.315 (8.00)	0.031 (0.79)	●	●	1.181 (30.00)	0.264 (6.71)
FDIE800-120	8	8	0.315 (8.00)	0.047 (1.19)	●	●	1.181 (30.00)	0.264 (6.71)

● : Line up

Multi-Functional Grooving tools

FDIE

Internal grooving and turning

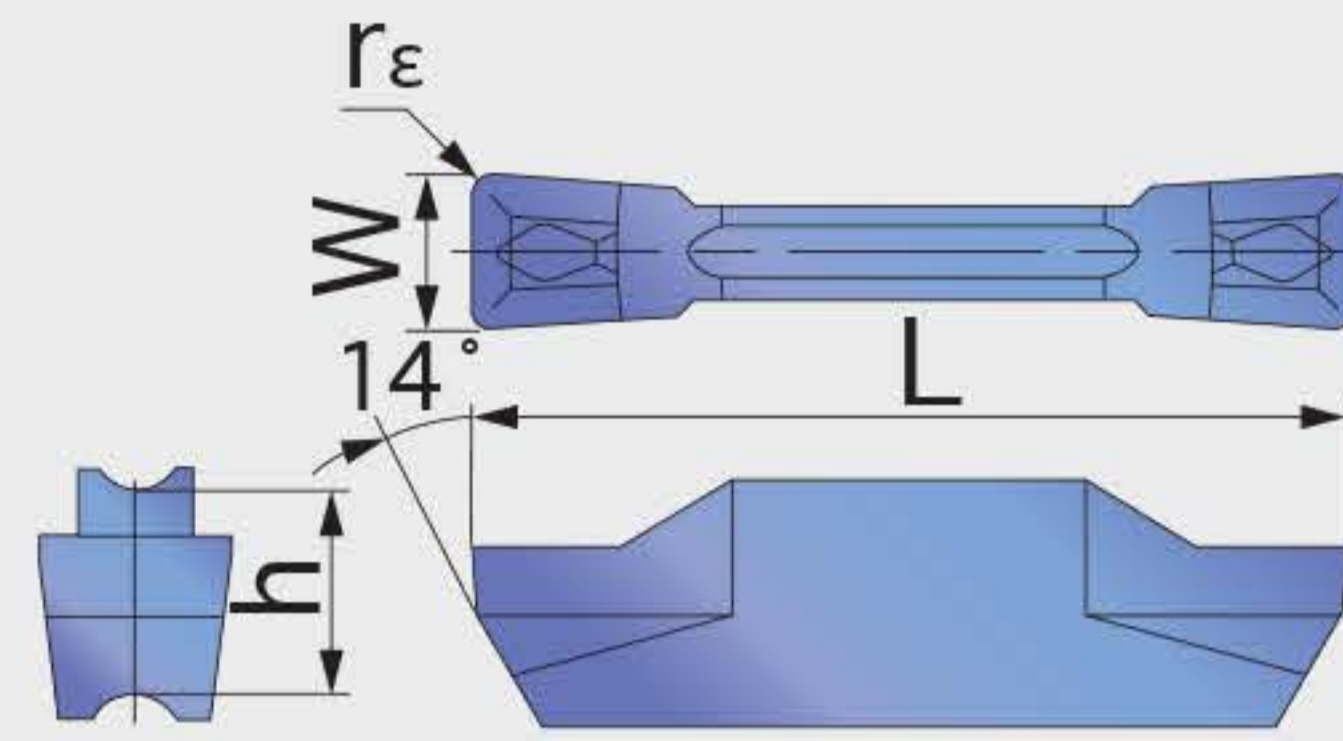

Designation	Insert seat size	W±0.05 (mm)	W±0.002 (in)	rε (in)	Grade		L (in)	h (in)
					AC22	TP222		
FDIE3-040	3	3	0.118 (3.00)	0.016 (0.41)	●	●	0.016 (0.41)	0.197 (5.00)
FDIE4-040	4	4	0.118 (3.00)	0.016 (0.41)	●	●	0.016 (0.41)	0.197 (5.00)

● : Line up

FDIM

Small diameter internal grooving

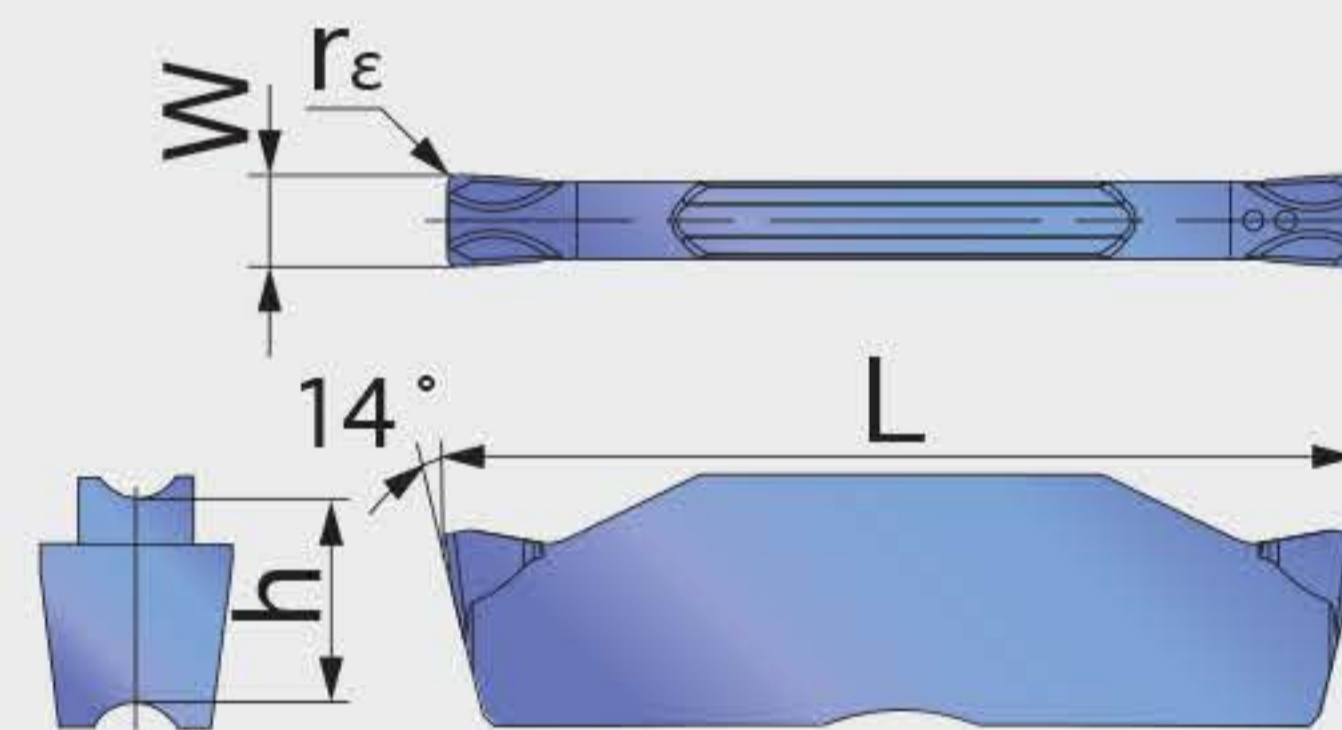

Designation	Insert seat size	W±0.05 (mm)	W±0.002 (in)	rε (in)	Grade		L (in)	h (in)
					AC22	TP222		
FDIM2-020	2	2	0.079 (2.01)	0.008 (0.20)	●	●	0.787 (19.99)	0.197 (5.00)

● : Line up

FDIS

Small diameter internal grooving

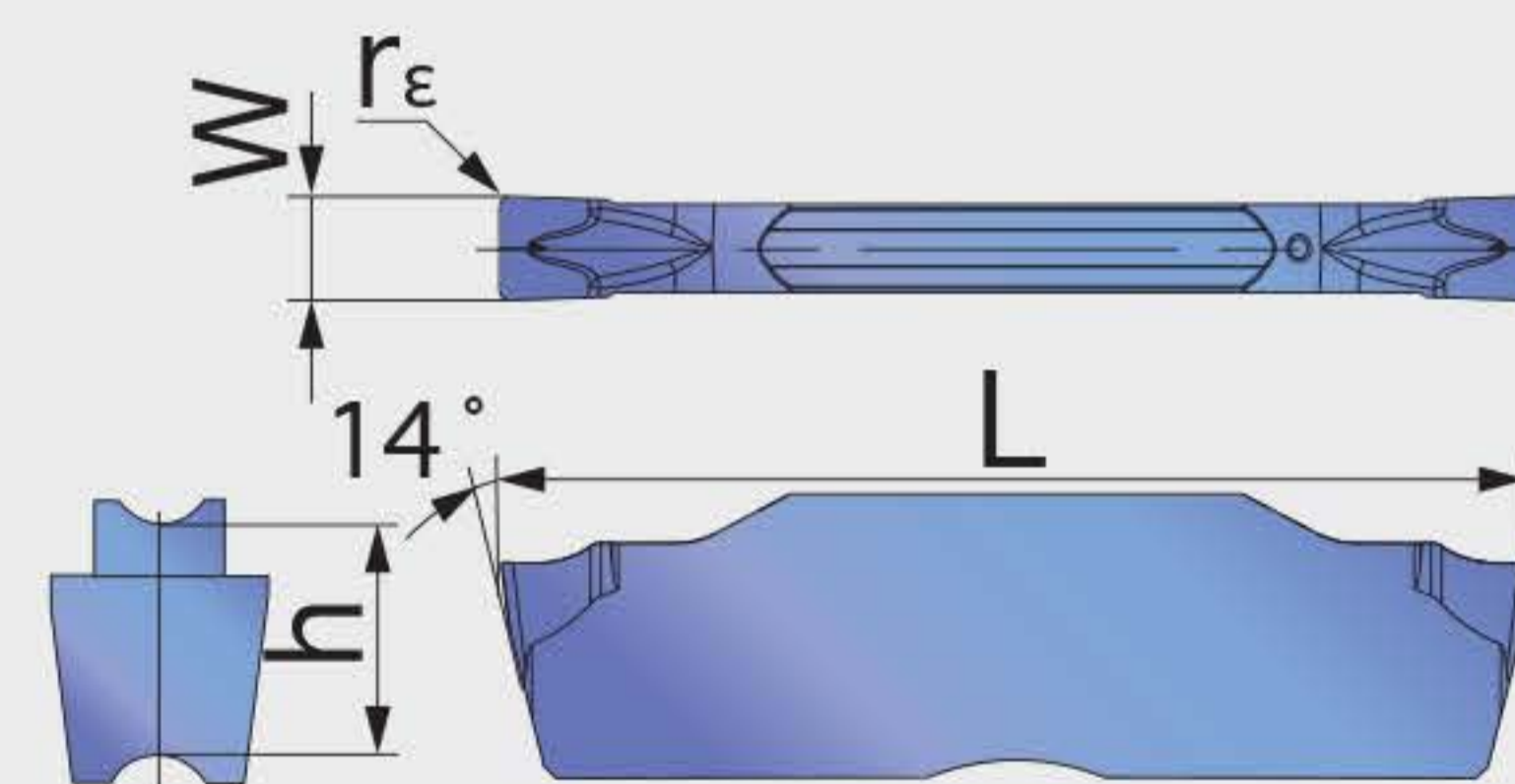

Designation	Insert seat size	W±0.05 (mm)	W±0.002 (in)	rε (in)	Grade		L (in)	h (in)
					AC22	TP222		
FDIS2-020	2	2	0.079 (2.01)	0.008 (0.20)	●	●	0.787 (19.99)	0.197 (5.00)

● : Line up

Multi-Functional Grooving tools

FDF

Face grooving and turning

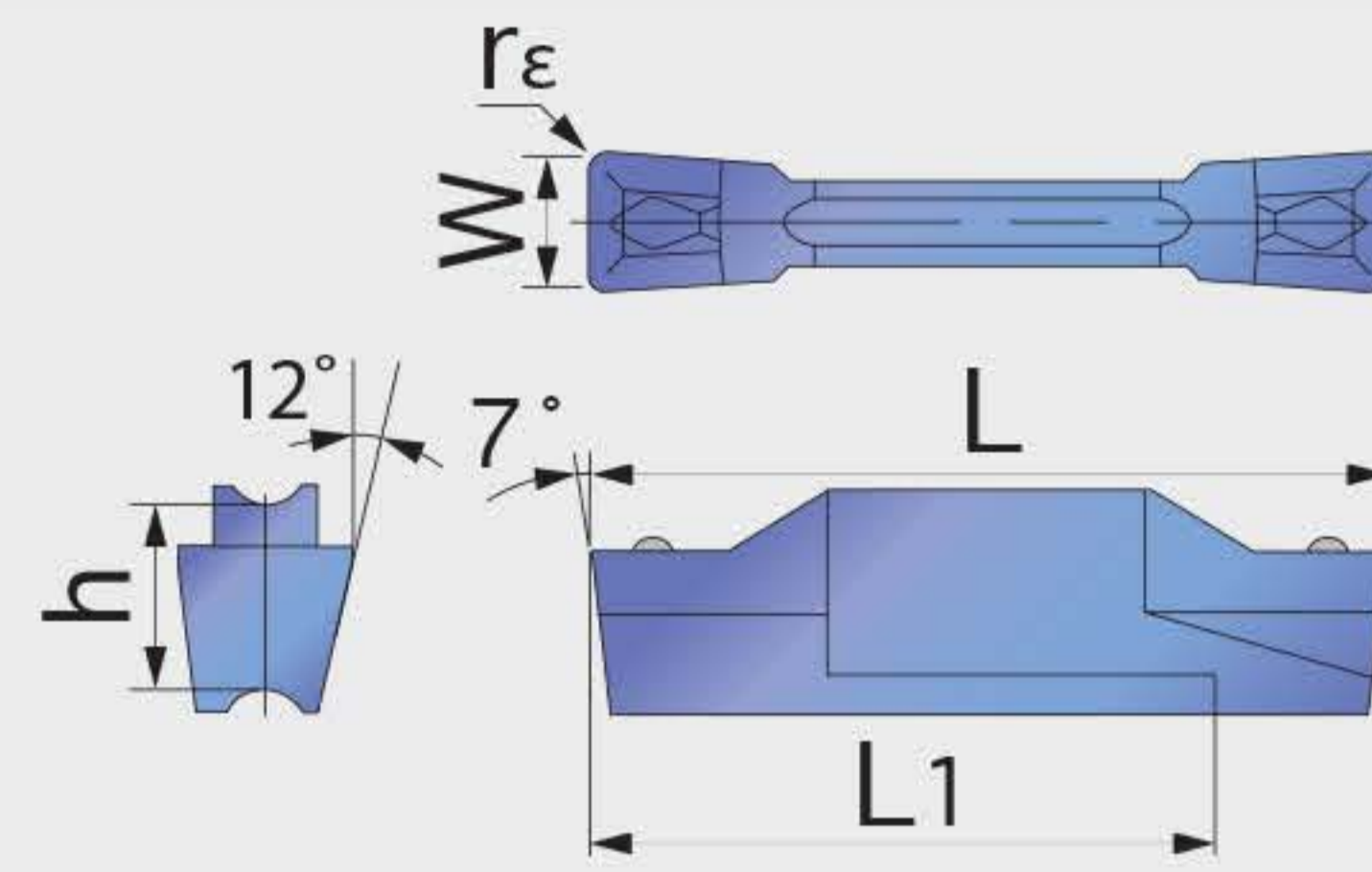

Designation	Insert seat size	W±0.05 (mm)	W±0.002 (in)	rε (in)	Grade		L (in)	h (in)	L ₁ (in)
					AC22	TP222			
FDF3-040-R/L	3	3	0.118 (3.00)	0.016 (0.41)	●	●	0.787 (19.99)	0.197 (5.00)	0.630 (16.00)
FDF4-040-R/L	4	4	0.157 (3.99)	0.016 (0.41)	●	●	0.787 (19.99)	0.197 (5.00)	0.630 (16.00)

● : Line up

FTR

Profiling and undercutting (for high precision machining)

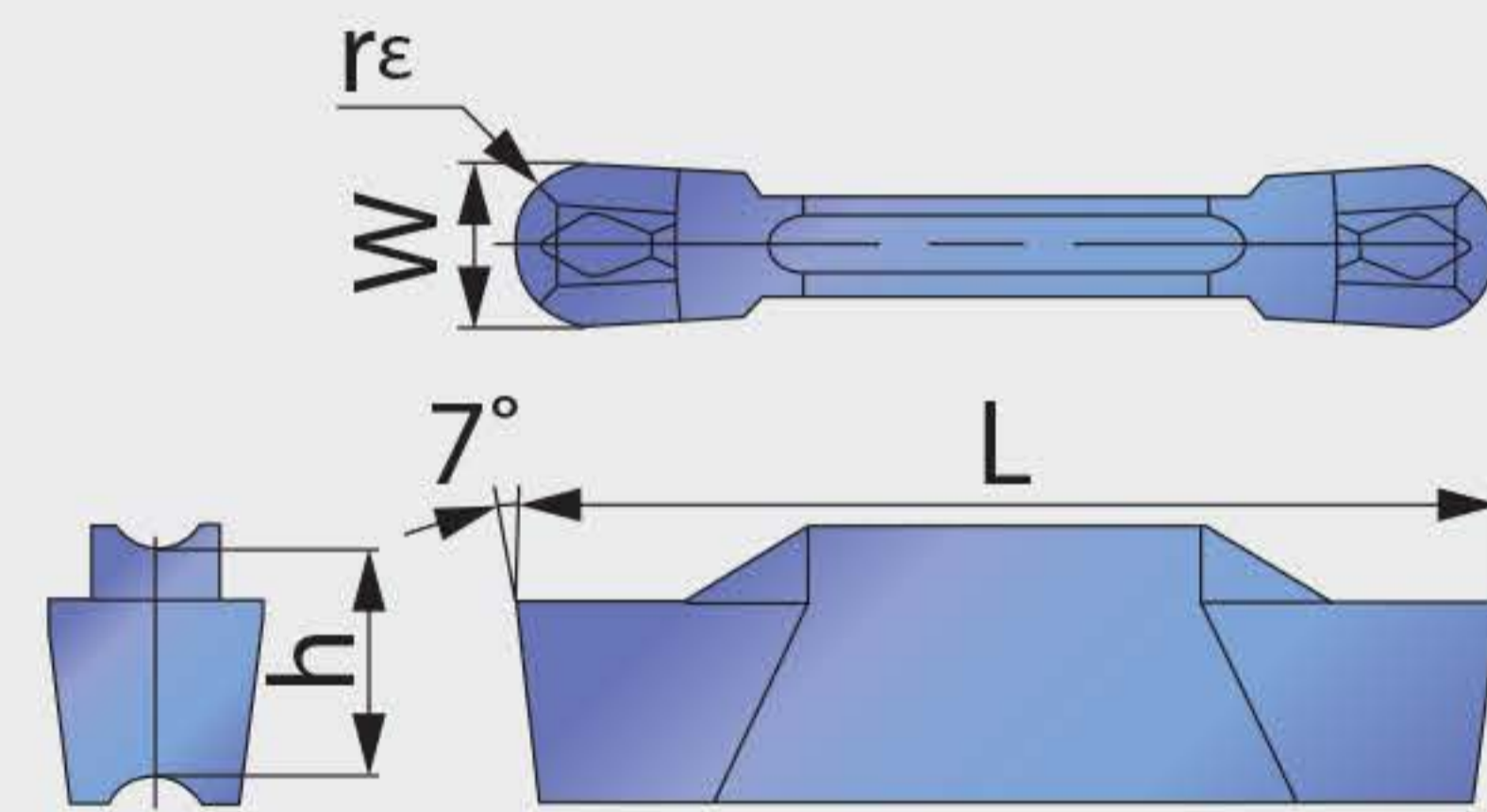

Designation	Insert seat size	W±0.05 (mm)	W±0.002 (in)	rε (in)	Grade		L (in)	h (in)
					TT9030	TT8020		
FTR300-150	3	3	0.118 (3.00)	0.059 (1.50)	●	●	0.787 (19.99)	0.197 (5.00)
FTR400-200	4	4	0.157 (3.99)	0.079 (2.01)	●	●	0.787 (19.99)	0.197 (5.00)
FTR478-239	5	4.78	0.188 (4.78)	0.094 (2.39)	●	●	0.984 (24.99)	0.217 (5.51)
FTR500-250	5	5	0.197 (5.00)	0.098 (2.49)	●	●	0.984 (24.99)	0.217 (5.51)
FTR600-300	6	6	0.236 (5.99)	0.118 (3.00)	●	●	0.984 (24.99)	0.217 (5.51)

● : Line up

FTR

Profiling and undercutting

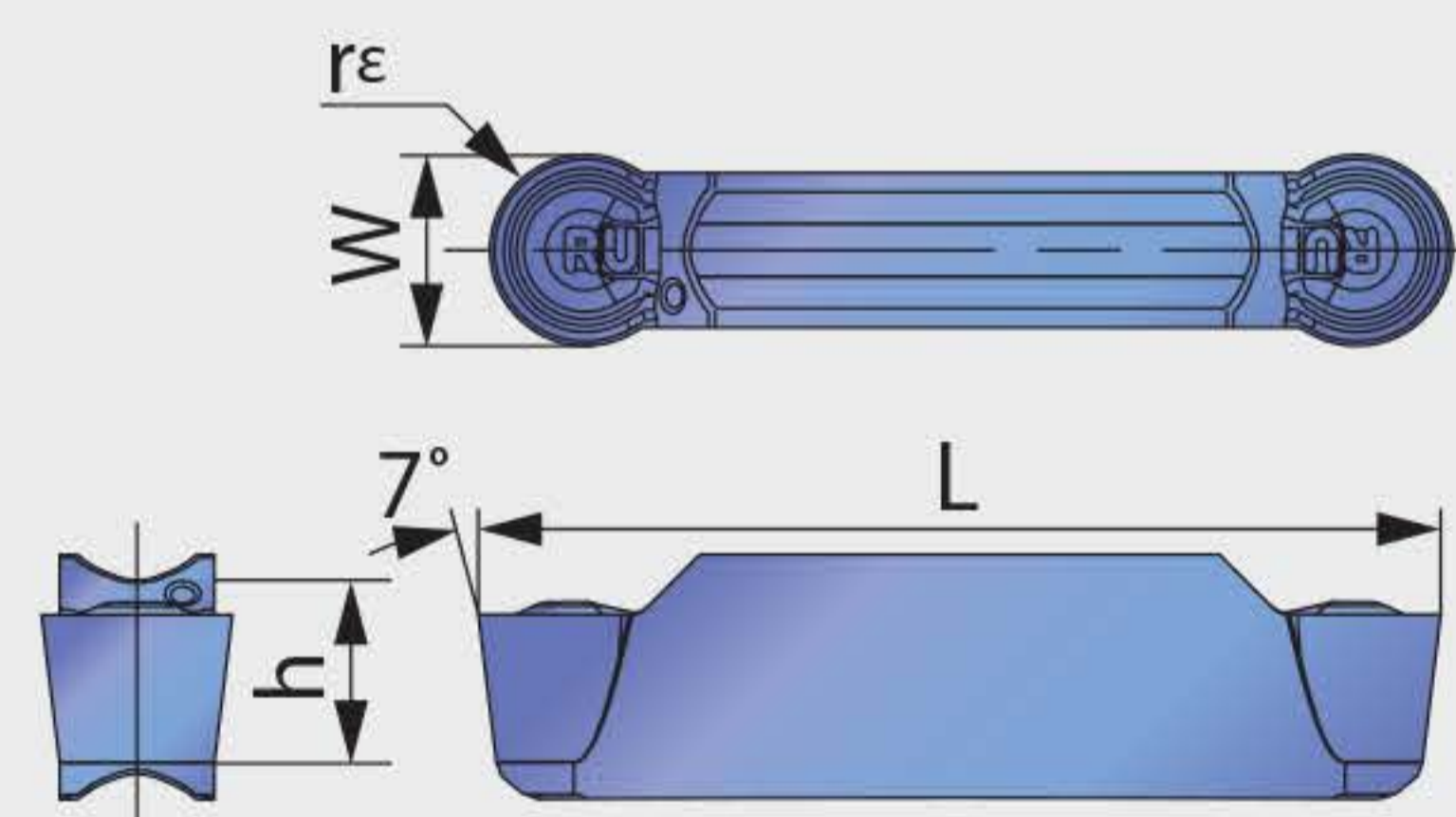

Designation	Insert seat size	W±0.05 (mm)	W±0.002 (in)	rε (in)	Grade		L (in)	h (in)
					TT9030	TT8020		
FTR3-150	3	3	0.118 (3.00)	0.059 (1.50)	●	●	0.787 (19.99)	0.197 (5.00)
FTR4-200	4	4	0.157 (3.99)	0.079 (2.01)	●	●	0.787 (19.99)	0.197 (5.00)
FTR5-250	5	4	0.197 (5.00)	0.098 (2.49)	●	●	0.984 (24.99)	0.217 (5.51)
FTR6-300	6	6	0.236 (5.99)	0.118 (3.00)	●	●	0.984 (24.99)	0.217 (5.51)
FTR8-400	8	8	0.315 (8.00)	0.157 (3.99)	●	●	1.181 (30.00)	0.264 (6.71)

Tool Holders



Multi-Functional Grooving tools

FHER/L

External toolholders for grooving, parting & turning

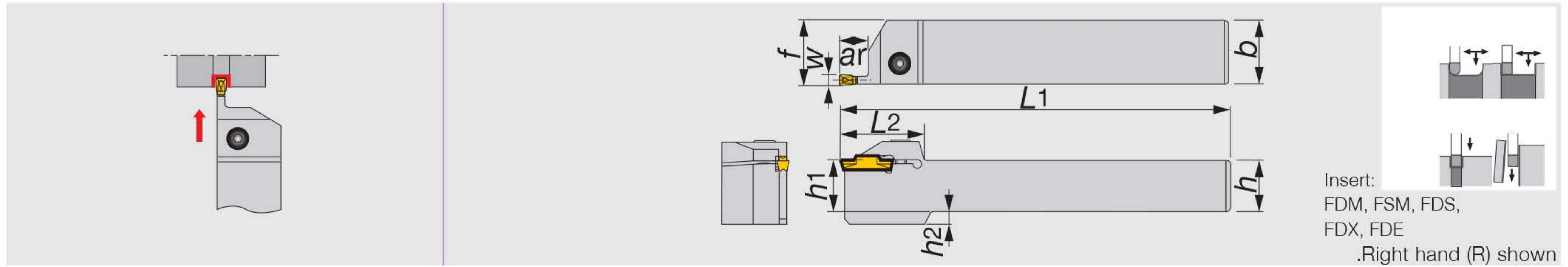

Description	W (in)	W (mm)	Seat size	ar	h	b	L ₁	L ₂	h ₁	f ⁽¹⁾	h ₂
FHER 12-2T08	0.079	2	2	0.315	0.750	0.750	5.000	1.299	0.750	0.754	-
FHER/L16-2T08	0.079	2	2	0.315	1.000	1.000	6.000	1.299	1.000	1.004	-
FHEL10-2T12	0.079	2	2	0.472	0.625	0.625	4.500	1.260	0.625	0.629	0.157
FHEL12-2T12	0.079	2	2	0.472	0.750	0.750	5.000	1.260	0.750	0.754	-
FHEL10-2T17	0.079	2	2	0.669	0.625	0.625	4.500	1.457	0.625	0.629	0.157
FHER/L12-2T17	0.079	2	2	0.669	0.750	0.750	5.000	1.457	0.750	0.754	-
FHER/L12-2T17-CH	0.079	2	2	0.669	0.750	0.750	5.000	1.772	0.750	0.754	-
FHER 16-2T17	0.079	2	2	0.669	1.000	1.000	6.000	1.457	1.000	1.004	-
FHER/L16-2T17-CH	0.079	2	2	0.669	1.000	1.000	6.000	1.772	1.000	1.004	-
FHER 10-3T09	0.118	3	3	0.354	0.625	0.625	4.500	1.260	0.625	0.637	0.157
FHER/L12-3T09	0.118	3	3	0.354	0.750	0.750	5.000	1.260	0.750	0.762	-
FHER 16-3T09	0.118	3	3	0.354	1.000	1.000	6.000	1.260	1.000	1.012	-
FHER/L12-3T12	0.118	3	3	0.472	0.750	0.750	5.000	1.260	0.750	0.763	-
FHER 16-3T12	0.118	3	3	0.472	1.000	1.000	6.000	1.260	1.000	1.012	-
FHER/L10-3T20	0.118	3	3	0.787	0.625	0.625	4.500	1.516	0.625	0.637	0.157
FHEL12-3T20	0.118	3	3	0.787	0.750	0.750	5.000	1.516	0.750	0.762	-
FHER/L16-3T20	0.118	3	3	0.787	1.000	1.000	6.000	1.516	1.000	1.012	0.157
FHER/L16-3T20-CH	0.118	3	3	0.787	1.000	1.000	6.000	1.890	1.000	1.012	0.157
FHER/L12-3T25-CH	0.118	3	3	0.984	0.750	0.750	5.000	2.008	0.750	0.762	0.157
FHER/L16-3T25	0.118	3	3	0.984	1.000	1.000	6.000	1.752	1.000	1.012	-
FHER/L16-3T25-CH	0.118	3	3	0.984	1.000	1.000	6.000	2.008	1.000	1.012	-
FHER/L16-4T10	0.157	4	4	0.394	1.000	1.000	6.000	1.260	1.000	1.020	-
FHER/L12-4T15	0.157	4	4	0.590	0.750	0.750	5.000	1.299	0.750	0.770	-
FHER/L16-4T15	0.157	4	4	0.590	1.000	1.000	6.000	1.299	1.000	1.020	-
FHER/L12-4T25	0.157	4	4	0.984	0.750	0.750	5.000	1.772	0.750	0.770	-
FHER/L16-4T25	0.157	4	4	0.984	1.000	1.000	6.000	1.772	1.000	1.020	-
FHER/L16-4T25-CH	0.157	4	4	0.984	1.000	1.000	6.000	2.165	1.000	1.020	-
FHER/L20-4T25	0.157	4	4	0.984	1.250	1.250	7.000	1.772	1.250	1.270	-
FHER 12-5T12	0.197	5	5	0.472	0.750	0.750	5.000	1.457	0.750	0.773	-
FHER 16-5T12	0.197	5	5	0.472	1.000	1.000	6.000	1.457	1.000	1.023	-
FHER/L16-5T20	0.197	5	5	0.787	1.000	1.000	6.000	1.457	1.000	1.024	-
FHER 16-5T32	0.197	5	5	1.260	1.000	1.000	6.000	2.205	1.000	1.004	-
FHER/L16-5T32-CH	0.197	5	5	1.260	1.000	1.000	6.000	2.323	1.000	1.024	-
FHER 20-5T32	0.197	5	5	1.260	1.250	1.250	7.000	2.205	1.250	1.271	-
FHER 16-6T12	0.236	6	6	0.472	1.000	1.000	6.000	1.457	1.000	1.023	3.5
FHER/L16-6T20	0.236	6	6	0.787	1.000	1.000	6.000	1.614	1.000	1.023	3.5
FHER 16-6T32	0.236	6	6	1.260	1.000	1.000	6.000	2.205	1.000	1.021	3.5
FHER/L16-6T32-CH	0.236	6	6	1.260	1.000	1.000	6.000	2.441	1.000	1.023	3.5
FHER/L20-6T32	0.236	6	6	1.260	1.250	1.250	7.000	2.205	1.250	1.271	-
FHER 16-8T16	0.315	8	8	0.630	1.000	1.000	6.000	1.850	1.000	1.043	3.5
FHER/L16-8T25	0.315	8	8	0.984	1.000	1.000	6.000	1.850	1.000	1.039	-
FHEL16-8T36	0.315	8	8	1.417	1.000	1.000	6.000	2.362	1.000	1.043	0.276
FHER/L20-8T36	0.315	8	8	1.417	1.250	1.250	7.000	2.362	1.250	1.293	-

• When depth is deeper than (insert length - 0.059"), 1 corner type is recommended.

(1) *f" value is calculated with groove width "W" shown in the table.

• -CH: High pressure coolant type

Multi-Functional Grooving tools

SPARE PARTS

Designation	Clamping screw	Wrench
FHER 12-2T08	CM5X0.8X20-A	P-4
FHER/L16-2T08	CM5X0.8X25-A	P-4
FHEL10-2T12	CM5X0.8X16-A	P-4
FHEL12-2T12	CM5X0.8X20-A	P-4
FHEL10-2T17	CM5X0.8X16-A	P-4
FHER/L12-2T17	CM5X0.8X20-A	P-4
FHER 16-2T17	CM5X0.8X25-A	P-4
FHER 10-3T09	CM5X0.8X16-A	P-4
FHER/L12-3T09	CM5X0.8X20-A	P-4
FHER/L12-3T12	CM5X0.8X25-A	P-4
FHER 16-3T12	CM5X0.8X20-A	P-4
FHER/L10-3T20	CM5X0.8X25-A	P-4
FHEL 12-3T20	CM5X0.8X16-A	P-4
FHER/L16-3T20	CM5X0.8X20-A	P-4
FHER/L16-3T25	CM5X0.8X25-A	P-4
FHER/L16-4T10	CM6X1X25-A	P-5

SPARE PARTS

Designation	Clamping screw	Wrench
FHER/L12-4T15	CM6X1X20-A	P-5
FHER/L16-4T15	CM6X1X25-A	P-5
FHER/L12-4T25	CM6X1X20-A	P-5
FHER/L16-4T25	CM6X1X25-A	P-5
FHER/L20-4T25	CM6X1X25-A	P-5
FHER 12-5T12	CM6X1X20-A	P-5
FHER 16-5T20	CM6X1X25-A	P-5
FHER/L16-5T32	CM6X1X25-A	P-5
FHER 20-5T32	CM8X1.25X20-A	P-6
FHER 16-6T12	CM8X1.25X25-A	P-6
FHER/L16-6T20	CM8X1.25X25-A	P-6
FHER 16-6T32	CM8X1.25X25-A	P-6
FHER 20-6T32	CM8X1.25X25-A	P-6
FHER 16-8T16	CM8X1.25X25-A	P-6
FHER/L16-8T25	CM8X1.25X25-A	P-6
FHEL 16-8T36	CM8X1.25X25-A	P-6
FHER/L20-8T36	CM8X1.25X25-A	P-6

FHEVR/L

External grooving & parting toolholders for swiss lathes

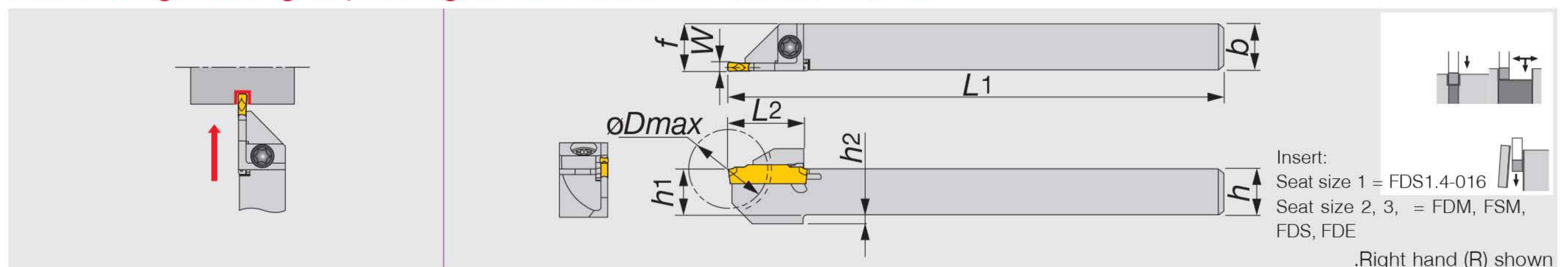

Description	W	Seat size	øD _{max}	h	b	L ₁	L ₂	h ₁	f ⁽¹⁾	h ₂
FHEVR/L08-2T12	0.079	2	0.945	0.500	0.500	4.750	0.748	0.500	0.505	0.051
FHEVR/L08-3T12	0.118	3	0.945	0.500	0.500	4.750	0.748	0.500	0.512	0.051
FHEVR/L10-2T16	0.079	2	1.260	0.625	0.625	4.750	0.945	0.625	0.630	-
FHEVR/L10-3T16	0.118	3	1.260	0.625	0.625	4.750	0.945	0.625	0.637	-

(1) "f" value is calculated with groove width "W" shown in the table. • øD_{max}: Max. parting off dia.

SPARE PARTS

Designation	Clamping screw	Wrench
...FHEVR/L	CSHB-4-A	T-15F

Multi-Functional Grooving tools

FHEFR/L

Toolholders for External / Face grooving & turning

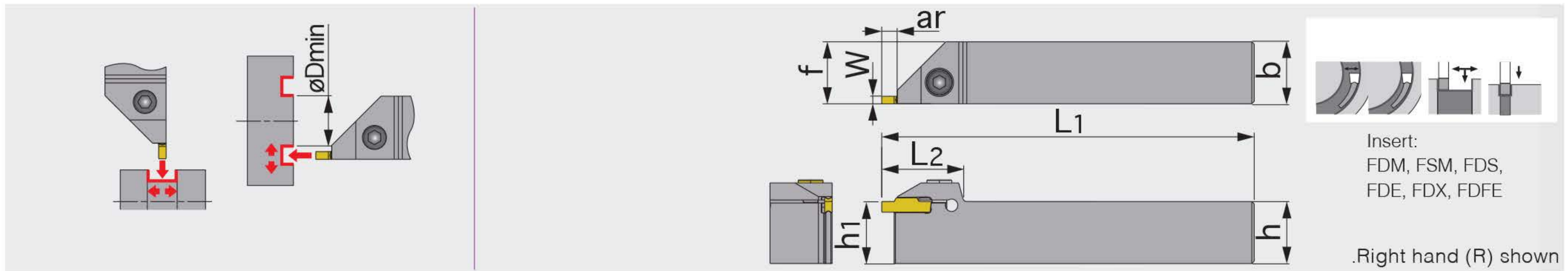

Description	W (in)	W (mm)	Seat size	ar	h ₁	b	h	L ₁	f	L ₂
FHEFR/L12-4T04	0.079, 0.118, 0.157	4	2, 3, 4	0.157 (3.99)	0.750 (19.05)	0.750 (19.05)	0.750 (19.05)	5.000 (127.00)	0.770 (19.56)	1.299 (33.00)
FHEFR/L16-4T04	0.079, 0.118, 0.157	4	2, 3, 4	0.157 (3.99)	1.000 (25.40)	1.000 (25.40)	1.000 (25.40)	6.000 (152.40)	1.020 (25.91)	1.299 (33.00)
FHEFR/L12-6T04	0.197, 0.236	6	5, 6	0.157 (3.99)	0.750 (19.05)	0.750 (19.05)	0.750 (19.05)	5.000 (127.00)	0.773 (19.63)	1.457 (37.01)
FHEFR/L16-6T04	0.197, 0.236	6	5, 6	0.157 (3.99)	1.000 (25.40)	1.000 (25.40)	1.000 (25.40)	6.000 (152.40)	1.023 (25.98)	1.457 (37.01)

(1) "f" value is calculated with groove width "W" shown in the table.

SPARE PARTS

Designation	Clamping screw	Wrench
FHEFR/L12-4T04	CM6X1X20-A	P-5
FHEFR/L16-4T04	CM6X1X25-A	P-5
FHEFR/L12-6T04	CM6X1X20-A	P-5
FHEFR/L16-6T04	CM6X1X25-A	P-5

Insert	Groove width W (in)	.Min. dia for face grooving øDmin (in)
FDM / FDS	0.078	11.614
FDM / FDS	0.118	2.126
FDM / FDS	0.157	1.339
FDM / FDS	0.196	1.929
FDM / FDS	0.236	1.811
FDE	0.118	1.732
FDE	0.157	1.654
FDE	0.196	1.969
FDE	0.236	1.890

Insert	Groove width W (in)	.Min. dia for face grooving øDmin (in)
FDX	0.118	0.709
FDX	0.157	0.709
FDX	0.196	0.787
FDX	0.236	0.709
FDF	0.118	0.709
FDF	0.157	0.787

Multi-Functional Grooving tools

FCER/L

Blades for external grooving & parting & turning

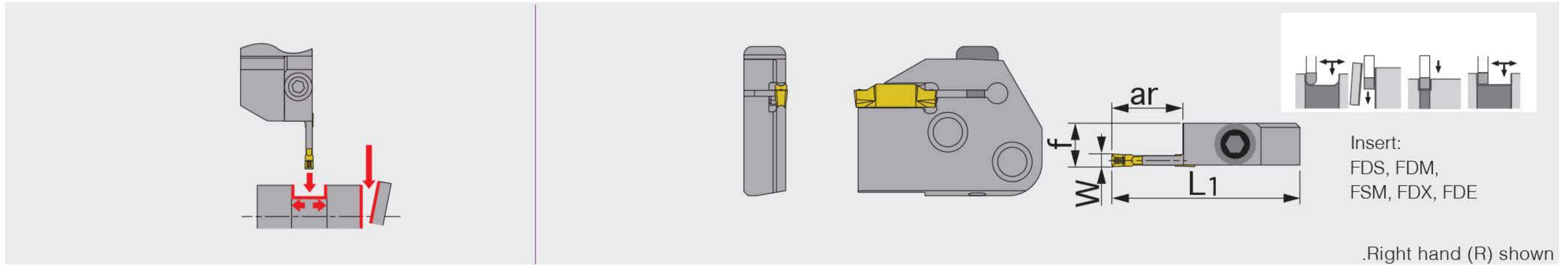

Description	W (in)	W (mm)	Seat size	ar	L ₁	f	Shank
FCER/L-3T16	0.118	3	3	0.630 (16.00)	1.772 (45.01)	0.409 (10.39)	...FHFL/R...,FHCR/L
FCER/L-4T16	0.157	4	4	0.630 (16.00)	1.772 (45.01)	0.413 (10.49)	...FHFL/R...,FHCR/L
FCER-5T20	0.197	5	5	0.787 (19.99)	1.949 (49.51)	0.413 (10.49)	...FHFL/R...,FHCR/L

SPARE PARTS

Designation	Clamping screw	Wrench
...CAER/L	BHM6-20-A	P-4

FBE

Blades for external deep grooving & parting

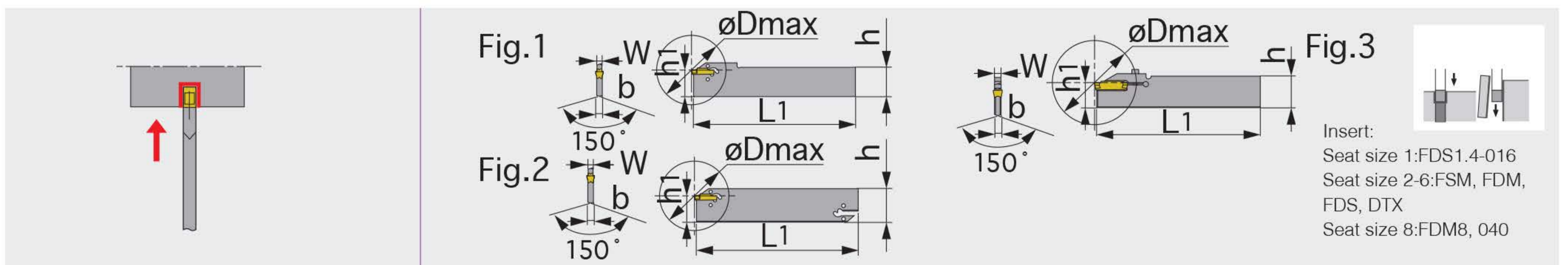

Description	W (in)	W (mm)	Seat size	øD _{max}	h ₁	b	h	L ₁	Fig
FBE26-1.4S	0.055	1.4	1	1.024 (26.01)	0.843 (21.41)	0.039 (0.99)	1.024 (26.01)	5.906 (150.01)	1
FBE32-1.4D	0.055	1.4	1	1.024 (26.01)	0.976 (24.79)	0.039 (0.99)	1.260 (32.00)	5.906 (150.01)	2
FBE26-2S	0.079	2	2	1.575 (40.01)	0.843 (21.41)	0.071 (1.80)	1.024 (26.01)	5.906 (150.01)	1
FBE32-2D	0.079	2	2	1.969 (50.01)	0.976 (24.79)	0.071 (1.80)	1.260 (32.00)	5.906 (150.01)	2
FBE26-3S	0.118	3	3	1.969 (50.01)	0.843 (21.41)	0.094 (2.39)	1.024 (26.01)	5.906 (150.01)	1
FBE32-3D	0.118	3	3	3.937 (100.00)	0.976 (24.79)	0.094 (2.39)	1.260 (32.00)	5.906 (150.01)	2
FBE26-4S	0.157	4	4	3.150 (80.01)	0.844 (21.44)	0.126 (3.20)	1.024 (26.01)	5.906 (150.01)	1
FBE32-4D	0.157	4	4	3.937 (100.00)	0.980 (24.89)	0.126 (3.20)	1.260 (32.00)	5.906 (150.01)	2
FBE45-4D	0.157	4	4	4.724 (119.99)	1.500 (38.10)	0.126 (3.20)	1.772 (45.01)	5.906 (150.01)	2
FBE32-5D	0.197	5	5	4.724 (119.99)	0.980 (24.89)	0.156 (3.96)	1.260 (32.00)	5.906 (150.01)	2
FBE32-6D	0.236	6	6	4.724 (119.99)	0.980 (24.89)	0.203 (5.16)	1.260 (32.00)	5.906 (150.01)	2
FBE32-8S-CL	0.315	8	8	3.150 (80.01)	0.980 (24.89)	0.244 (6.20)	1.260 (32.00)	5.906 (150.01)	3

- When depth is deeper than (insert length - 0.059"), 1 corner type is recommended. • Wrench (CRW**) should be ordered separately.
- Max groove depth is 1.122".
- øD_{max}: Max. parting off dia.

SPARE PARTS

Designation	Clamping screw	Wrench
FBE**-1.4*	-	CRW23
FBE**-2/3/4/5/6	-	CRW33
FBE32-8S-CL	CM4X0.7X20-M0-A	P-3

Multi-Functional Grooving tools

FHFR/L

Shank of perpendicular toolholders for FCER/L & FCFR/L blades

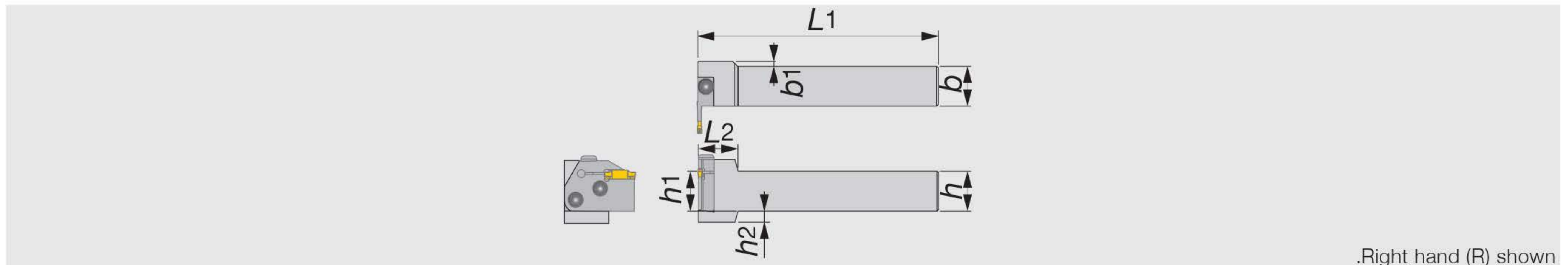

Description	h	b	L ₁	L ₂	h ₁	h ₂	b ₁	Blade
FHFR/L16-U	1.000	1.000	6.000	0.980	1.000	0.280	0.118	FCER/R...,FCER/L...

SPARE PARTS

Designation	Clamping screw	Wrench
FHFR/L...	CSHB-6-A	P-4

Combination of blade and toolholder

Toolholders	Blade			
	FCER...	FCERL...	FCFR...	FCFL...
FHFR...		●	●	
FHFL...	●			●

● : Corresponding

Multi-Functional Grooving tools

FHCR/L

Shank of toolholders for FCER/L & FCFR/L blades

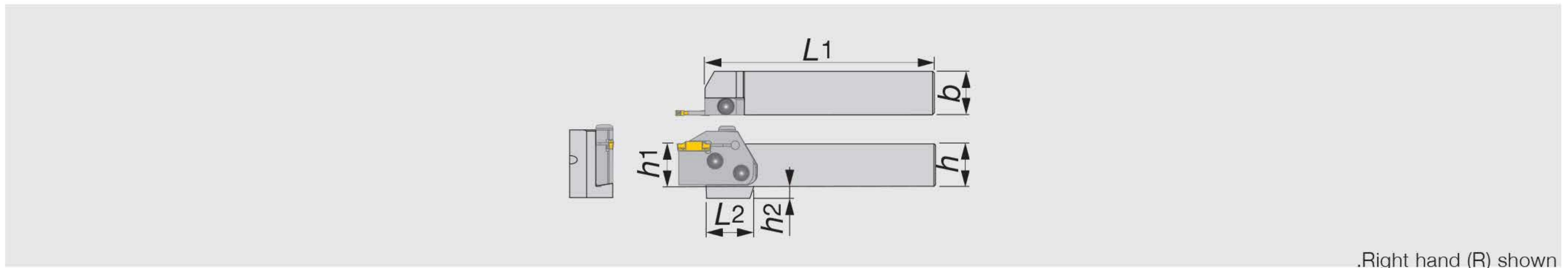

.Right hand (R) shown

Description	h	b	L ₁	L ₂	h ₁	h ₂	Blade*
FHCR 12-U	0.750	0.750	5.331	1.378	0.750	0.502	FCER/L...,FCFL/R...
FHCR/L16-U	1.000	1.000	5.331	1.102	1.000	0.276	FCER/L...,FCFL/R...

* Blade sold separately.

SPARE PARTS		
Designation	Clamping screw	Wrench
FHCR/L...	CSHB-6-A	P-4

Combination of blade and toolholder

Toolholders	Blade			
	FCER...	FCEL...	FCFR...	FCFL...
FHCR...	●			●
FHCL...		●	●	

● : Corresponding

Multi-Functional Grooving tools

FHIR/L

Boring bars for small internal grooving & turning

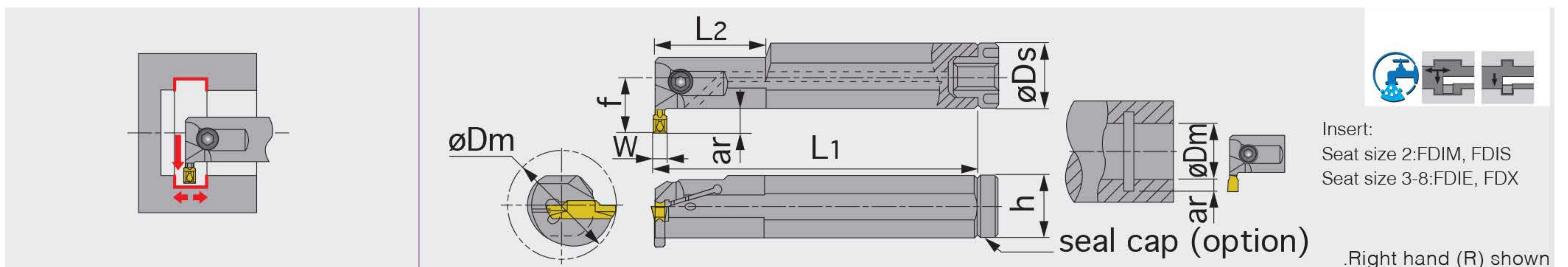

Description	W	øD _m	Seat size	ar	øD _s	f	L ₁	L ₂	h	Insert
FHIR 12-3T06-D16	0.118 (3.00)	0.984 (24.99)	3	0.236 (5.99)	0.750 (19.05)	0.609 (15.47)	6.500 (165.10)	1.575 (40.01)	0.661 (16.79)	FDIM..., FDIS...
FHIR 16-3T08-D20	0.118 (3.00)	1.260 (32.00)	3	0.315 (8.00)	1.000 (25.40)	0.846 (21.49)	8.000 (203.20)	1.614 (41.00)	0.906 (23.01)	FDIE..., FDX...
FHIR 20-3T10-D25	0.118 (3.00)	1.575 (40.01)	3	0.394 (10.01)	1.250 (31.75)	1.063 (27.00)	10.000 (254.00)	2.402 (61.01)	1.102 (27.99)	FDIE..., FDX...
FHIR 20-4T10-D25	0.157 (3.99)	1.575 (40.01)	4	0.394 (10.01)	1.250 (31.75)	1.063 (27.00)	10.000 (254.00)	2.402 (61.01)	1.102 (27.99)	FDIE..., FDX...
FHIR 20-5T10-D25	0.197 (5.00)	1.575 (40.01)	5	0.394 (10.01)	1.250 (31.75)	1.063 (27.00)	10.000 (254.00)	2.402 (61.01)	1.102 (27.99)	FDIE..., FDX...
FHIR 20-6T10-D25	0.236 (5.99)	1.563 (39.70)	6	0.394 (10.01)	1.250 (31.75)	1.063 (27.00)	10.000 (254.00)	2.362 (60.00)	1.102 (27.99)	FDIE..., FDX...

(1) "L1" value is calculated with groove width "W" shown in the table.

Inch SPARE PARTS



Designation	Clamping screw	Wrench	Seal cap	Thread type for connection
FHIR 12-3T06-D16	CM5x0.8x12-A	P-4	CA-20	M6
FHIR 16-3T08-D20	CM5x0.8x16-A	P-4	CA-25	R1/8"
FHIR 20-3T10-D25	CM5x0.8x16-A	P-4	CA-32	R1/8"
FHIR 20-4T10-D25	CM5x0.8x16-A	P-4	CA-32	R1/8"
FHIR 20-5T10-D25	CM6x1x20-A	P-5	CA-32	R1/8"
FHIR 20-6T04-D20	CM6x1x20-A	P-5	CA-32	R1/8"

Multi-Functional Grooving tools

FCFR/L

Blades for face grooving & turning

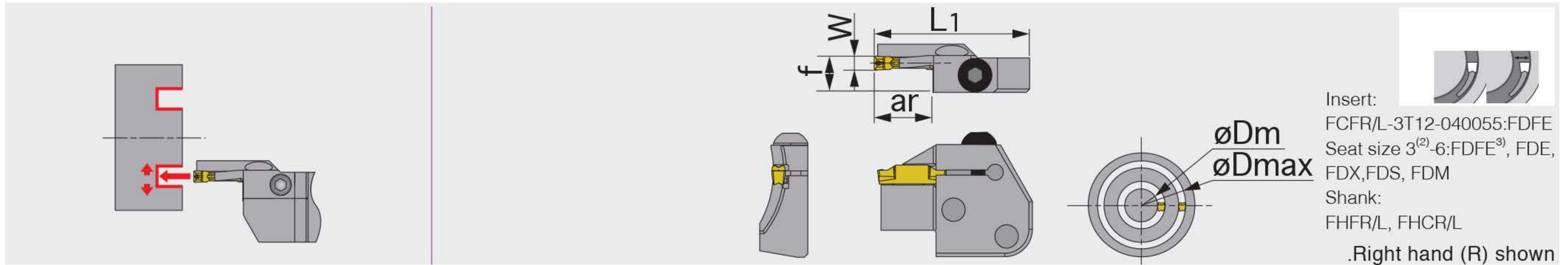

Insert:
FCFR/L-3T12-040055:FDFE
Seat size 3⁽²⁾-6:FDFE⁽³⁾, FDE,
FDX,FDS, FDM
Shank:
FHFR/L, FHCR/L
.Right hand (R) shown

Description	W	øD _m	øD _{max}	Seat size	ar	L ₁	f ⁽¹⁾
FCFR/L-3T12-040055	0.118 (3.00)	1.575 (40.01)	2.165 (54.99)	3	0.472 (11.99)	1.772 (45.01)	0.409 (10.39)
FCFR/L-3T12-055075	0.118 (3.00)	2.165 (54.99)	2.953 (75.01)	3	0.472 (11.99)	1.772 (45.01)	0.409 (10.39)
FCFR/L-3T12-075100	0.118 (3.00)	2.953 (75.01)	3.937 (100.00)	3	0.472 (11.99)	1.772 (45.01)	0.409 (10.39)
FCFR/L-3T12-100140	0.118 (3.00)	3.937 (100.00)	5.512 (140.01)	3	0.472 (11.99)	1.772 (45.01)	0.409 (10.39)
FCFR/L-3T12-140200	0.118 (3.00)	5.512 (140.01)	7.874 (200.00)	3	0.472 (11.99)	1.772 (45.01)	0.409 (10.39)
FCFR/L-4T16-050070	0.157 (3.99)	1.969 (50.01)	2.756 (70.00)	4	0.630 (16.00)	1.772 (45.01)	0.413 (10.49)
FCFR/L-4T16-070100	0.157 (3.99)	2.756 (70.00)	3.937 (100.00)	4	0.630 (16.00)	1.772 (45.01)	0.413 (10.49)
FCFR/L-4T16-100150	0.157 (3.99)	3.937 (100.00)	5.906 (150.01)	4	0.630 (16.00)	1.772 (45.01)	0.413 (10.49)
FCFL-4T16-150250	0.157 (3.99)	5.906 (150.01)	9.843 (250.01)	4	0.630 (16.00)	1.772 (45.01)	0.413 (10.49)
FCFR-5T20-055080	0.197 (5.00)	2.165 (54.99)	3.150 (80.01)	5	0.787 (19.99)	1.949 (49.51)	0.413 (10.49)
FCFL-5T20-080120	0.197 (5.00)	3.150 (80.01)	4.724 (119.99)	5	0.787 (19.99)	1.949 (49.51)	0.413 (10.49)
FCFR-6T25-090150	0.236 (5.99)	3.543 (89.99)	5.906 (150.01)	6	0.984 (24.99)	2.185 (55.50)	0.413 (10.49)

• When depth is deeper than (insert length - 0.059"), 1 corner type is recommended.

(1) "f" value is calculated with groove width "W" shown in the table.

(2) Not applicable for FCFR/L-3T12-040055

(3) Seat sizes of DTF are Only 3 and 4

SPARE PARTS

Designation	Clamping screw	Wrench
...CAFR/L	BHM6-20-A	P-4

Min. diameter øDm of FDE, FDS and FDM insert

Insert	øDm	Note
FDE 3 / FDS 3 / FDM 3	ø1.733	When diameter is smaller than øDm, FDFE or FDX type insert is recommended.
FDE 4 / FDS 4 / FDM 4	ø1.654	
FDE 5 / FDS 5 / FDM 5	ø1.969	
FDE 6 / FDS 6 / FDM 6	ø1.890	

Multi-Functional Grooving tools

FHIFR/L

Toolholders for face / internal face grooving & turning

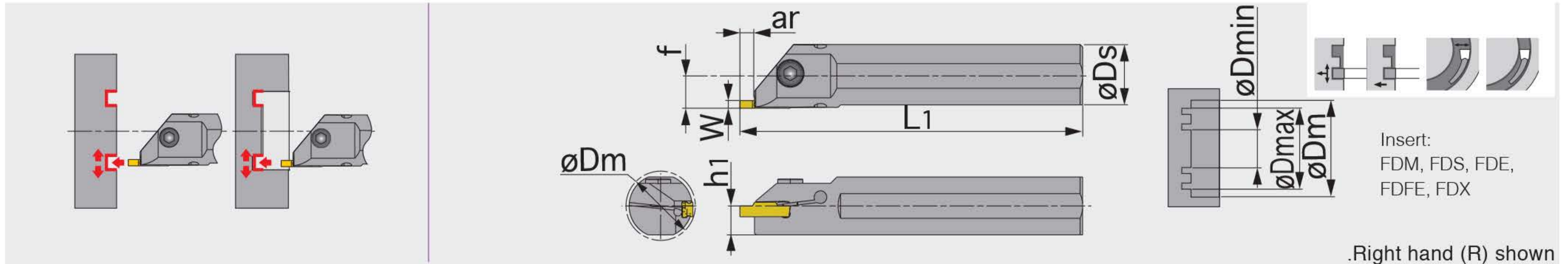

.Right hand (R) shown

Description	W	Seat size	ar	øD _s	h ₁	L ₁ ⁽¹⁾	f
FHIFR/L16-4T05-D17	0.118, 0.157	4,3	0.197 (5.00)	1.000 (25.40)	0.461 (11.71)	8.000 (203.20)	0.531 (13.49)
FHIFR/L20-4T05-D22	0.118, 0.157	4,3	0.197 (5.00)	1.250 (31.75)	0.585 (14.86)	10.000 (254.00)	0.492 (12.50)
FHIFR/L16-5T05-D17	0.197, 0.236	6,5	0.197 (5.00)	1.000 (25.40)	0.461 (11.71)	8.000 (203.20)	0.676 (17.17)
FHIFR/L20-5T05-D22	0.197, 0.236	6,5	0.197 (5.00)	1.250 (31.75)	0.585 (14.86)	10.000 (254.00)	0.637 (16.18)

(1) "f" value is calculated with groove width "W" shown in the table.**

Inch SPARE PARTS



Designation	Clamping screw	Wrench
FHIFR/L16-4T05-D17	CM6X1X16-A	P-5
FHIFR/L20-4T05-D22	CM6X1X20-A	P-5
FHIFR/L16-5T05-D17	CM6X1X16-A	P-5
FHIFR/L20-5T05-D22	CM6X1X20-A	P-5

Insert seat size	Min. bore dia. øDm		Insert seat size	øDmin			øDmax
	øDs = 0.984"	øDs = 1.259"		FDM, FDS	FDE	FDFE, FDX	
3	1.035	1.311	3	2.126	1.732	0.787	∞
4	1.055	1.331	4	1.339	1.654	0.709	∞
5	1.035	1.311	5	1.929	1.969	0.787	∞
6	1.055	1.331	6	1.811	1.890	0.709	∞

STANDARD CUTTING CONDITIONS

ISO	Workpiece material	Hardness	Priority	Grade	Cutting speed Vc (sfm)
P	Steel (1045, 4135, etc.)	< 300 HB	First choice	AC22	160 - 600
		< 300 HB	Priority for wear resistance	AC22	260 - 660
		< 300 HB	Priority for impact resistance	TP222	160 - 400
		< 300 HB	Priority for surface finish	AC22	260 - 720
M	Stainless steel (304SS, 316SS, 17-4 PH, etc.)	< 200 HB	First choice	AC22	160 - 400
		< 200 HB	Priority for impact resistance	TP222	160 - 400
K	Gray cast iron (Class 25, Class 30, etc.)	-	First choice	TP222	160 - 600
	Ductile cast iron (60-40-18, 60-55-06, etc.)	-	First choice	TP222	160 - 400
S	Titanium alloys (Ti-6Al-4V, etc.)	< HRC 40	First choice	AC22	60 - 260
		< HRC 40	Priority for impact resistance	AC22	60 - 260

WORKPIECE MATERIAL AND APPLICATION

Grades	ISO	Characteristics & applications
AC22 PVD coated	<div style="display: flex; flex-wrap: wrap; gap: 5px;"> <div style="background-color: #0070C0; color: white; padding: 2px;">P20</div> <div style="background-color: #0070C0; color: white; padding: 2px;">P40</div> <div style="background-color: #FFD700; color: black; padding: 2px;">M20</div> <div style="background-color: #FFD700; color: black; padding: 2px;">M40</div> <div style="background-color: #8B0000; color: white; padding: 2px;">S20</div> <div style="background-color: #8B0000; color: white; padding: 2px;">S40</div> </div>	<ul style="list-style-type: none"> • General machining of steel • General machining of stainless steel • General machining of heat-resistant alloy
TP222 PVD coated	<div style="display: flex; flex-wrap: wrap; gap: 5px;"> <div style="background-color: #0070C0; color: white; padding: 2px;">P30</div> <div style="background-color: #0070C0; color: white; padding: 2px;">P50</div> <div style="background-color: #FFD700; color: black; padding: 2px;">M30</div> <div style="background-color: #FFD700; color: black; padding: 2px;">M50</div> <div style="background-color: #8B0000; color: white; padding: 2px;">S30</div> <div style="background-color: #8B0000; color: white; padding: 2px;">S50</div> </div>	<ul style="list-style-type: none"> • Interrupted and rough machining of steel • Interrupted and rough machining of stainless steel • Low speed and interrupted machining of heat-resistant alloy

CONTACT US



MEGA TECH METALWORK CO.,LTD (Headquarter)



Tel : 02-943-1591



Fax : 02-943-1592



Line ID : @mgt_metalwork



Email : sales.m@mgtg.co.th



Web : <https://www.mgtg.co.th/>



**17/4 Soi Ramintra 89
Ramintra Khannayao
Bangkok 10230**

