

NEW PRODUCT NEWS

**MEGA
TECH**
METAL WORK CO.,LTD

Taegutec Parting & Grooving Line

SLEEVE AND Y-AIX TYPE HOLDERS FOR SWISS TYPE MACHINES



ADVANCECUTTING
TaeguTec

TaeguTec
Member IMC Group

KEY POINT

TaeguTec introduces grooving and turning capable sleeve and Y-axis type holders for Swiss type machines.

TaeguTec's TQJ/S QUAD-RUSH and TQIS QUAD-I-RUSH economical 4-corner grooving insert lines, known for their unique shapes and strong clamping force, now include sleeve and Y-axis type holders that provide excellent turning and grooving performance that is required by the small parts machining industry. Additionally, external threading capable sleeve holders have been added to ensure product diversity.

Detailed information about the TQJ/S and TQIS inserts is available through our previously published NPNs.

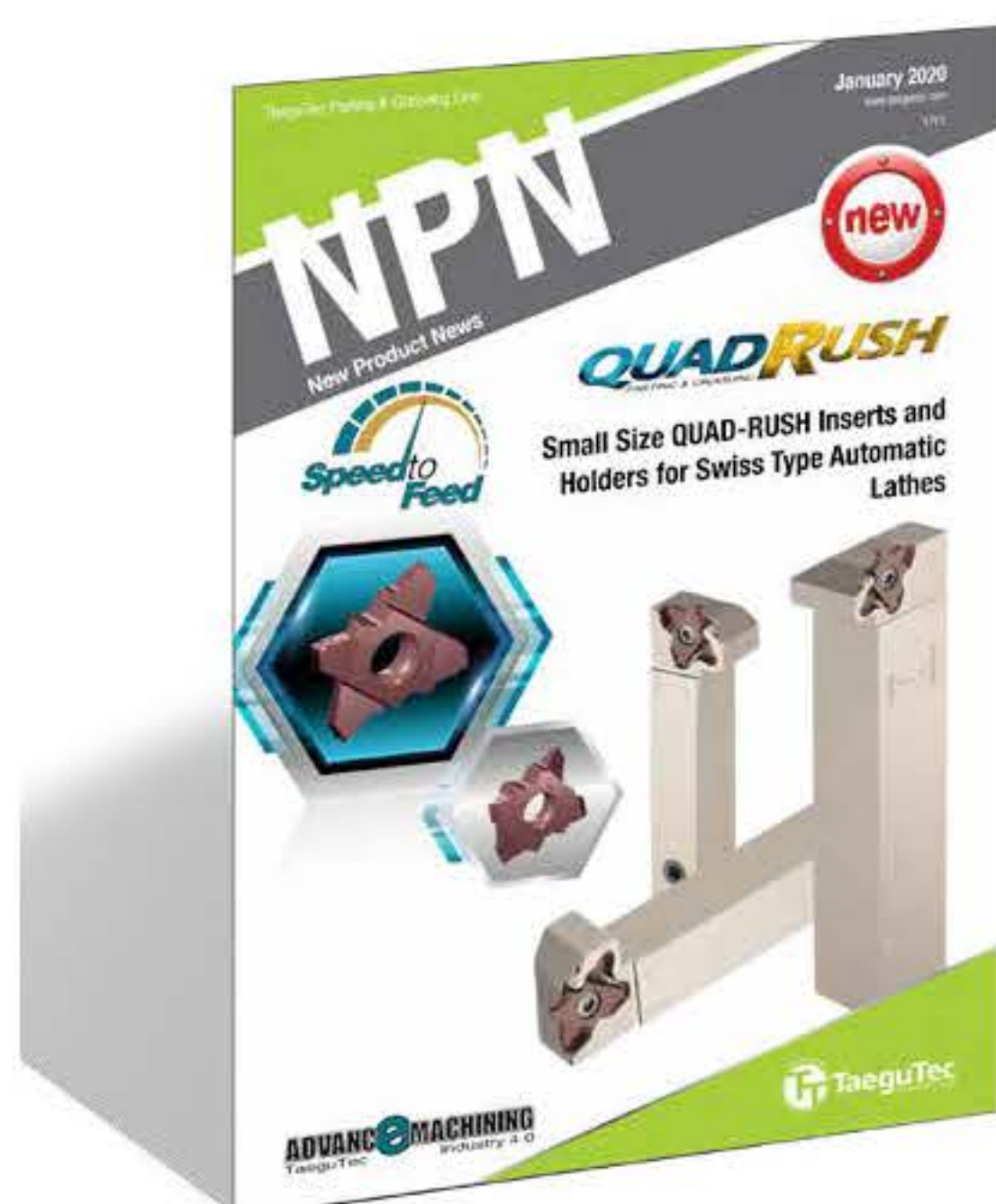

QUAD RUSH
PARTING & GROOVING



NPN
Download

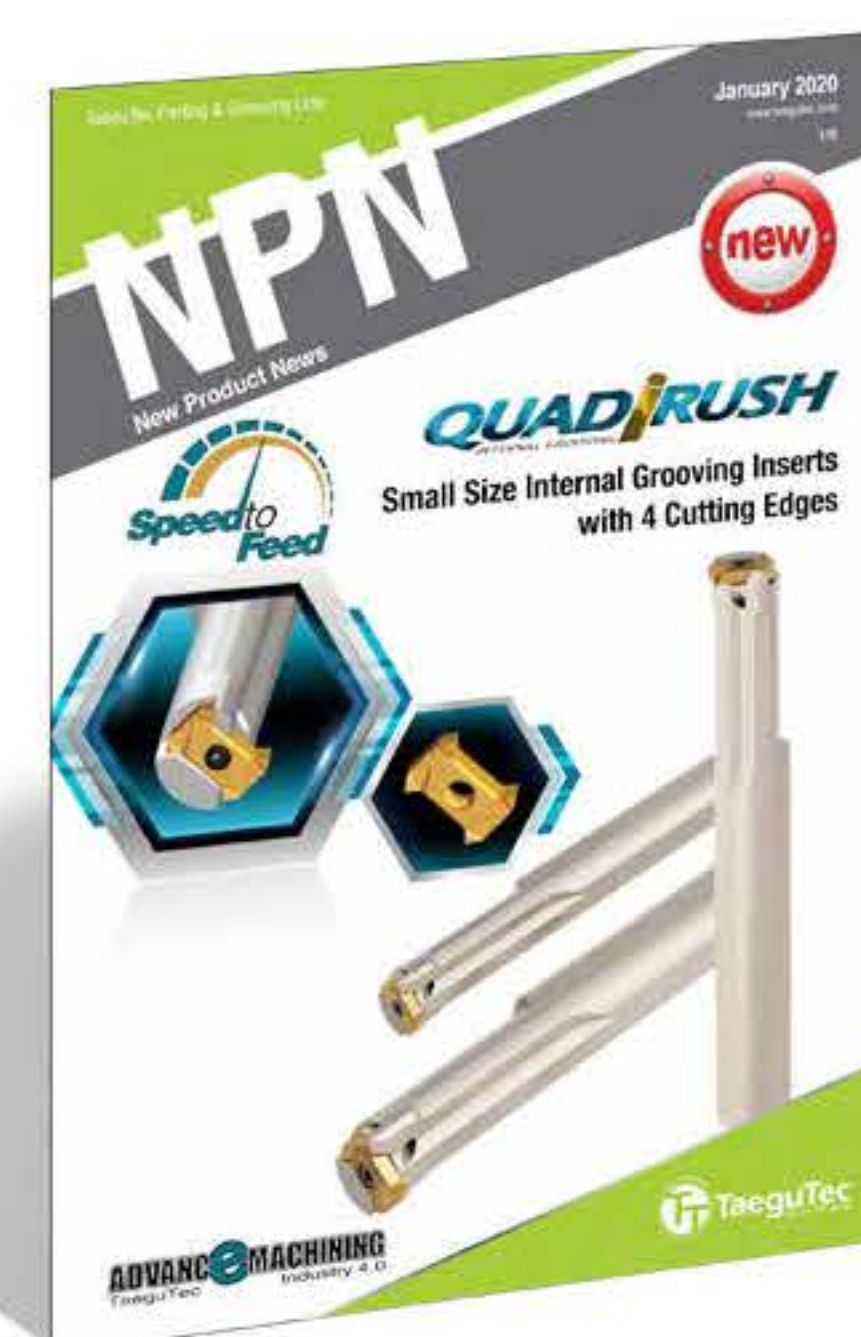

QUAD I RUSH
INTERNAL GROOVING



NPN
Download



Please contact the product manager for additional details.



Y-axis holders for main tool post
TMY-TQHR...(-TB)

Sleeve holders for rear tool post
TMS-TQHL...(-TB) /
TMS-TQHIL...(-TB) / TMS-SEL

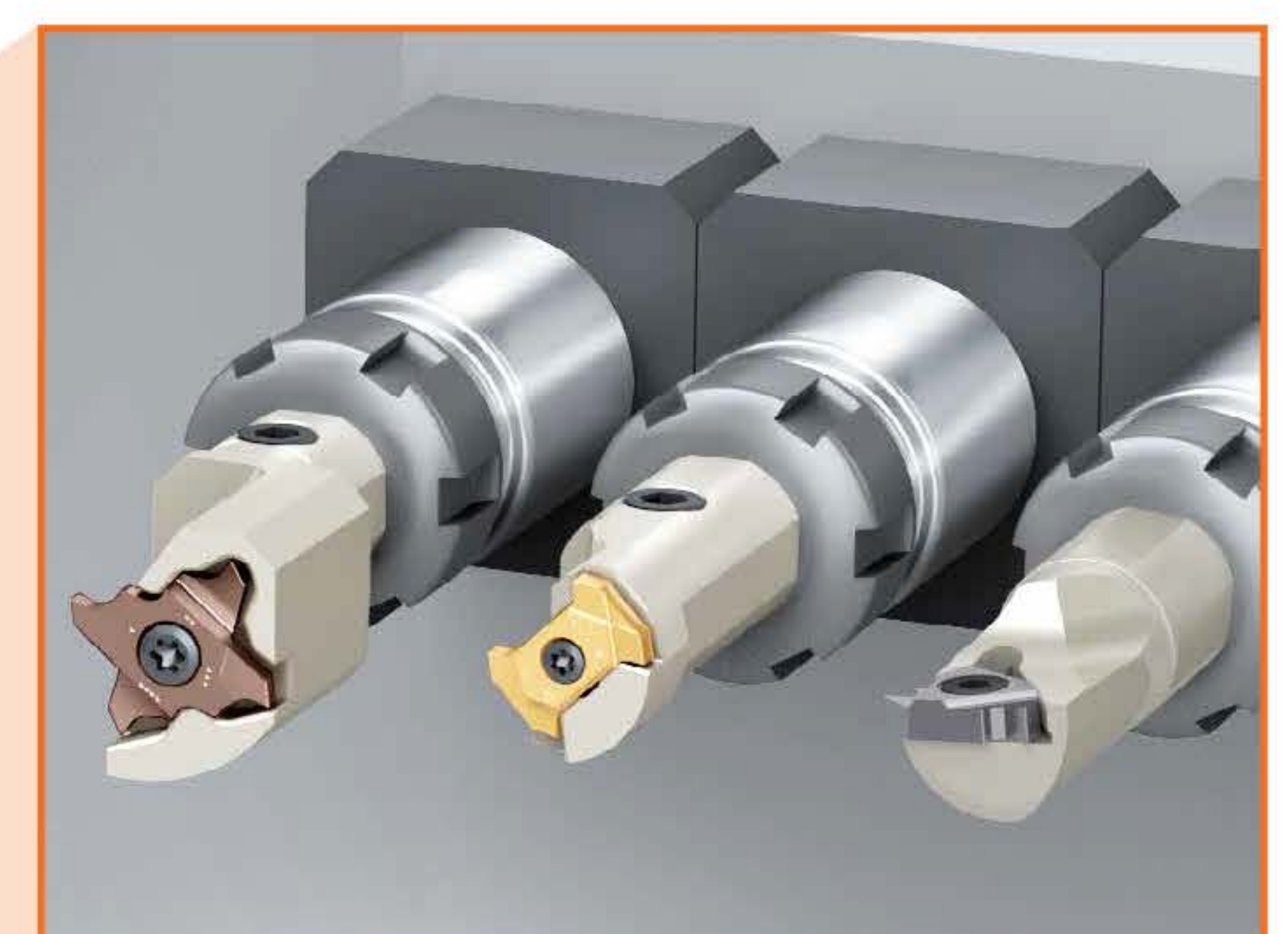

Sleeve holder features

- Economical insert type holders:
 - Turning and grooving insert: TQJ/S 20 and TQIS 14
 - Threading insert: 16ER
- Mountable to the rear tool post for external machining
 - Main tool post shortage issue resolved
- Available in various holder sizes for compatibility with all Swiss type machines
- COOL-BURST design for good chip evacuation and improved tool life

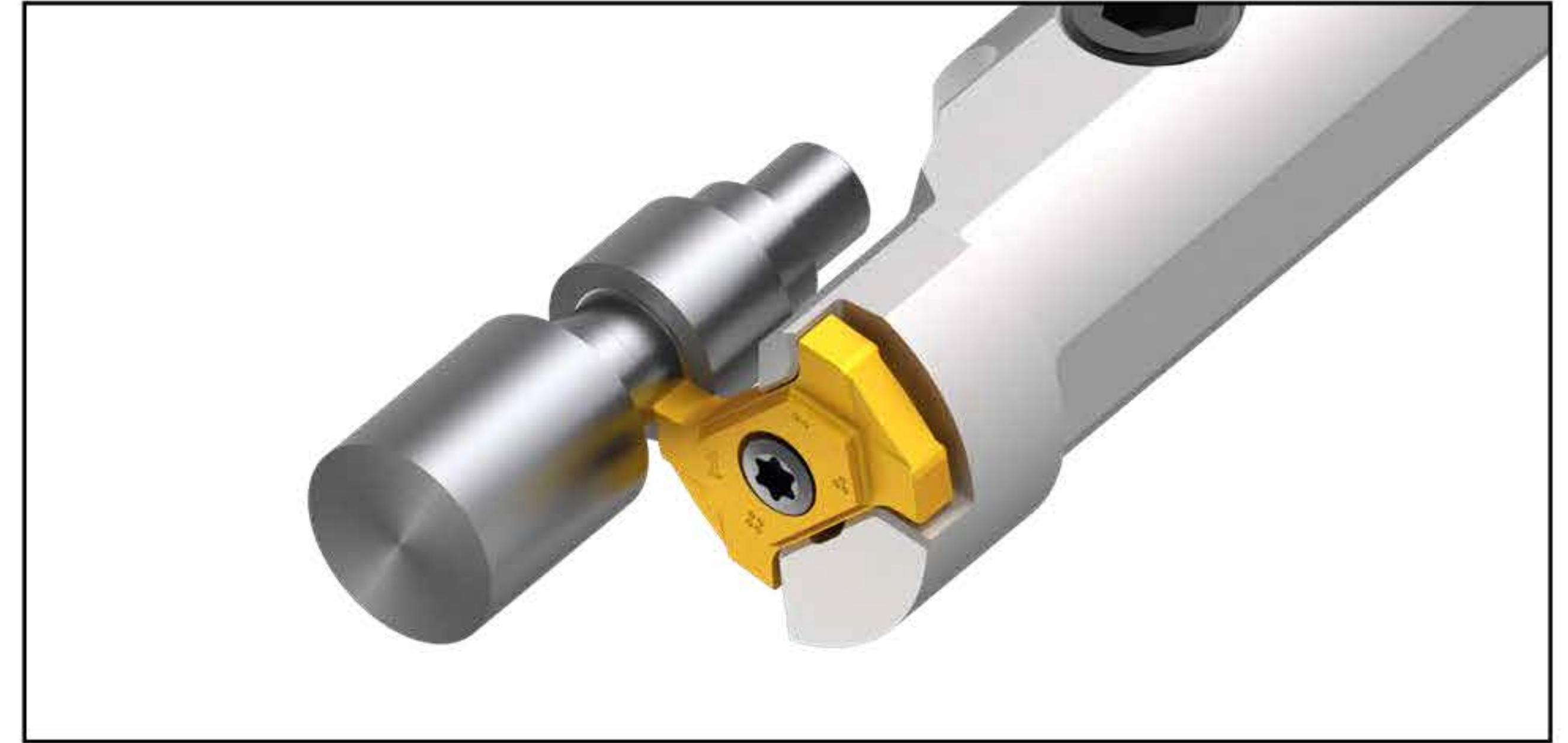

Y-axis holder features

- Economical 4-corner inserts: TQJ/S 20
- Mountable to the main tool post for Y-axis machining
 - Maximized holder rigidity against cutting force
 - Better dimensional accuracy for reduced vibration
 - Smooth chip evacuation as swarf falls downwards during machining
- COOL-BURST design for improved tool life
- Excellent chip segmentation even in difficult-to-cut materials machining

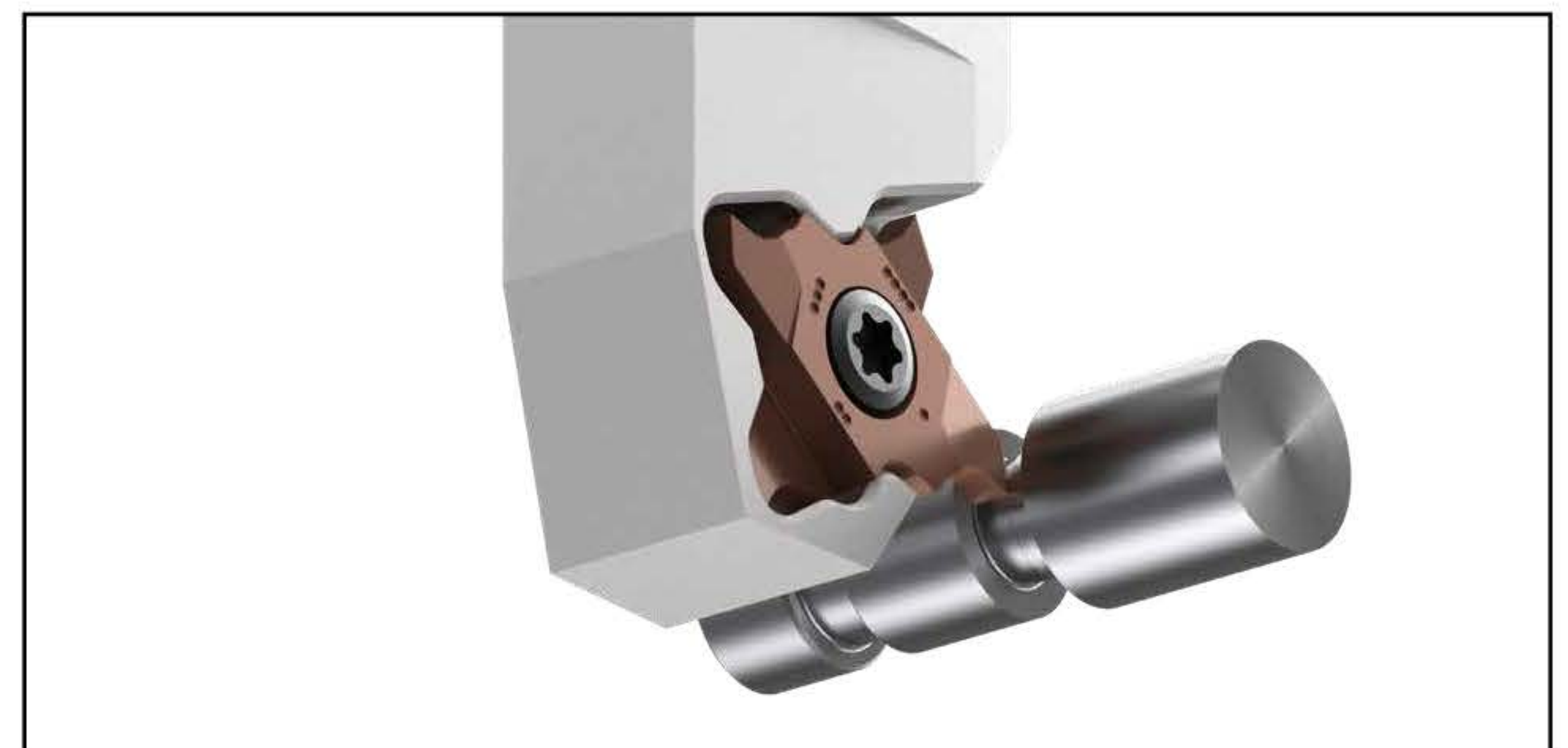

To set the cutting point of Y-axis type holders:

1. Apply the holder upper flat area to the workpiece.
2. Input the offset value measured between the flat and cutting point.
TMY-TQHL(-TB) holder offset value (DISTX): 6.3 mm

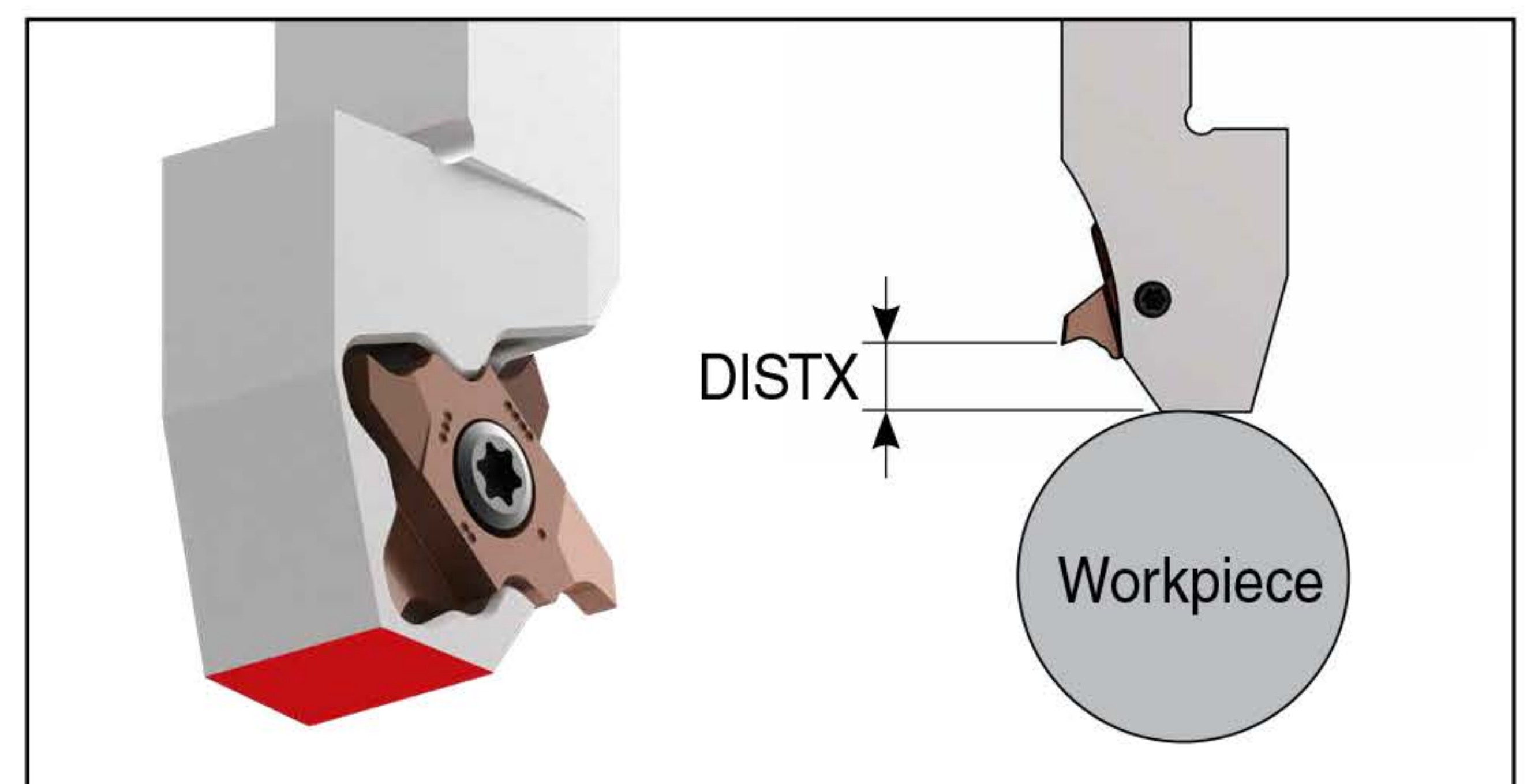

TMS-TQHL

Sleeve holders for external grooving

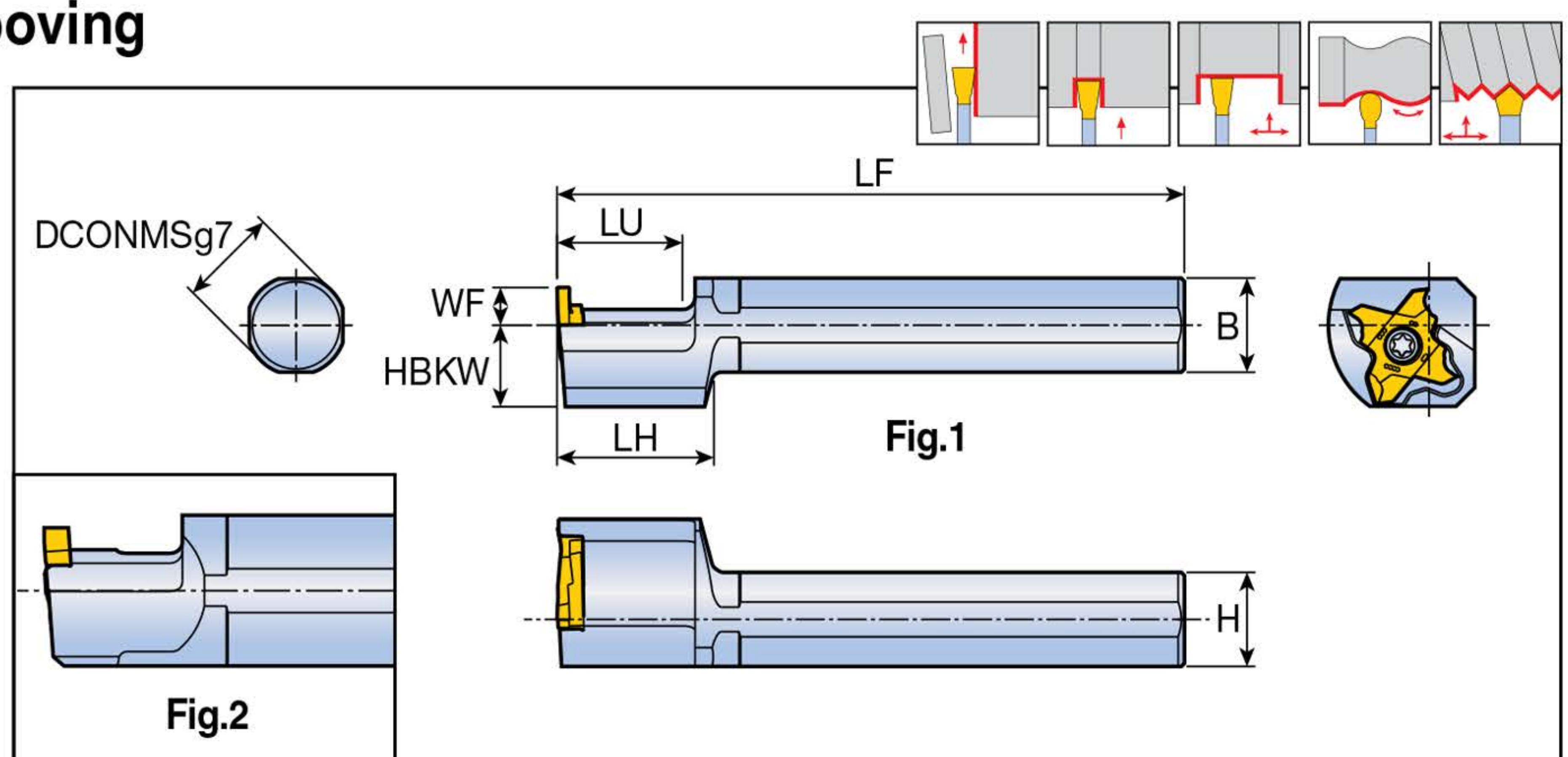

Designation	Dimension (mm)								Fig.	Insert
	DCONMS	H=B	LF	LU	LH	WF	HBKW			
TMS-TQHL 16-20	16	15	100	20	25	6	13	1	TQ...20-R	
19.05-20	19.05	18	100	20	25	6	13	1		
20-20	20	19	100	20	25	6	13	1		
22-20	22	21	100	20	25	6	13	1		
25-20	25	24	100	20	-	10	12	2		
25.4-20	25.4	24.4	100	20	-	10	12.2	2		

► TQ... 20-R insert for L-hand toolholder

TMS-TQHL-TB

Sleeve holders for external grooving with high pressure coolant

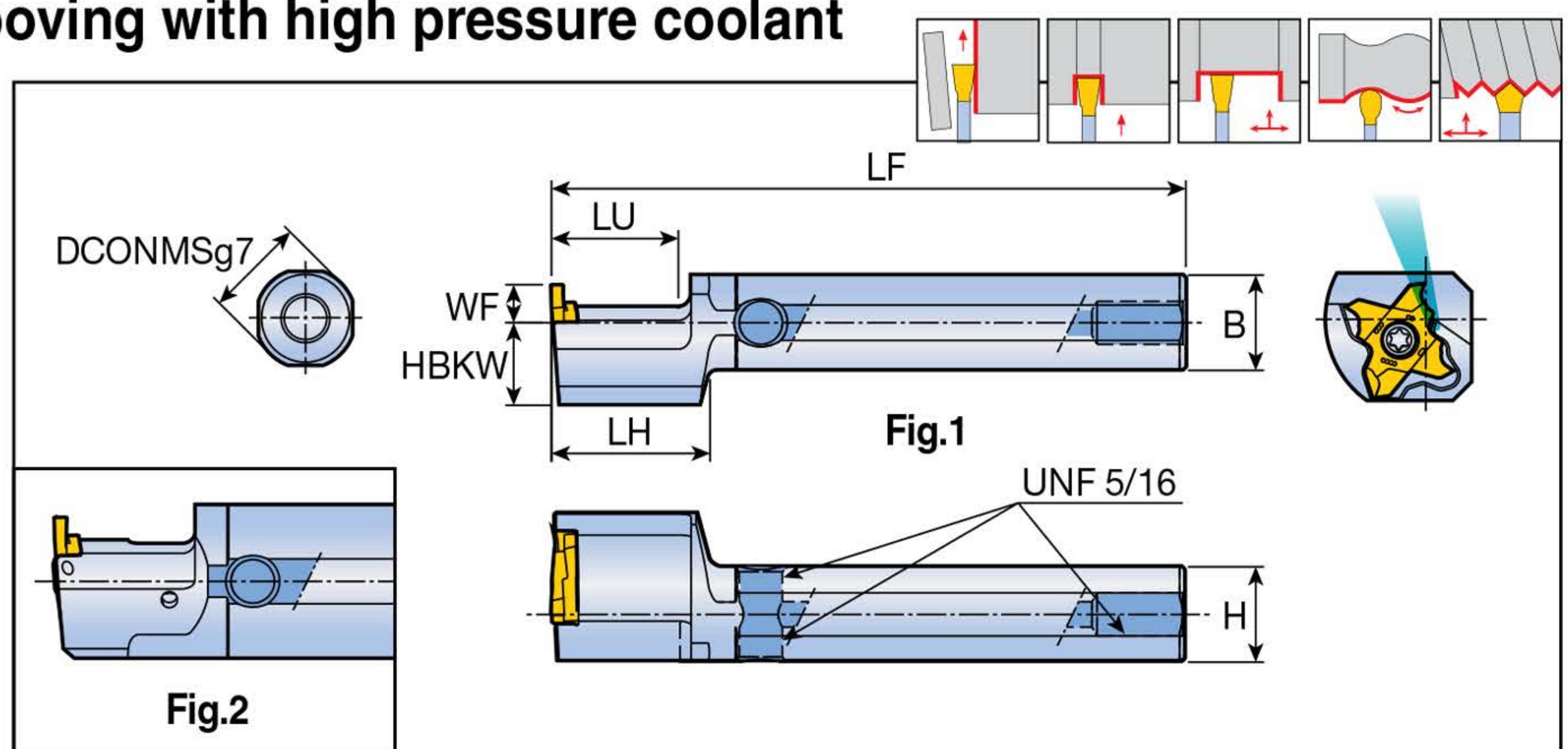

Designation	Dimension (mm)								Fig.	Insert
	DCONMS	H=B	LF	LU	LH	WF	HBKW			
TMS-TQHL 16-20-TB	16	15	100	20	25	6	13	1	TQ...20-R	
25-20-TB	25	24	100	20	-	10	12	2		

► TQ... 20-R insert for L-hand toolholder

Spare parts

Designation	Screw	Wrench		Plug
TMS-TQHL	TS 40A100L	T-1508/5	-	-
TMS-TQHL-TB	TS 40A100L	T-1508/5	L-W 5/32	PLG 5/16 UNF

TMY-TQHR



Y-axis holders for parting and grooving

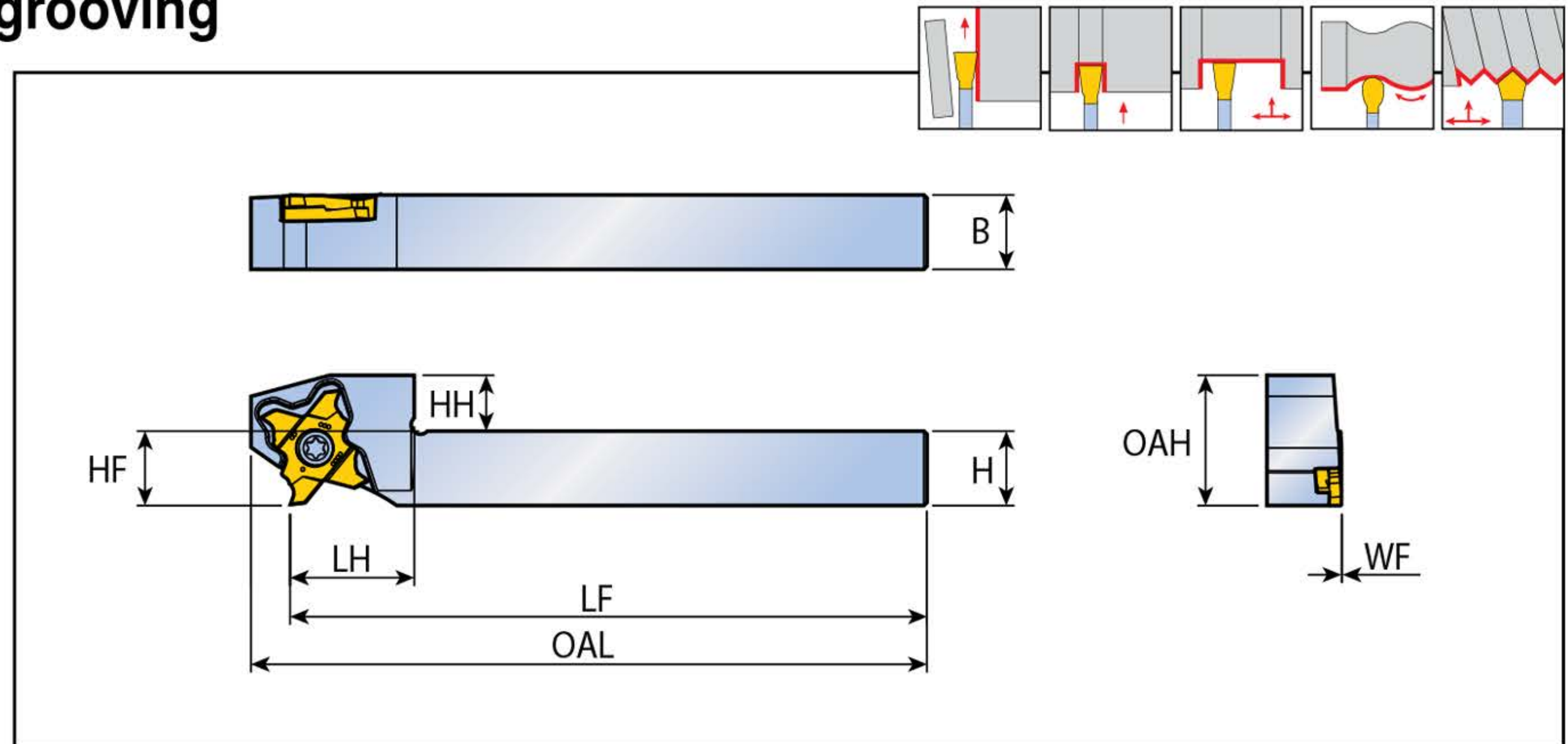

Designation	Dimension (mm)									Insert
	H	B	HH	LH	HF	WF	OAH	LF	OAL	
TMY-TQHR 10-20	10	10	11	20	10	0	21	125	131.3	TQ...20-R
12-20	12	12	9	20	12	0	21	125	131.3	
16-20	16	16	5	20	16	0	21	125	131.3	

TMY-TQHR-TB



Y-axis holders for parting and grooving with high pressure coolant

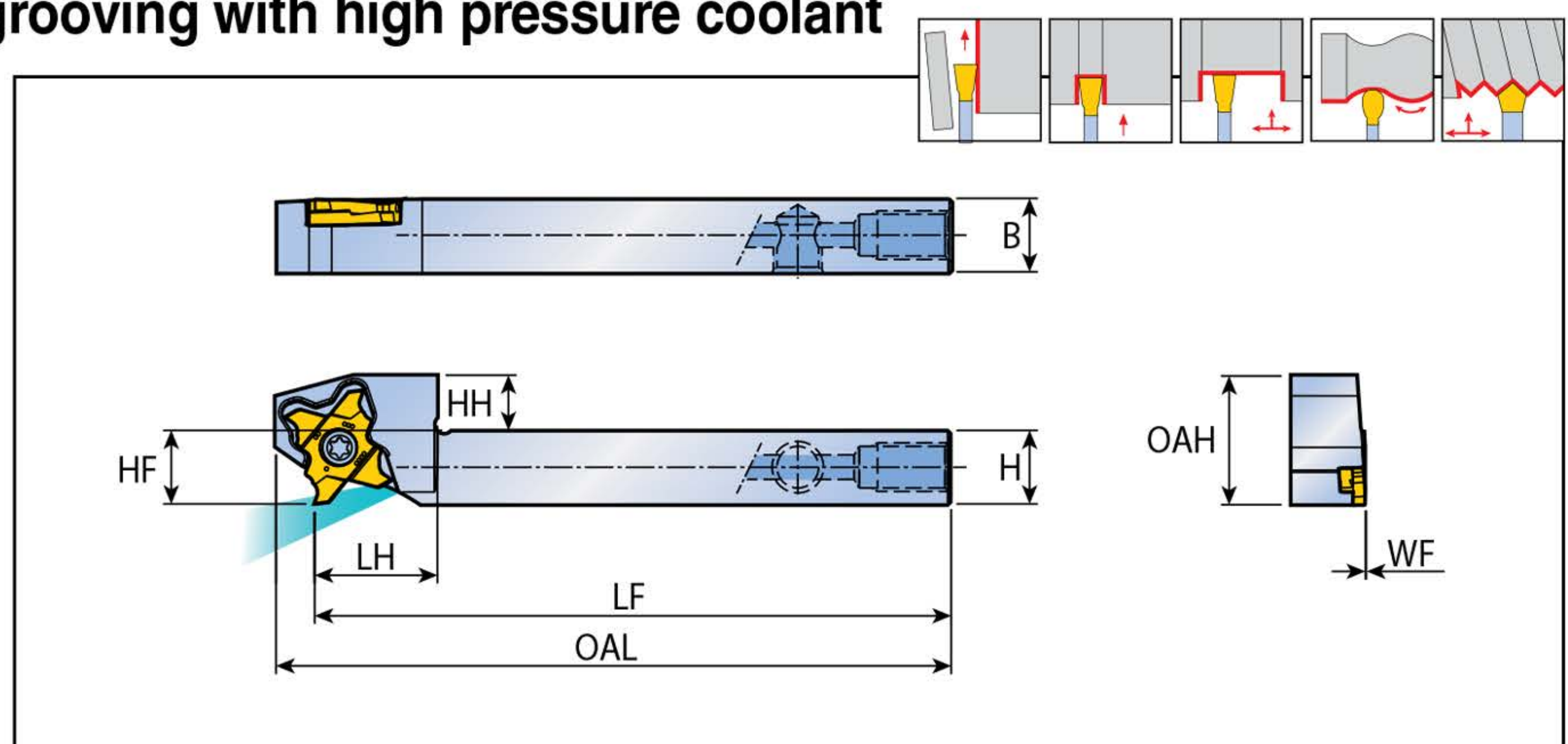

Designation	Dimension (mm)									Insert
	H	B	HH	LH	HF	WF	OAH	LF	OAL	
TMY-TQHR 12-20-TB	12	12	9	20	12	0	21	125	131.3	TQ...20-R
16-20-TB	16	16	5	20	16	0	21	125	131.3	

Spare parts

Designation	Screw	Wrench		Plug
	TMY TQHR	TS 40A100L	T-1508/5	-
TMY TQHR-TB	TS 40A100L	T-1508/5	L-W 5/32	PLG 5/16 UNF

TMS-TQHIL



Sleeve holders for external grooving

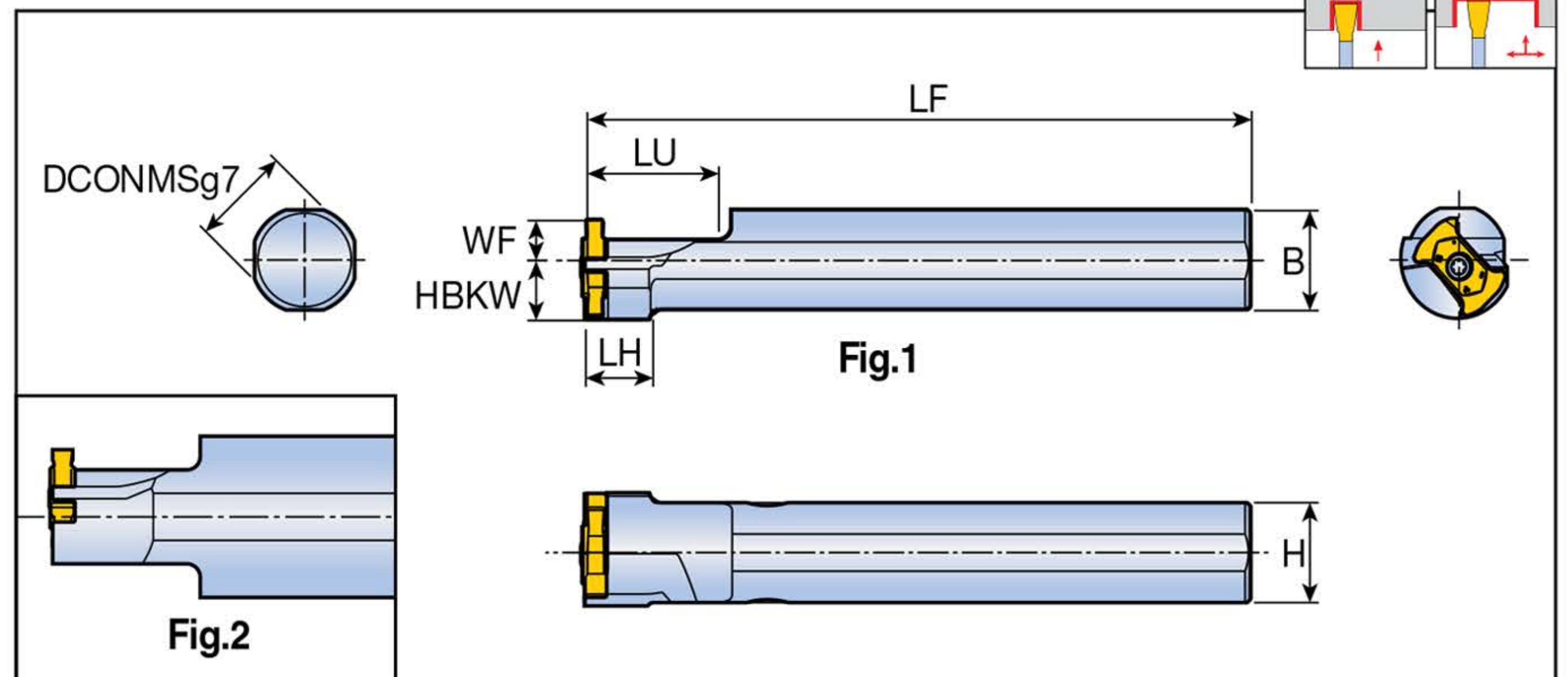

Designation	Dimension (mm)							Fig.	Insert
	DCONMS	H=B	LF	LU	LH	WF	HBKW		
TMS-TQHIL 16-14	16	15	100	20	10	6	9	1	TQIS 14
19.05-14	19.05	18	100	20	-	6	9	1	
20-14	20	19	100	20	20	6	9	2	
22-14	22	21	100	20	22	10	7	2	
25-14	25	24	100	20	22	10	7	2	
25.4-14	25.4	24.4	100	20	22	10	7	2	

TMS-TQHIL-TB



Sleeve holders for external grooving with high pressure coolant

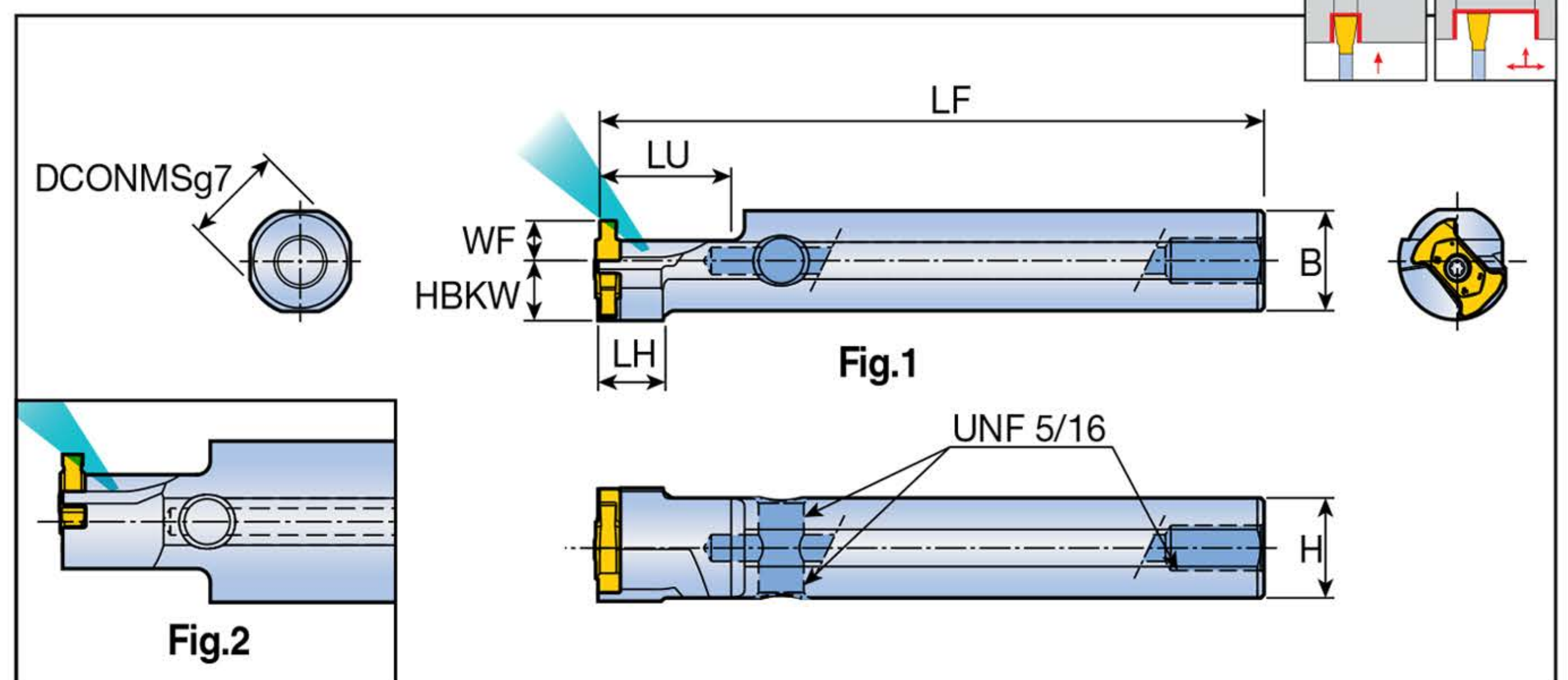

Designation	Dimension (mm)							Fig.	Insert
	DCONMS	H=B	LF	LU	LH	WF	HBKW		
TMS-TQHIL 16-14-TB	16	15	100	20	10	6	9	1	TQIS 14
25-14-TB	25	24	100	20	22	10	5	2	

Spare parts

Designation	Screw	Wrench		Plug
	TMS-TQHIL	TS 25075I/HG	T 8	-
TMS-TQHIL-TB	TS 25075I/HG	T 8	L-W 5/32	PLG 5/16 UNF

TMS-SEL

T-THREAD

Sleeve holders for external threading

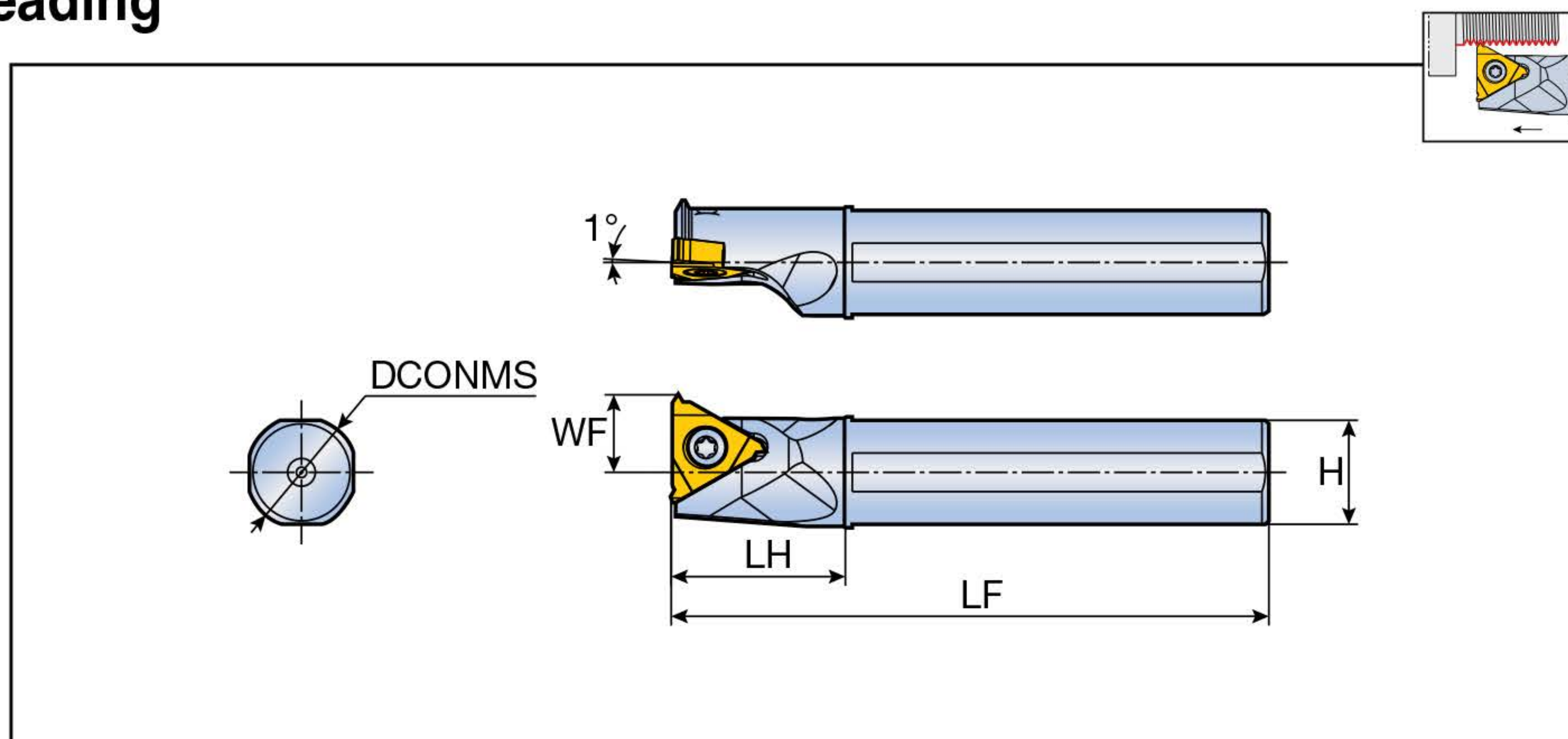

Designation	Dimension (mm)					Insert
	DCONMS	H	LF	LH	WF	
TMS-16F SEL 16	16	15	85	25	11	16 ER...
19G SEL 16	19.05	18	90	30	12.5	
19X SEL 16	19.05	18	120	30	12.5	
20G SEL 16	20	19	90	30	13	
20X SEL 16	20	19	120	30	13	
25H SEL 16	25	24	100	30	15.5	
254X SEL 16	25.4	24	120	30	15.7	

► Use left hand toolholders (L) with right hand insert (ER)

Spare parts

Designation	Screw	Wrench		
	TMS-SEL	S16	T-10/5	

CONTACT US



MEGA TECH METALWORK CO.,LTD (Headquarter)



Tel : 02-943-1591



Fax : 02-943-1592



Line ID : @mgt_metalwork



Email : sales.m@mgtg.co.th



Web : <https://www.mgtg.co.th/>



**17/4 Soi Ramintra 89
Ramintra Khannayao
Bangkok 10230**

