

NEW PRODUCT NEWS



JRF Milling Cutter

JRF Milling Cutter

For Heat-Resistant Alloys | Ceramics

NTK'S PURSUIT OF THE ULTIMATE CUTTER'S BIRTH



CERtainly [but not only] **CERamics**
Outstanding solutions for demanding applications

JRF Milling Cutter

Introducing a New Paradigm in Ceramic-Embedded Cutters

NTK Achieves Industry-First Triple-Blade Configuration with Ceramic Negative Inserts for $\phi 16$ Cutters
 By utilizing double-sided, high-strength negative inserts and the high efficiency of three blades, NTK contributes to cost-effective tooling, stable machining processes, and enhanced productivity.



Enhancing Machining Efficiency Further with Increased Insert Count



JRF Cutter (Negative insert)	Conventional (Positive insert)

High-Efficiency Machining with 3-insert Design
 at $\phi 16$ - Supports Maximum Table Feed of 7200mm/min!

Economical with Double-Sided Usable Negative Inserts

● Usable Corner

JRF Cutter (Negative insert)	Conventional (Positive insert)

JRF Milling Cutter



Extended Lifespan Chipbreaker

Our Step Chipbreaker: Reduces Flaking by Lowering the Cutting Edge from the Clamping Surface of Conventional (Positive Insert) Tools.

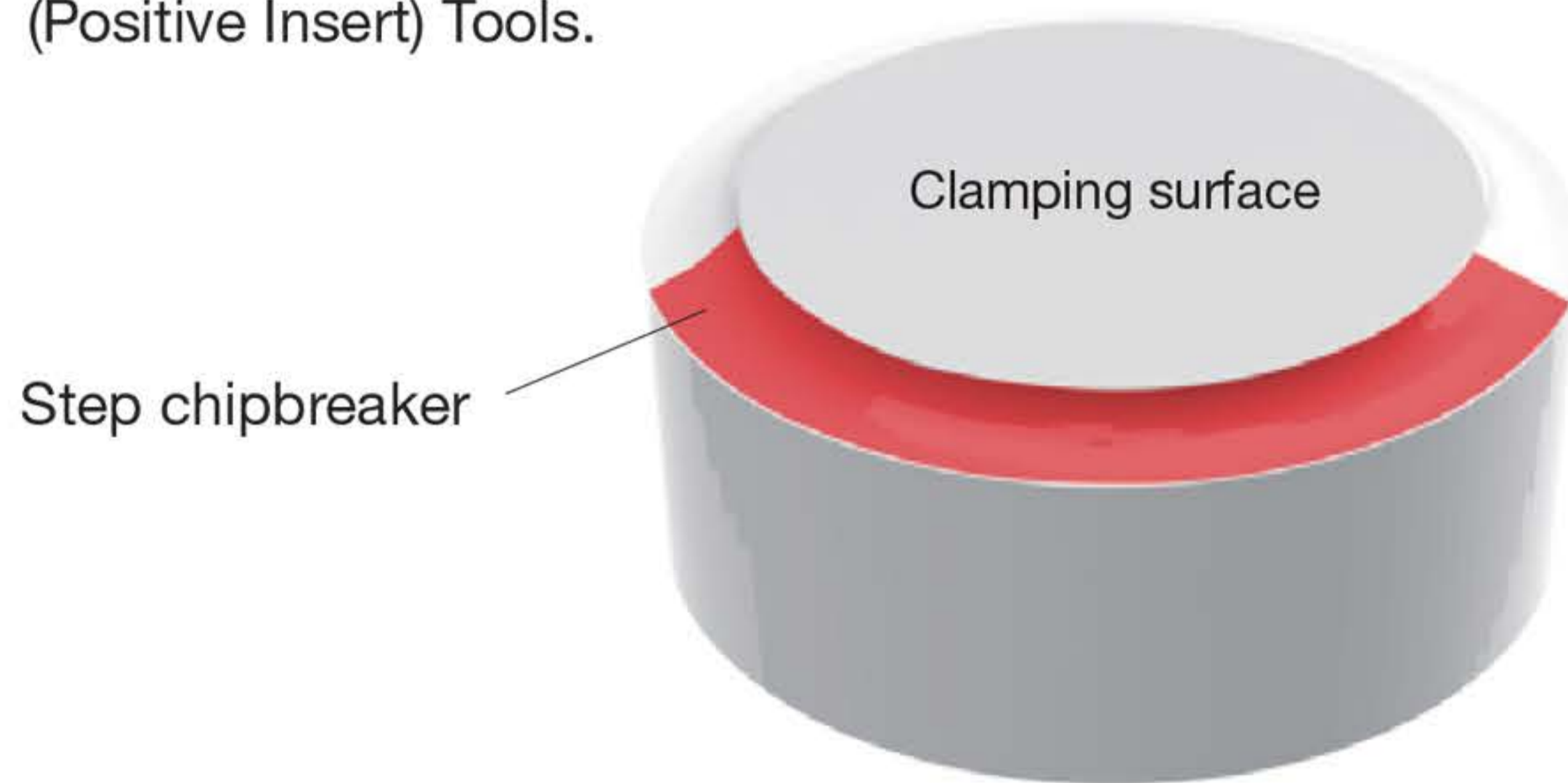

Prevent Insert Movement During Machining with Increased Clamping Force

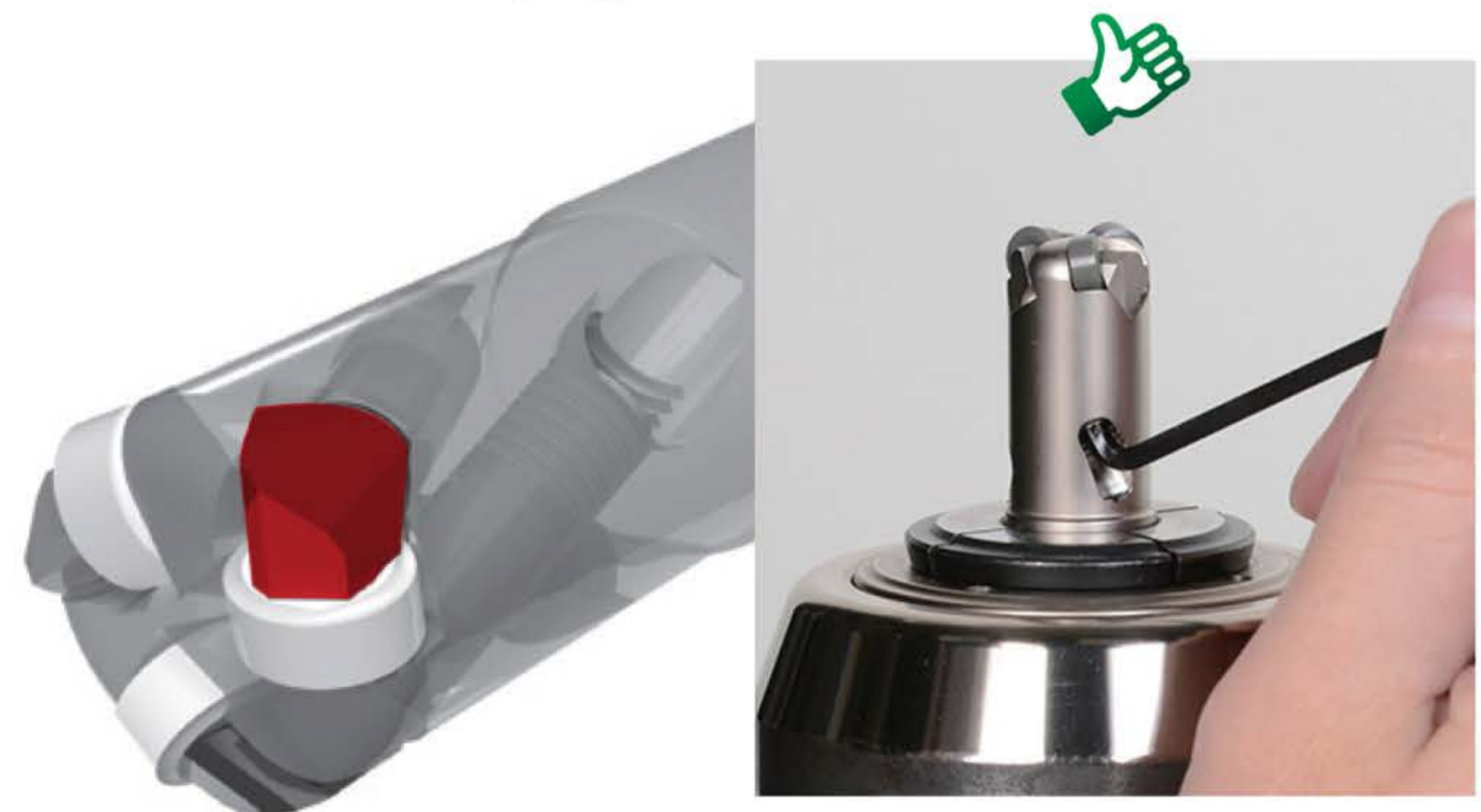

Insert Damage Suppression with Chipbreaker-Equipped Negative Inserts and Increased Clamping Force!

	JRF Cutter (Negative insert)	Competitor (Positive insert)	
Number of teeth (pc)	3 ($\Phi 16$)	2 ($\Phi 16$)	
Table feed (mm/min)	2,250	1,500	
Edge Damage			
Workpiece Material	Waspaloy (Combustion Casing)	Feed per tooth (mm/t)	0.075
Cutting Speed (m/min)	500 (10,000rpm)	D.O.C.(mm)	0.5

JRF Milling Cutter

Recommended Machining Parameters

Grade	Workpiece Material	Machining process	Cutting conditions			DRY	WET
			Cutting Speed (m/min)	Feed (mm/t)	D.O.C. (mm)		
SX3 SX9	HRSA	Milling	400 - 700 - 1000	0.08 - 0.10 - 0.12	- 1.0	●	×

Material-Specific Characteristics

SX3

The First Recommended Material for Machining Heat-Resistant Alloys with Ceramics: Balancing Wear Resistance and Fracture Resistance.

SX9

Ceramic Material Prioritizing Fracture Resistance

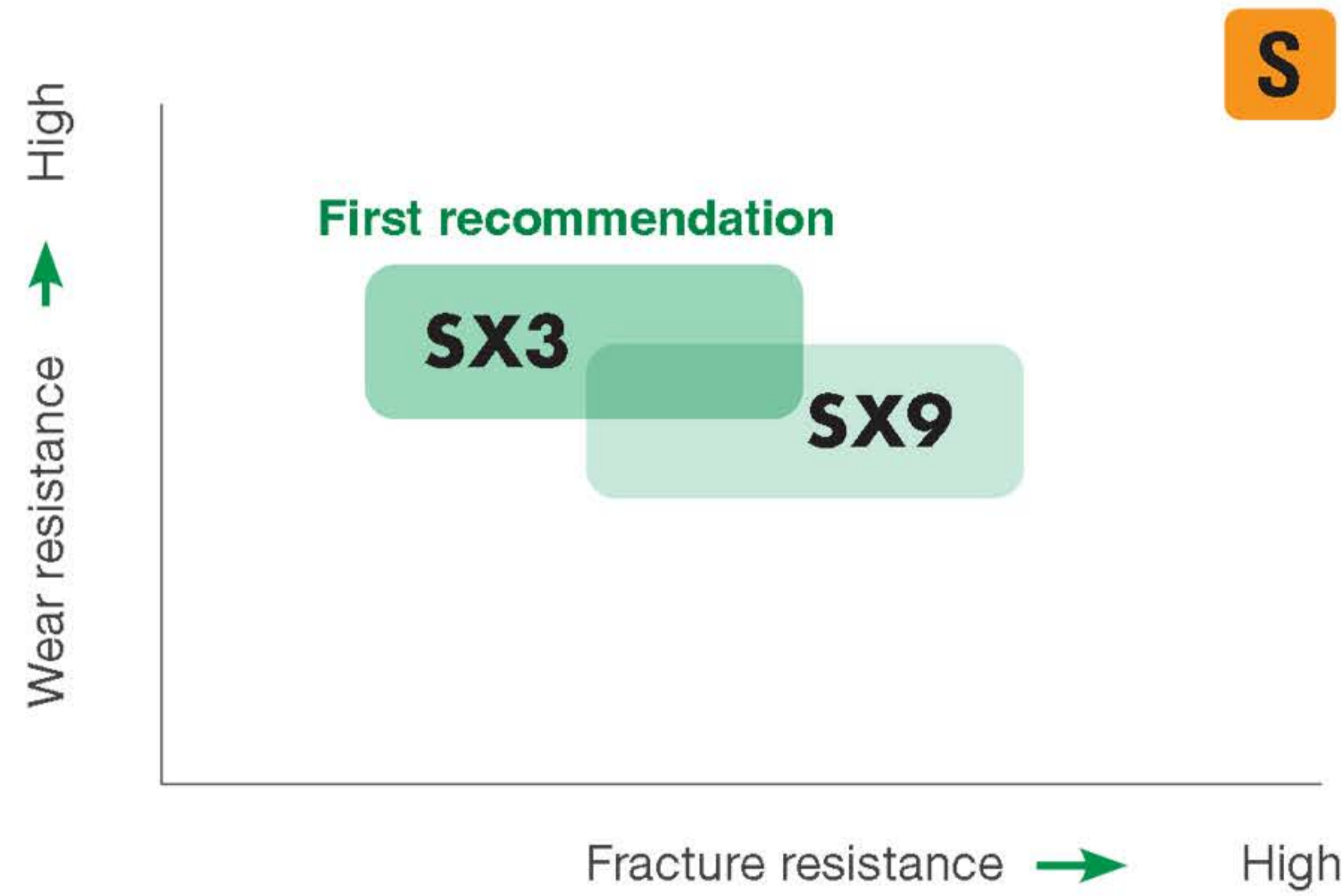

Case study

Waspaloy (Combustion Casing)

	JRF Cutter	Conventional
Grade	SX9 Negative insert	SX9 Positive insert
Teeth per body	5 (Φ32)	3 (Φ32)
Speed (m/min)	800 (8,000rpm)	800 (8,000rpm)
Feed per tooth (mm/t)	0.05	0.05
Table feed (mm/min)	2,000	1,200
D.O.C. (mm)	1.0	1.0
Tool life	2 pass	1 pass
Number of usable corners	8	5

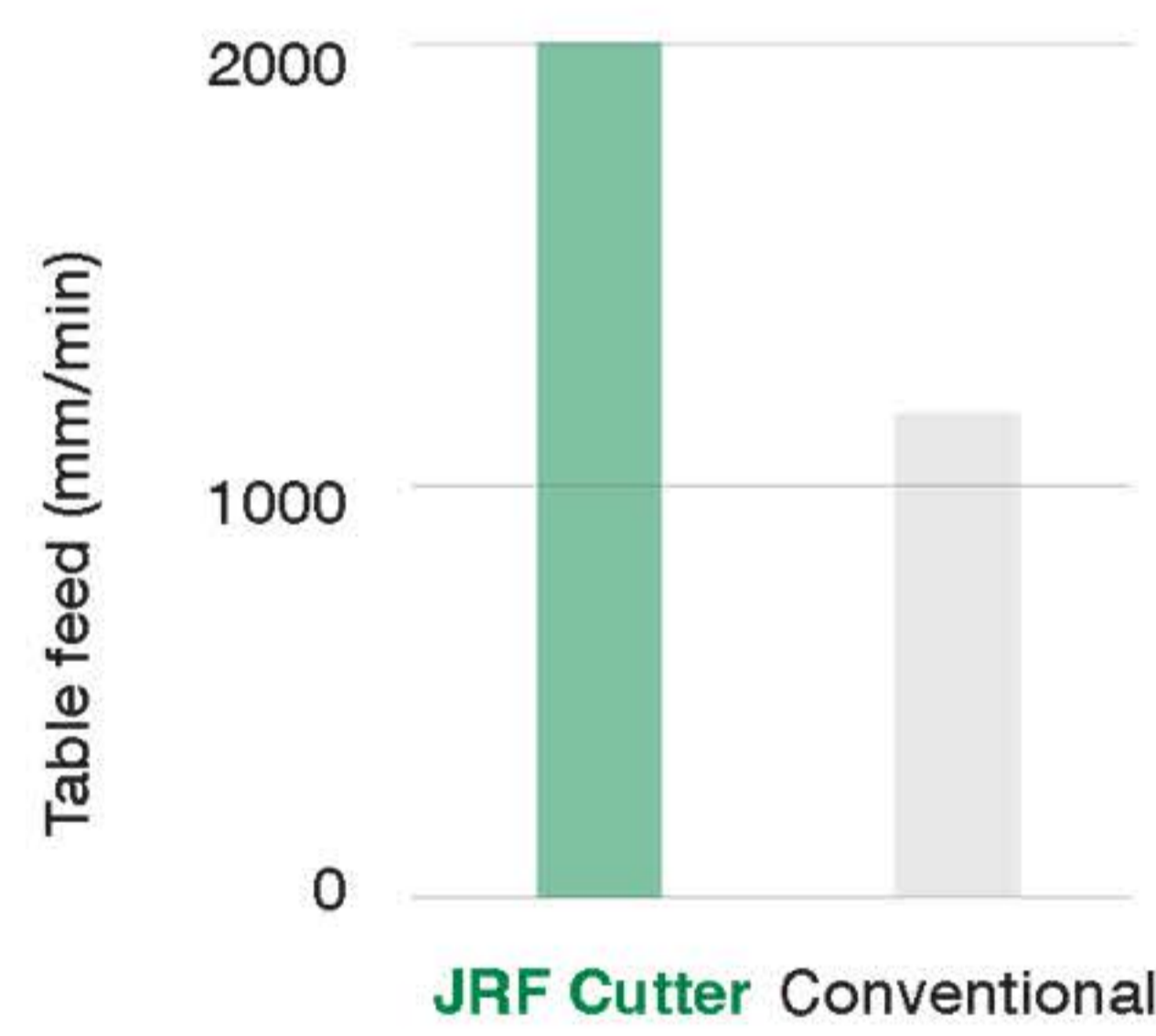

1.7 Times Efficiency

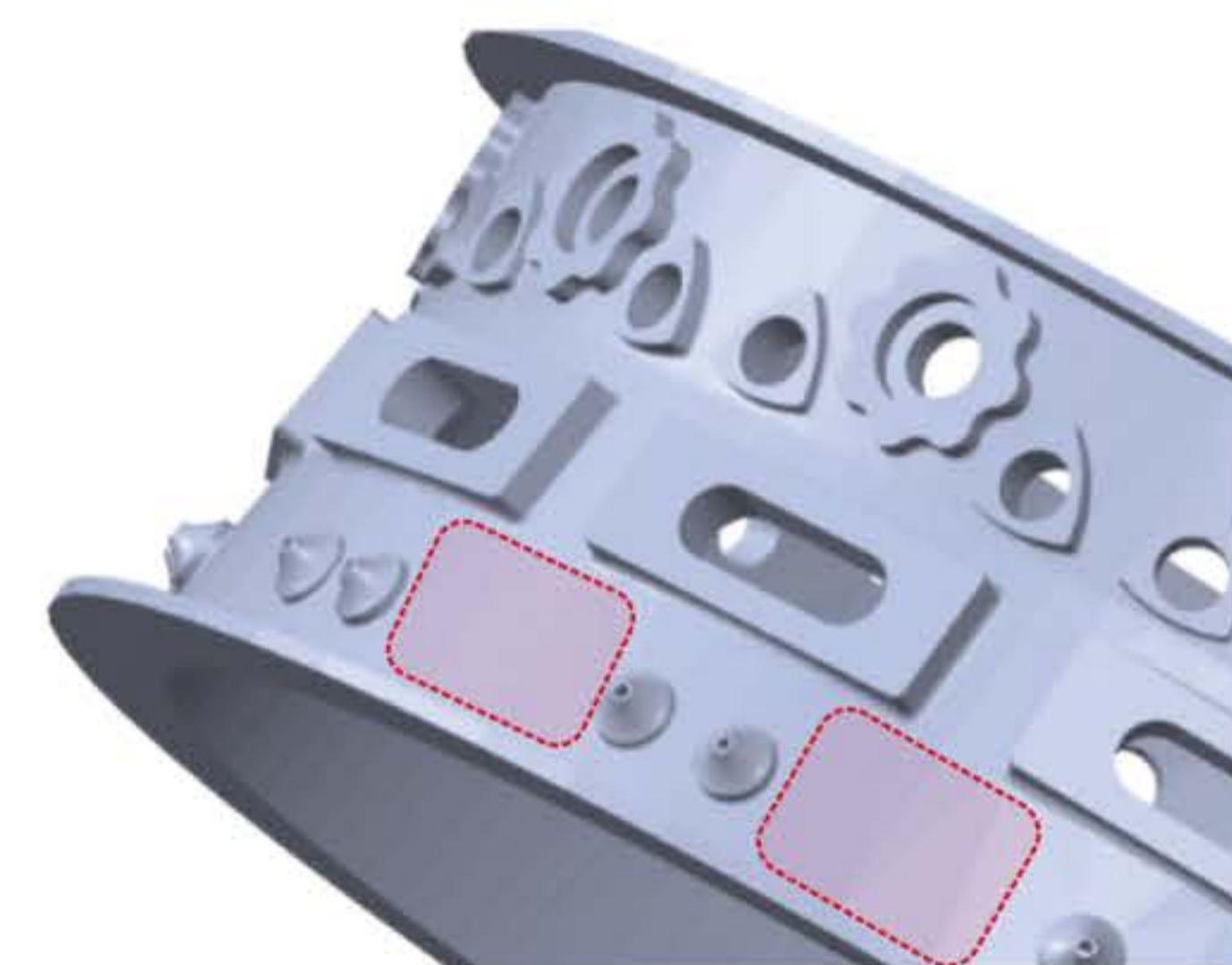

32% Reduction in Tooling Costs

Chip Price ÷ Number of Corners (tool life) x Number of inserts



JRF Milling Cutter

JRF Series / Cutter body Shank type

JRFMH Metric Size

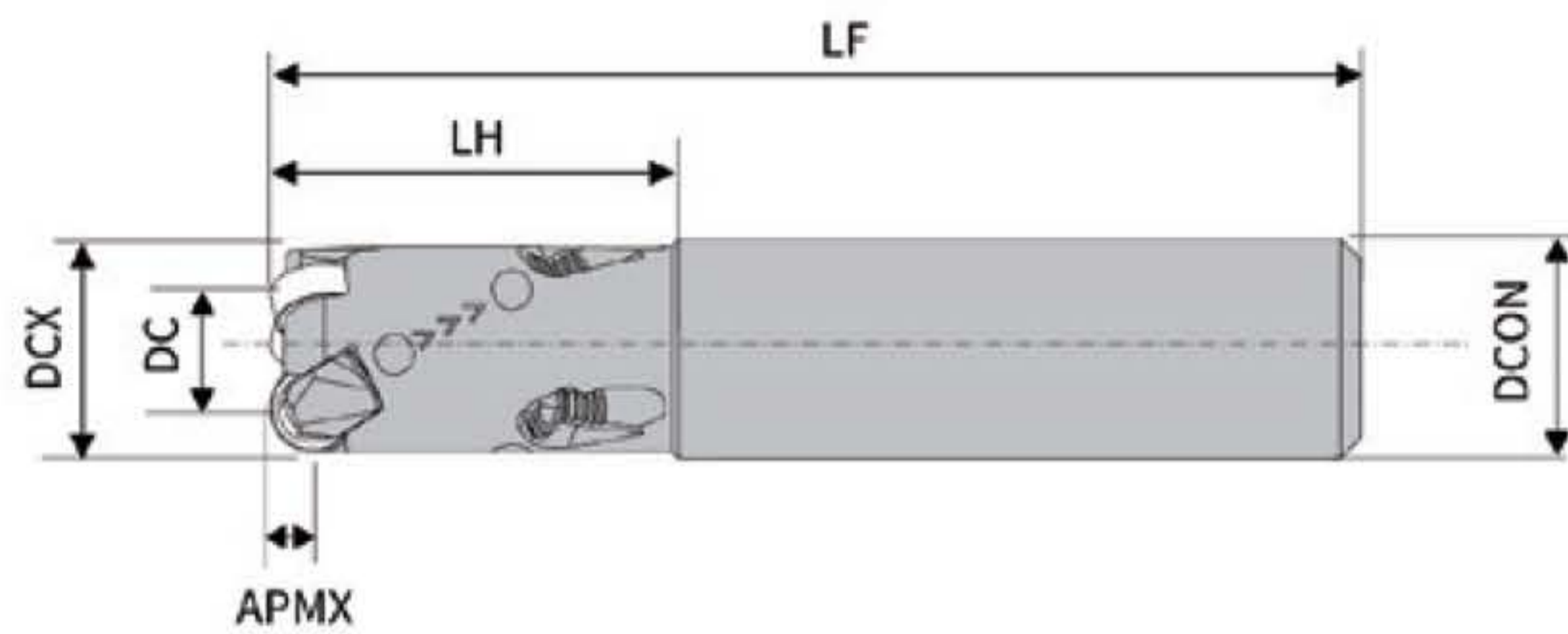

Cutter Item number	Stock	Hand	Tooth	APMX mm	DC mm	DCON mm	DCX mm	GAMF (R.R.)°	GAMP (A.R.)°	LF mm	LH mm	Insert
JRFMH016E160R03	●	R	3	~1.0	9.65	16	16	-20	-10	80	30	RNGF0603...
JRFMH020E200R03	●	R	3	~1.0	13.65	20	20	-20	-10	100	40	RNGF0604...
JRFMH025E250R03	●	R	3	~1.0	15.475	25	25	-25	-12	100	40	RNGF0904...
JRFMH025E250R04	●	R	4	~1.0	18.65	25	25	-25	-10	100	40	RNGF0604...
JRFMH032E320R03	●	R	3	~1.0	19.3	32	32	-25	-12	120	50	RNGF1204...
JRFMH032E320R04	●	R	4	~1.0	22.475	32	32	-28	-15	120	50	RNGF0904...
JRFMH032E320R05	●	R	5	~1.0	22.475	32	32	-25	-15	120	50	RNGF0904...

Parts

Item number	Wedge Screw	Cap screw	Wrench	Wrench (sold separately)
JRFMH016E160R03	HCS3P050	HWS3P050	LW-2.5S	(DL-025-08-JRF)
JRFMH020E200R03	HCS3P050	HWS3P050	LW-2.5S	(DL-025-08-JRF)
JRFMH025E250R03	HCS5P080	HWS5P080	LW-4.0	(DL-040-20-JRF)
JRFMH025E250R04	HCS3P050	HWS3P050	LW-2.5	(DL-025-20-JRF)
JRFMH032E320R03	HCS5P080	HWS5P080	LW-4.0	(DL-040-20-JRF)
JRFMH032E320R04	HCS5P080	HWS5P080	LW-4.0	(DL-040-20-JRF)
JRFMH032E320R05	HCS3P050	HWS3P050	LW-2.5	(DL-025-20-JRF)

JRFIH Inch Size

Cutter Item number	Stock	Hand	Tooth	APMX mm	DC mm	DCON mm	DCX mm	GAMF (R.R.)°	GAMP (A.R.)°	LF mm	LH mm	Insert
JRFIH0625E0625R03	●	R	3	~1.0	9.525	15.875	15.875	-20	-10	80.264	30.264	RNGF0603...
JRFIH075E075R03	●	R	3	~1.0	12.7	19.05	19.05	-20	-10	101.6	41.6	RNGF0604...
JRFIH100E100R03	●	R	3	~1.0	15.875	25.4	25.4	-25	-12	101.6	41.6	RNGF0904...
JRFIH100E100R04	●	R	4	~1.0	19.05	25.4	25.4	-25	-10	101.6	41.6	RNGF0604...
JRFIH125E125R03	●	R	3	~1.0	19.05	31.75	31.75	-25	-12	120.015	50.015	RNGF1204...
JRFIH125E125R04	●	R	4	~1.0	22.225	31.75	31.75	-28	-15	120.015	50.015	RNGF0904...
JRFIH125E125R05	●	R	5	~1.0	22.225	31.75	31.75	-25	-15	120.015	50.015	RNGF0904...

Parts

Item number	Wedge Screw	Cap screw	Wrench	Wrench (sold separately)
JRFIH0625E0625R03	HCS3P050	HWS3P050	LW-2.5S	(DL-025-08-JRF)
JRFIH075E075R03	HCS3P050	HWS3P050	LW-2.5S	(DL-025-08-JRF)
JRFIH100E100R03	HCS5P080	HWS5P080	LW-4.0	(DL-040-20-JRF)
JRFIH100E100R04	HCS3P050	HWS3P050	LW-2.5	(DL-025-20-JRF)
JRFIH125E125R03	HCS5P080	HWS5P080	LW-4.0	(DL-040-20-JRF)
JRFIH125E125R04	HCS5P080	HWS5P080	LW-4.0	(DL-040-20-JRF)
JRFIH125E125R05	HCS3P050	HWS3P050	LW-2.5	(DL-025-20-JRF)

JRF Milling Cutter

JRF Series / Inserts

■ RNGF

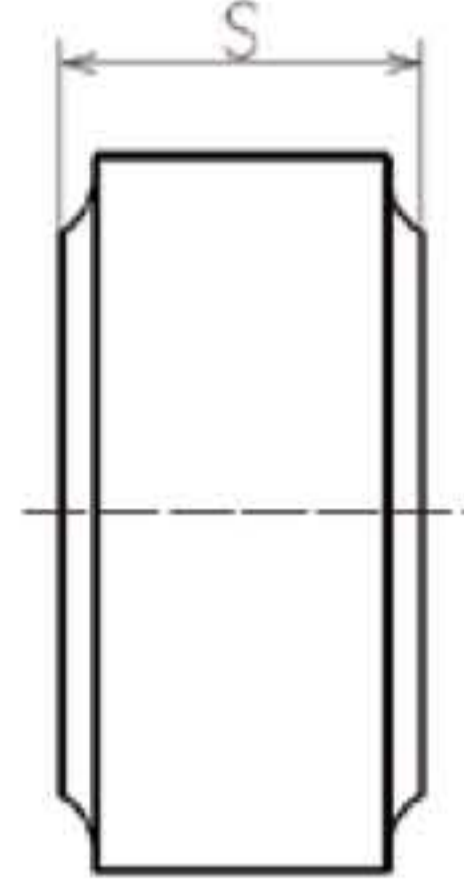
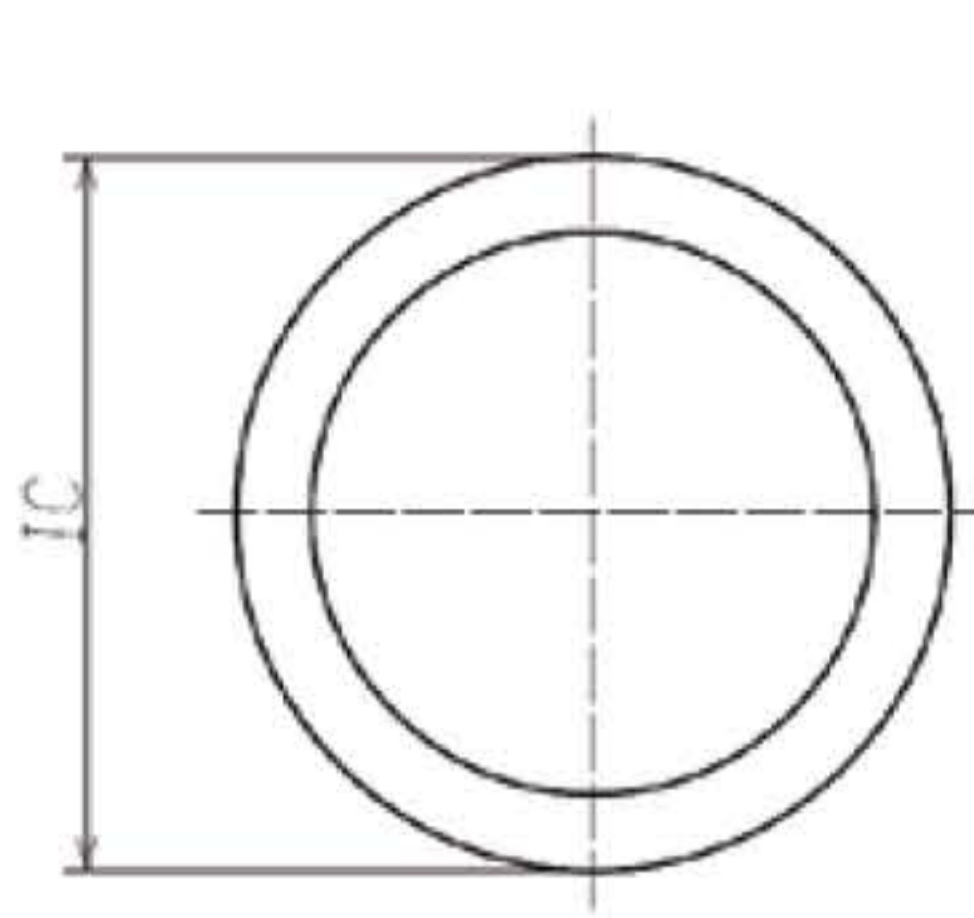

Insert number	Honing code	IC mm	S mm	Silicon Nitride-based Ceramic	
				SX3	SX9
RNGF060300E-HNF	E004	6.35	3.18	●	●
RNGF060400E-HNF	E004	6.35	4.76	●	●
RNGF090400E-HNF	E004	9.525	4.76	●	●
RNGF120400E-HNF	E004	12.7	4.76	●	

JRF Milling Cutter

Instructions for Installing Parts on the JRF Cutter

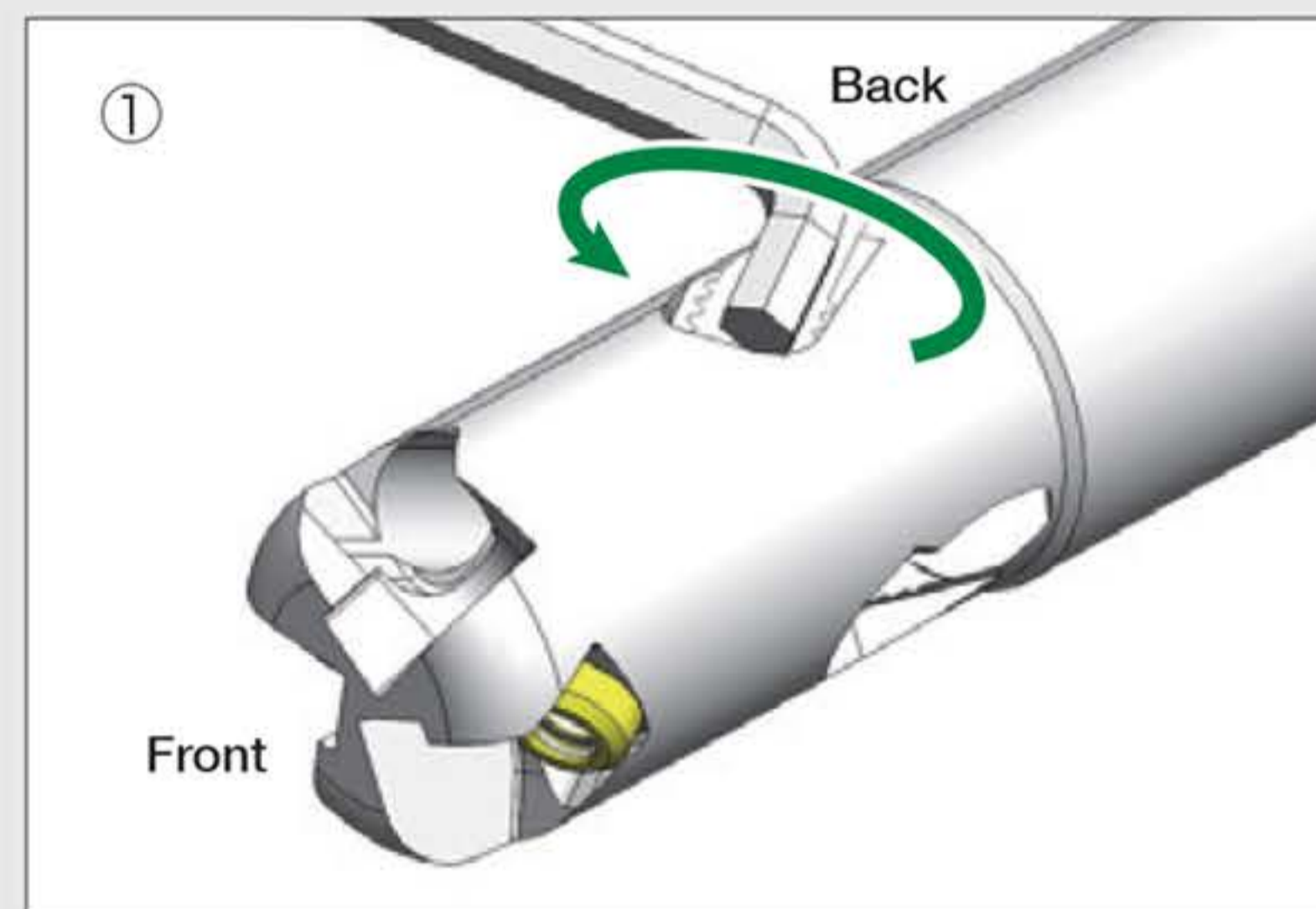
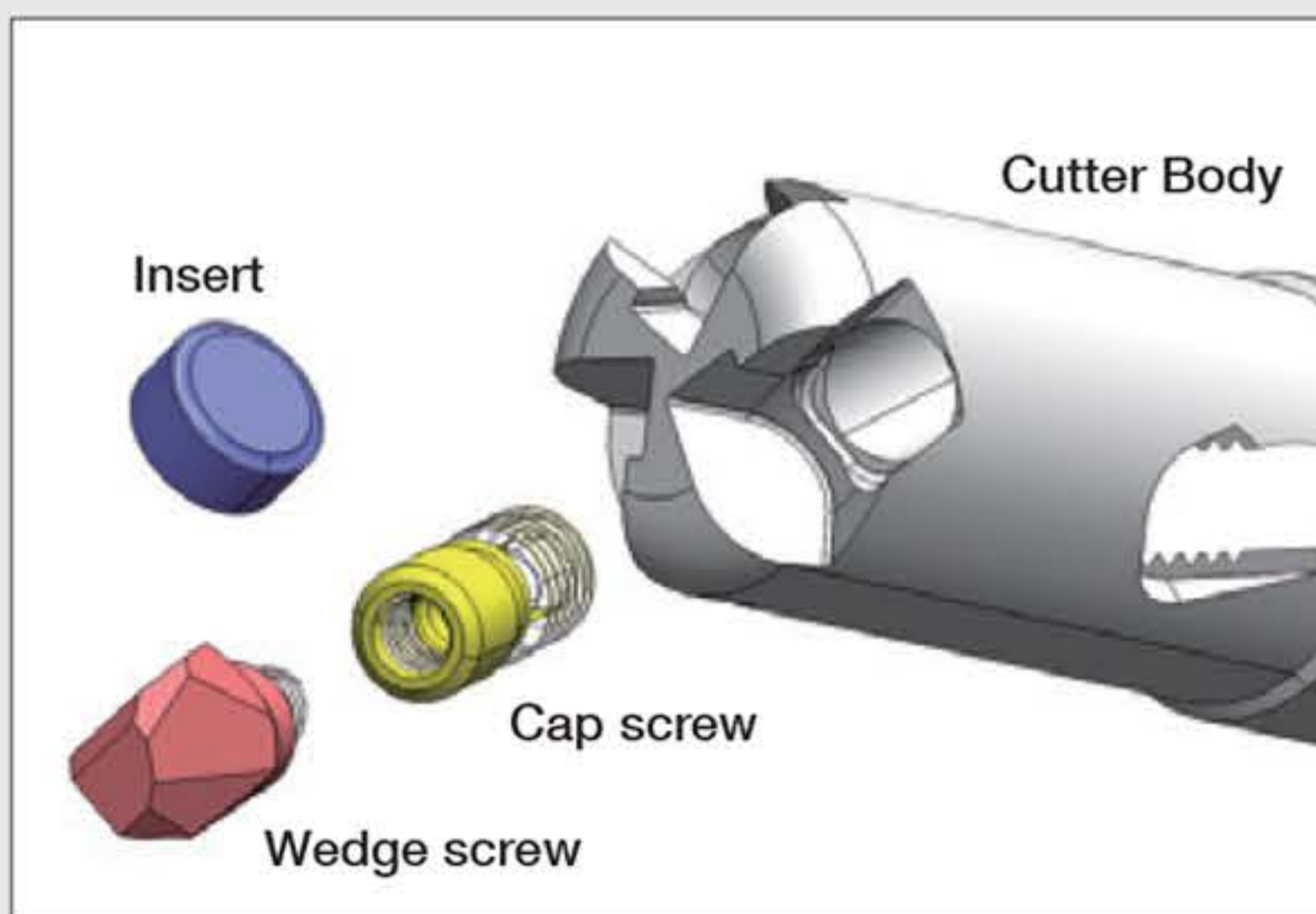

Insert the cap screw from the front and turn it once with a hex wrench inserted from the back

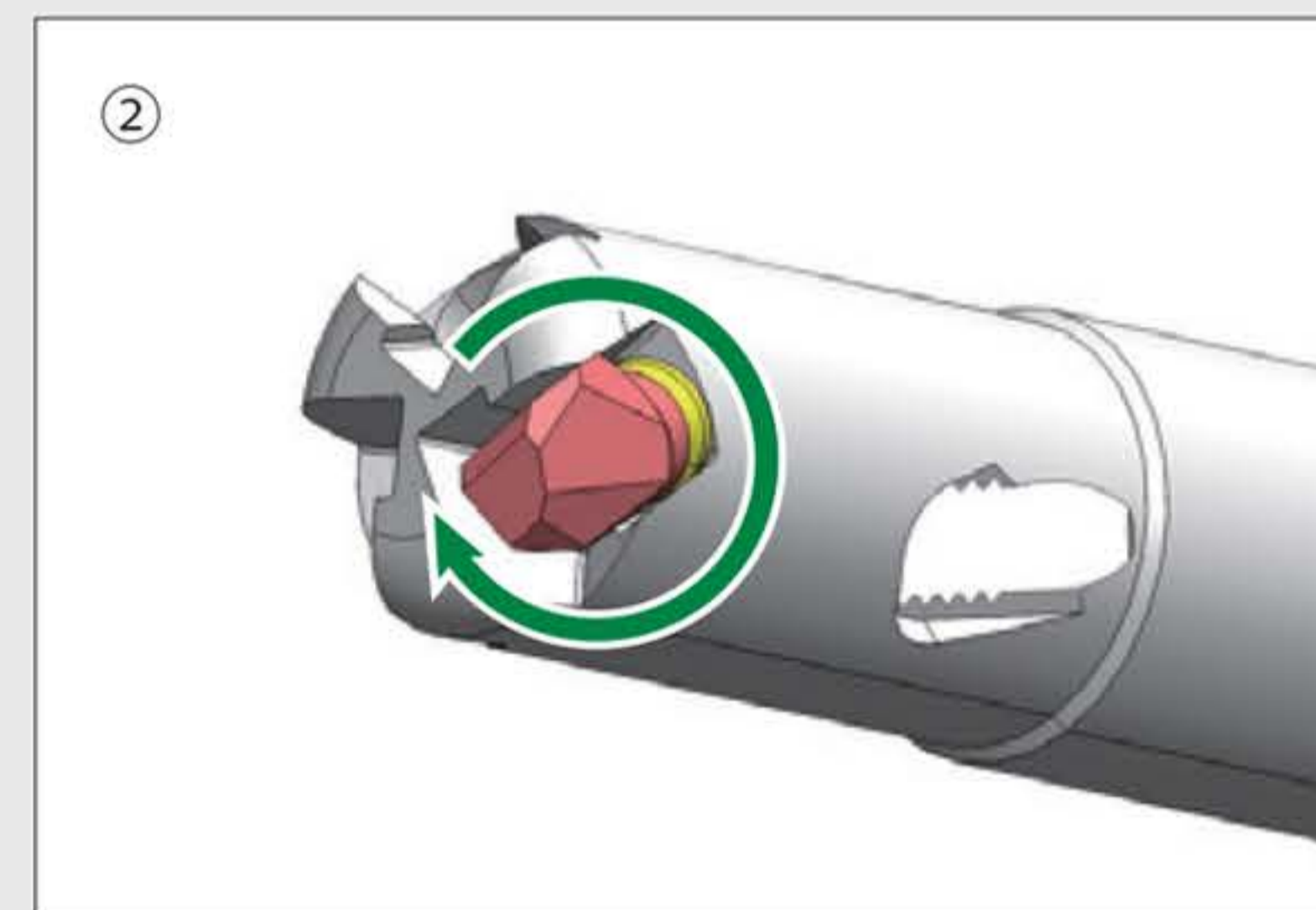

Insert the wedge screw into the cap screw from step 1 and turn it by hand one full rotation.

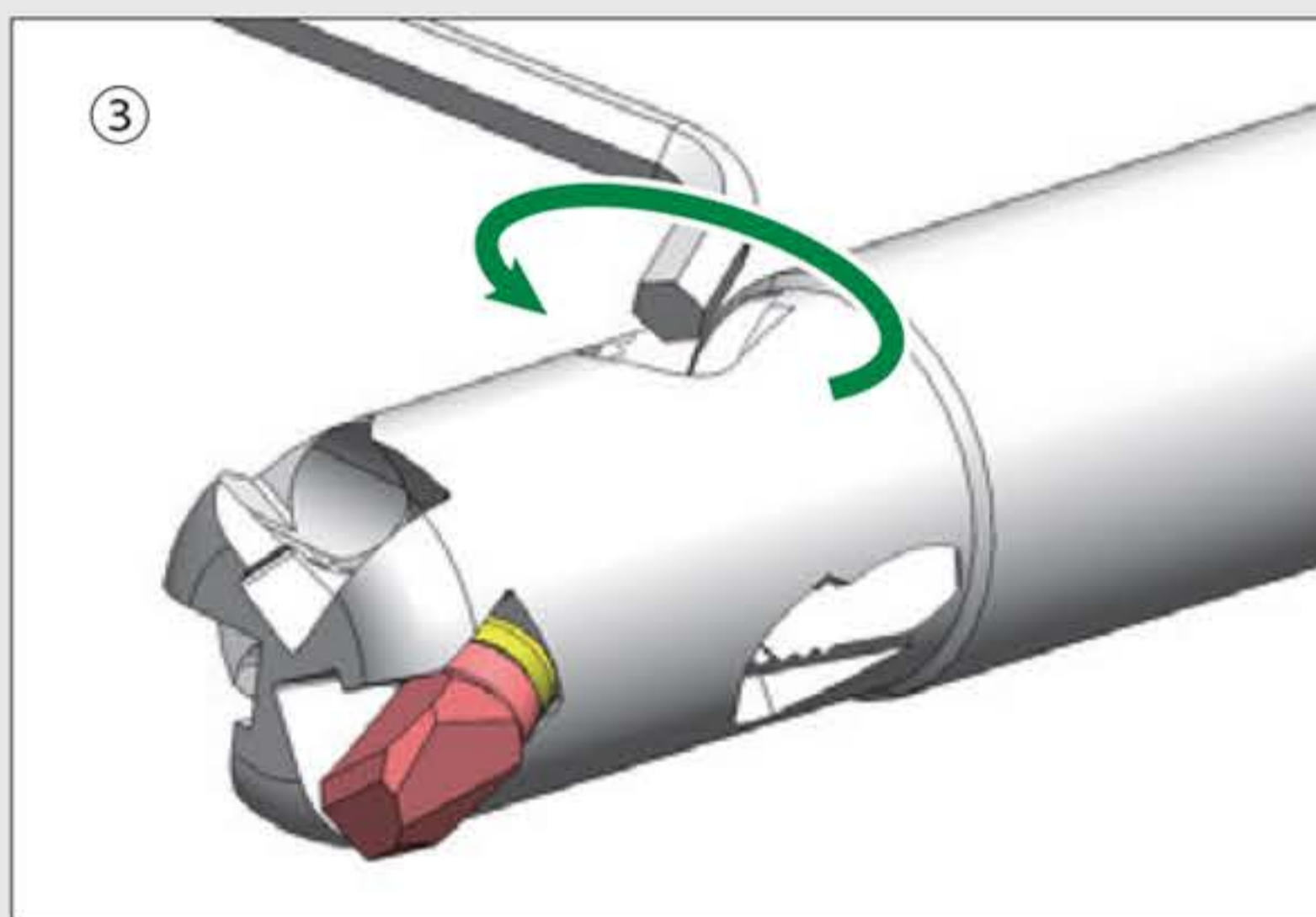

While holding the wedge screw from step 2 by hand, insert a hex wrench from the back and continue turning it until it stops.

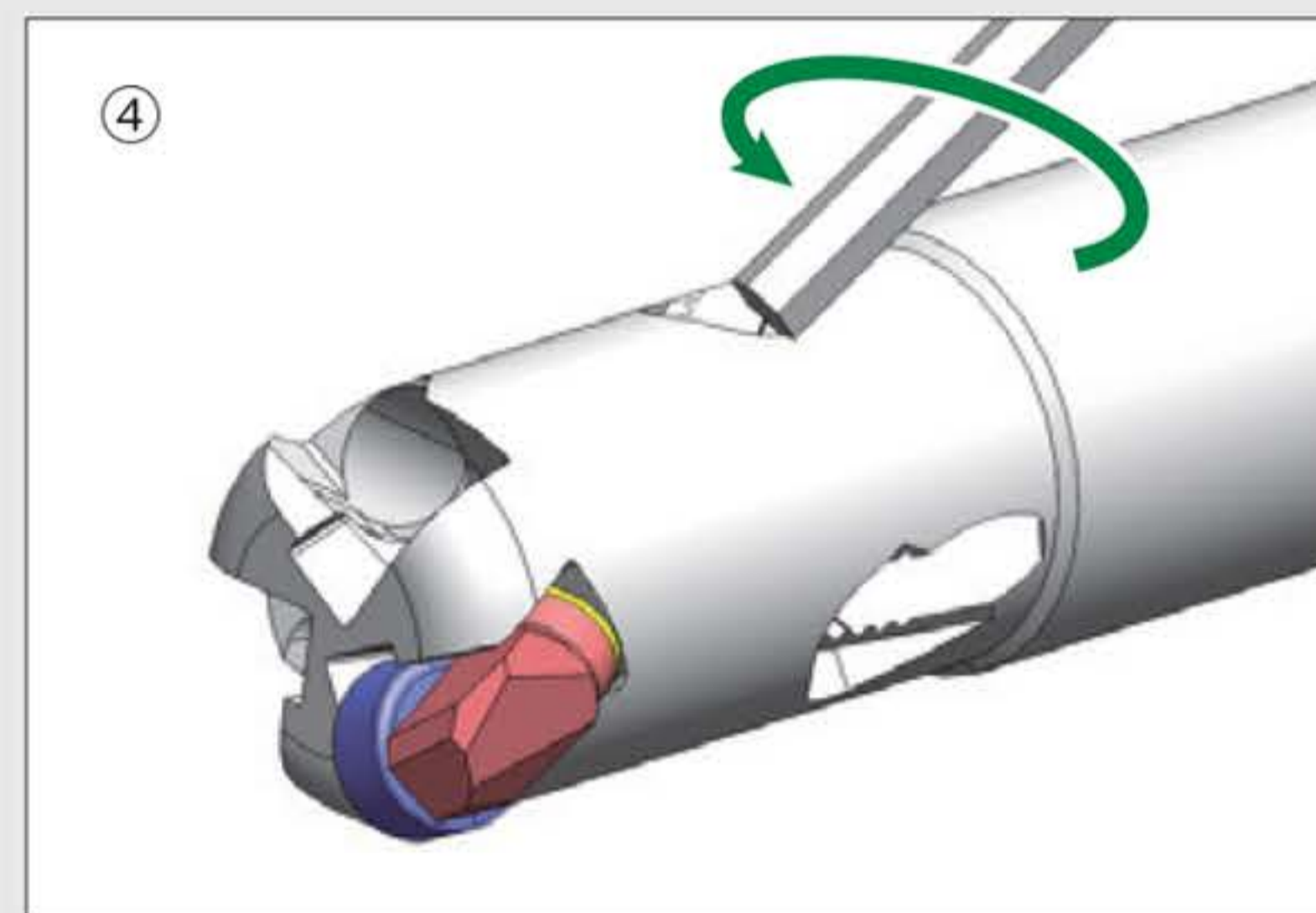

Insert a torque wrench from the back and clamp the insert with the recommended torque value from the table below.



Video Tutorial: How to Install Parts on the JRF Cutter!

Recommended Torque Table

Cutter Number	Recommended Torque	Maximum Torque	Cap screw	Wedge screw
JRFMH016E160R03	1N·m	3N·m	HCS3P050	HWS3P050
JRFIH0625E0625R03				
JRFMH020E200R03				
JRFIH075E075R03				
JRFMH025E250R04				
JRFIH100E100R04				
JRFMH032E320R05				
JRFIH125E125R05	4N·m	6N·m	HCS5P080	HWS5P080
JRFMH025E250R03				
JRFIH100E100R03				
JRFMH032E320R04				
JRFIH125E125R04				
JRFMH032E320R03				
JRFIH125E125R03				

CONTACT US



MEGA TECH METALWORK CO.,LTD (Headquarter)



Tel : 02-943-1591



Fax : 02-943-1592



Line ID : @mgt_metalwork



Email : sales.m@mgtg.co.th



Web : <https://www.mgtg.co.th/>



**17/4 Soi Ramintra 89
Ramintra Khannayao
Bangkok 10230**

