

NEW PRODUCT NEWS

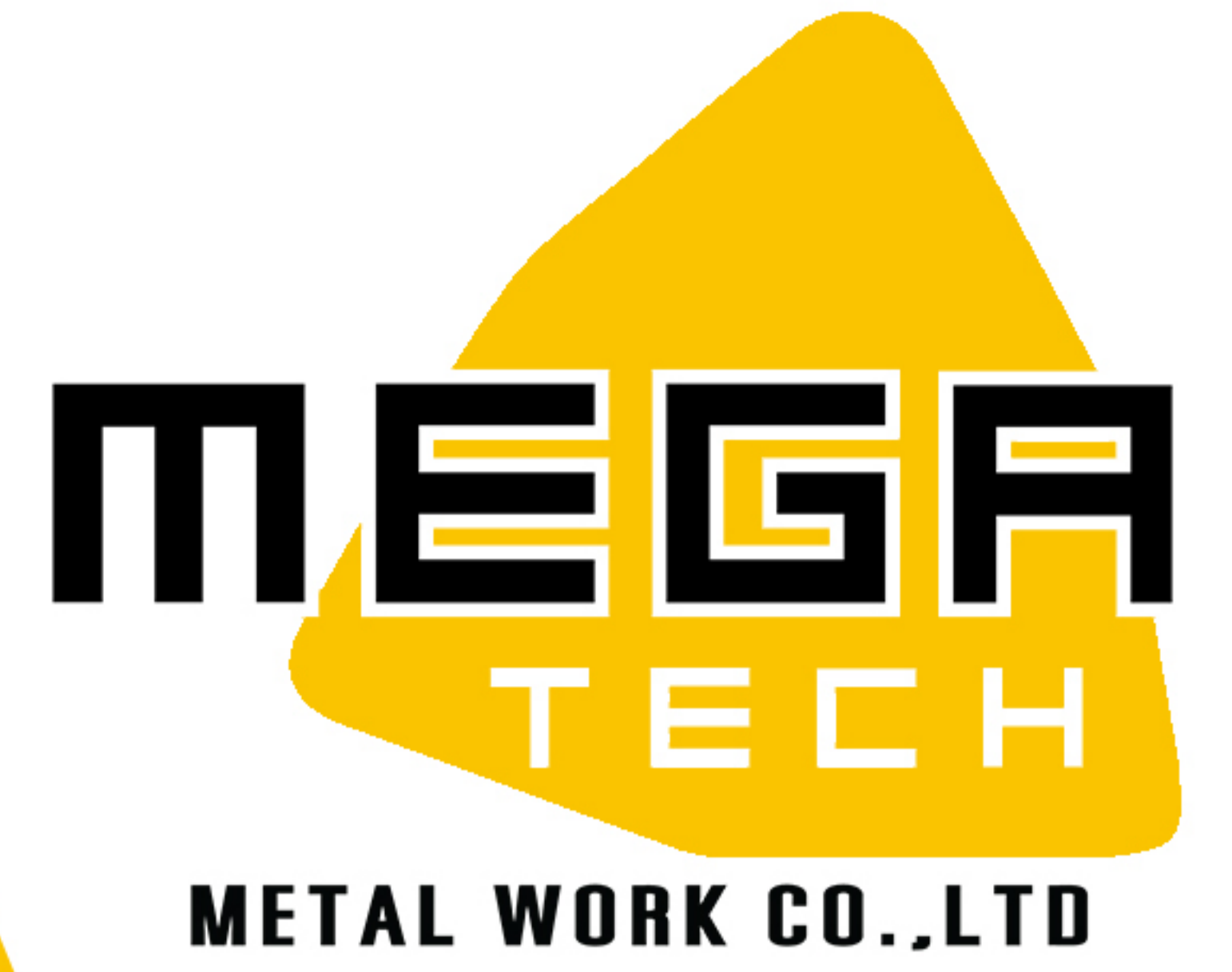

Tungaloy Report No. 504S4-G

Parting off, Grooving, Back turning, Threading Tools

DUO^{JUST}CUT

**NEW INSERTS WITH OPTIMIZED PRESSED-IN
3D CHIPBREAKER FOR BACK TURNING**

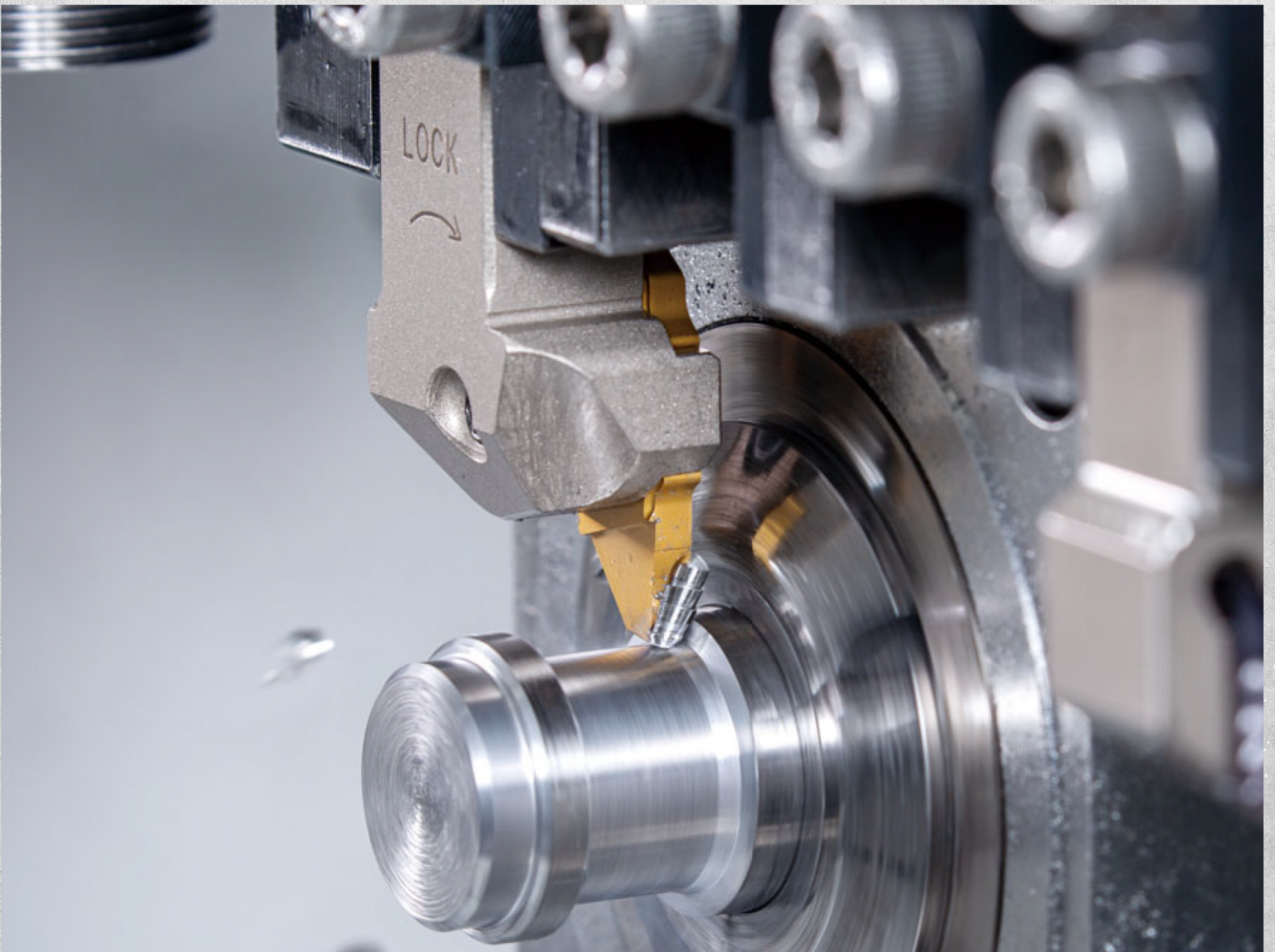

DUOJUST CUT

New DuoJustCut inserts with high rigidity clamping optimized for back turning

Optimized pressed-in 3D chipbreaker

- Eliminates wrapping issues and associated chip related problems
- Wiper edge provides superior surface finish

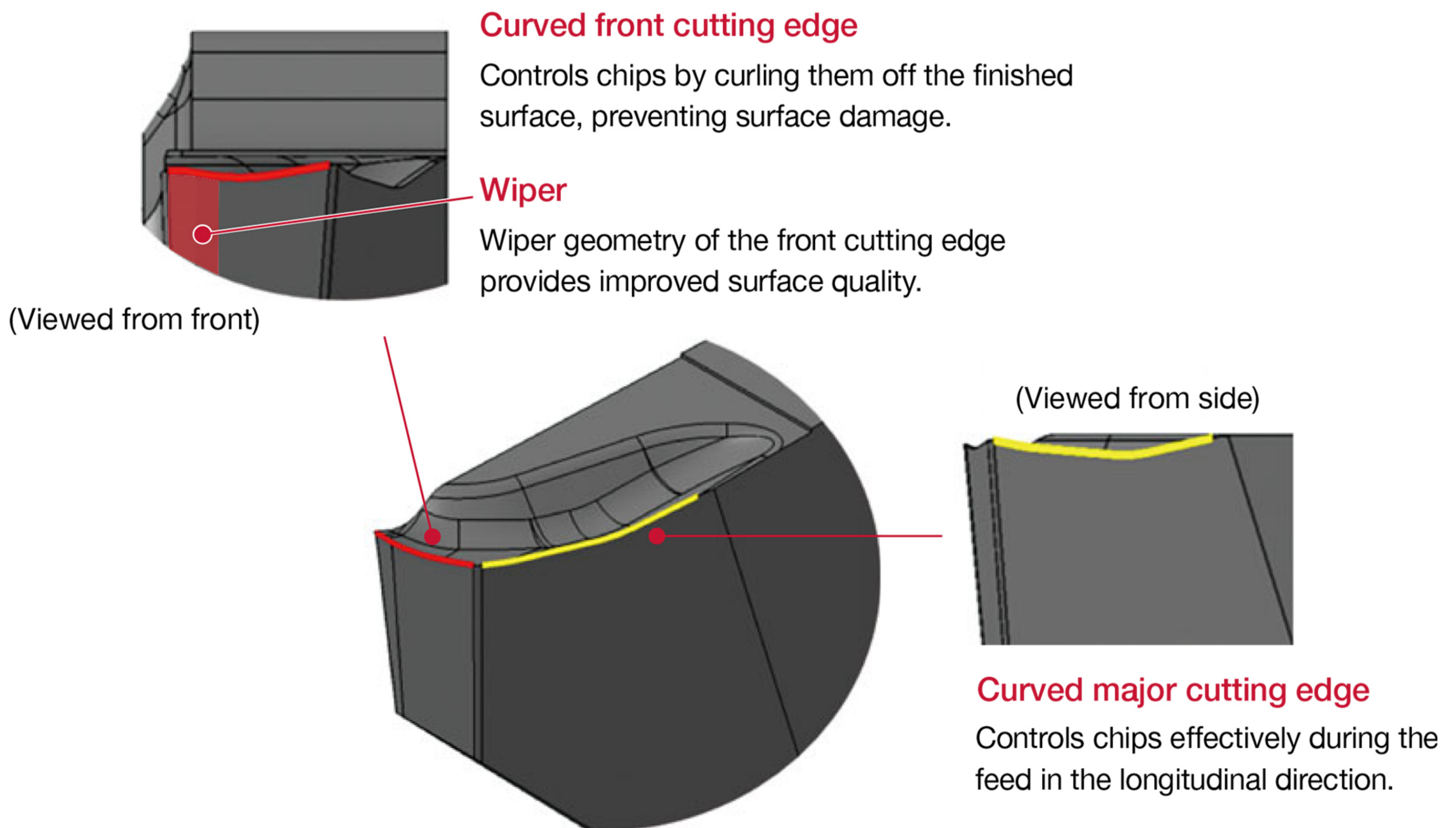

CUTTING PERFORMANCE

Chip control comparison

P C45 / S45C

Toolholder : JSXXR1212X09-CHP
 Insert : JXBM12R72005F SH7025
 Cutting speed : $V_c = 100$ m/min
 Depth of cut : $a_p = 1$ mm
 Coolant : Oil

0.05	0.08	0.1	0.12
Feed: f (mm/rev)			

M X5CrNiMo17-12-3 / SUS316L

Toolholder : JSXXR1212X09-CHP
 Insert : JXBM12R72005F SH7025
 Cutting speed : $V_c = 40$ m/min
 Depth of cut : $a_p = 1$ mm
 Coolant : Oil

0.03	0.05	0.08	0.1
Feed: f (mm/rev)			

■ Surface roughness comparison

M

X5CrNi18-9 / SUS304

Toolholder : JSXXR1212X09-CHP
 Insert : JXBM12R72005F SH7025
 Cutting speed : $V_c = 40$ m/min
 Feed : $f = 0.03$ mm/rev

Depth of cut : $a_p = 3$ mm
 Coolant : Oil
 Machine : Swiss lathe

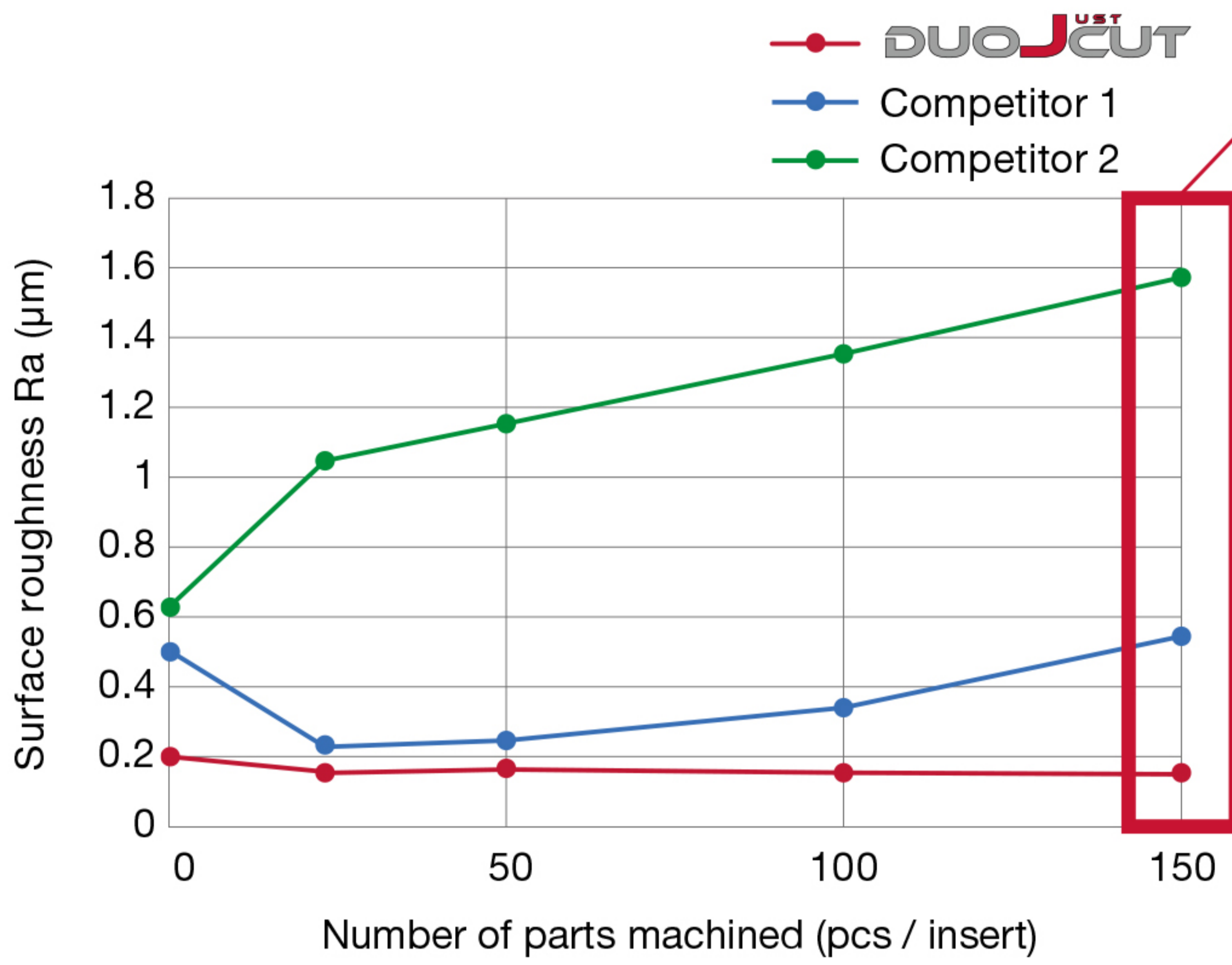

Surface roughness results of the 150th part

	DUOJ CUT	Competitor 1	Competitor 2
Surface finish (1200 times)			
3D profile			
Surface roughness Ra (µm)	0.15	0.53	1.57

Wiper edge provided improved surface roughness

■ INSERTS

JXBM12R (with 3D chipbreaker, sharp edge)

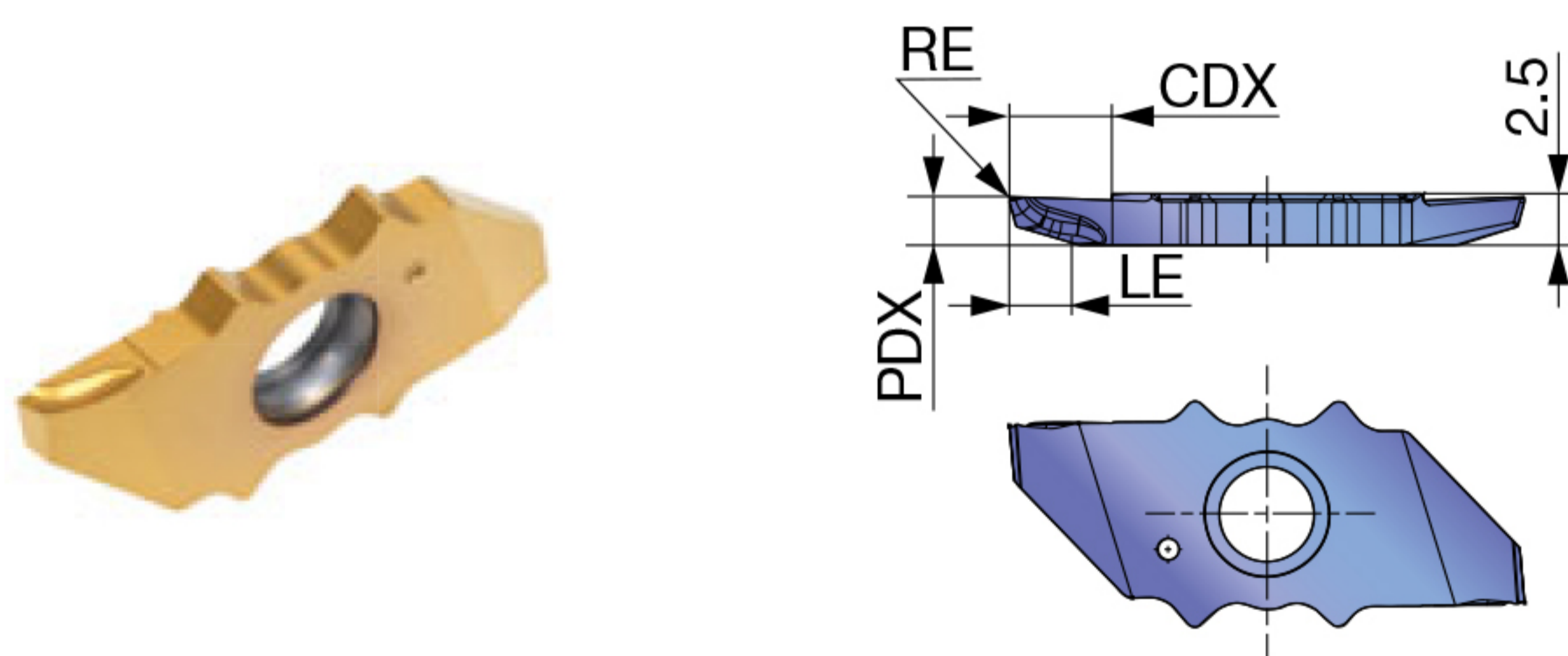

Right-hand (R) shown.

P	Steel	★					
M	Stainless	★					
K	Cast iron	★					
N	Non-ferrous						
S	Superalloys	★					
H	Hard materials						



Designation	HAND	RE	Coated					CDX	LE	PDX
			SH7025							
JXBM12R72005F	R	0.05	●					6	3.5	2.35
JXBM12R72010MF	R	0.08	●					6	3.5	2.35
JXBM12R72020MF	R	0.18	●					6	3.5	2.35

● : New product

STANDARD CUTTING CONDITIONS

ISO	Workpiece materials	Grades	Cutting speed Vc (m/min)	Feed f (mm/rev)
P	Low carbon steels S15C, SS400, etc. C15E4, E275A, etc.	SH7025	50 - 150	0.02 - 0.15
	Carbon steels, Alloy steels S55C, SCM440, etc. C55, 42CrMo4, etc.	SH7025	50 - 150	0.02 - 0.15
	Free cutting steels SUH22, SUH23, etc.	SH7025	50 - 150	0.02 - 0.15
M	Stainless steels SUS304, X5CrNi18-9, etc.	SH7025	30 - 120	0.02 - 0.12
N	Aluminium alloys A5056, A6061, etc.	SH7025	100 - 150	0.02 - 0.15
	Copper alloy C2600, C280C, etc.	SH7025	100 - 150	0.02 - 0.15
S	Titanium alloys Ti-6Al-4V, etc.	SH7025	30 - 80	0.01 - 0.05
	Superalloys Inconel718, etc.	SH7025	30 - 80	0.01 - 0.05

PRACTICAL EXAMPLES

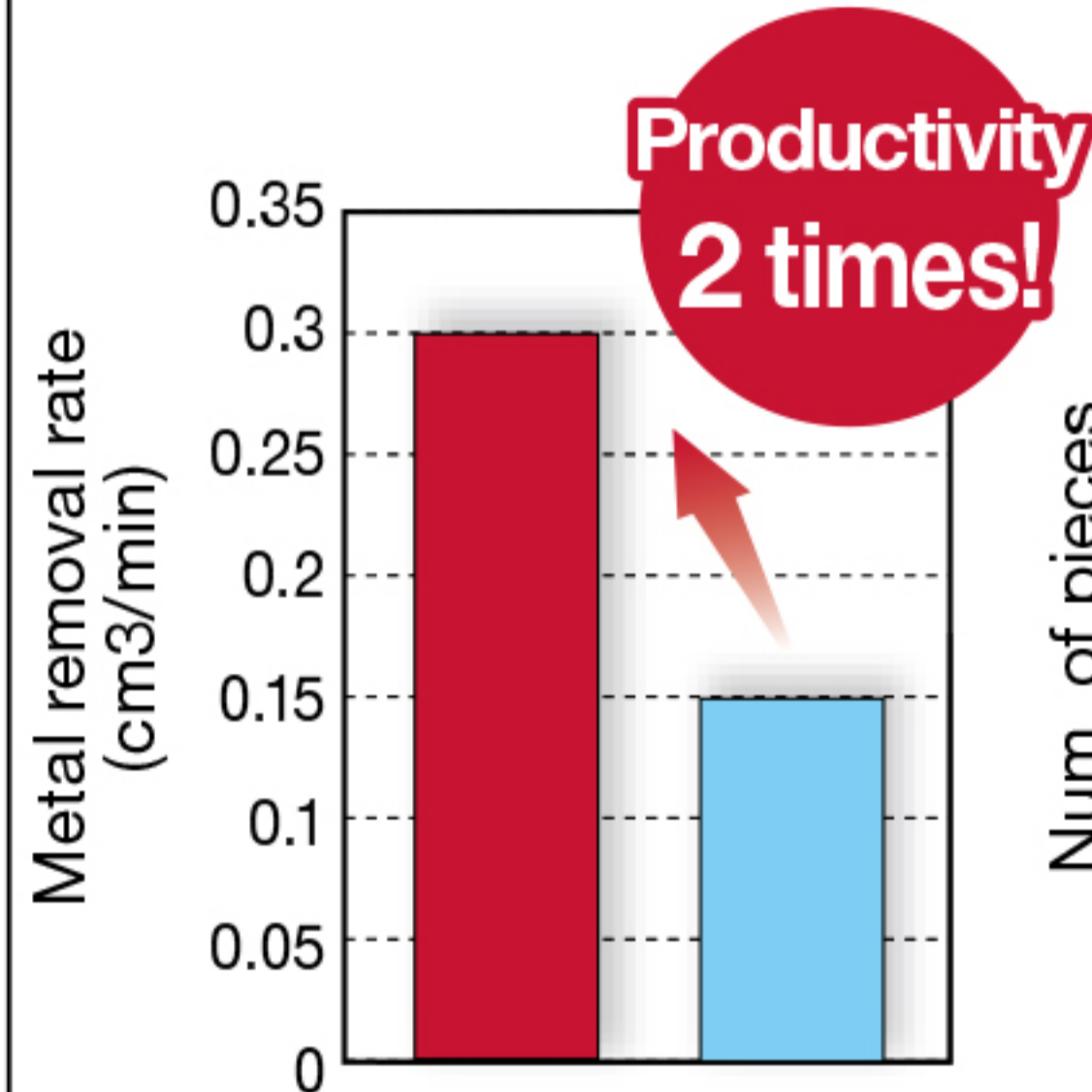
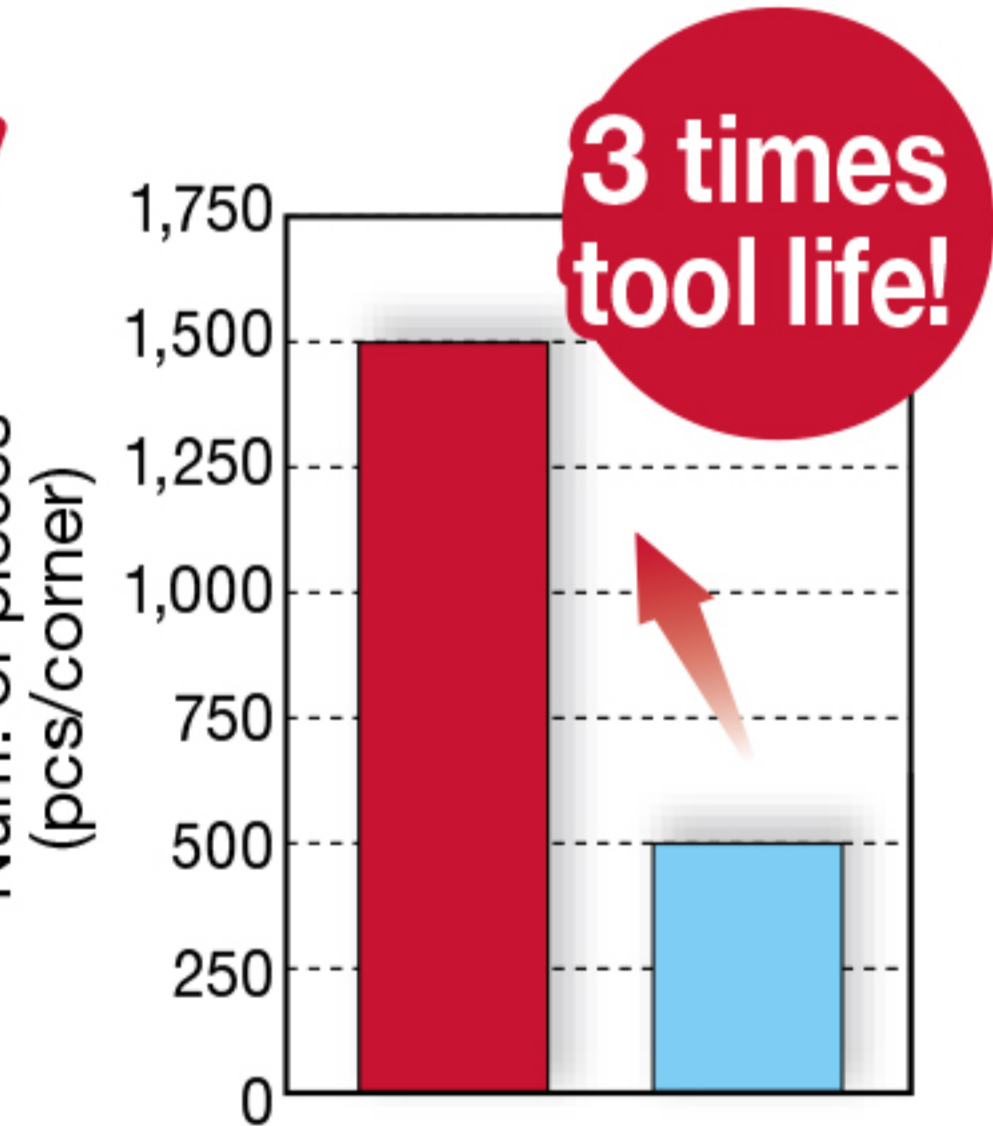
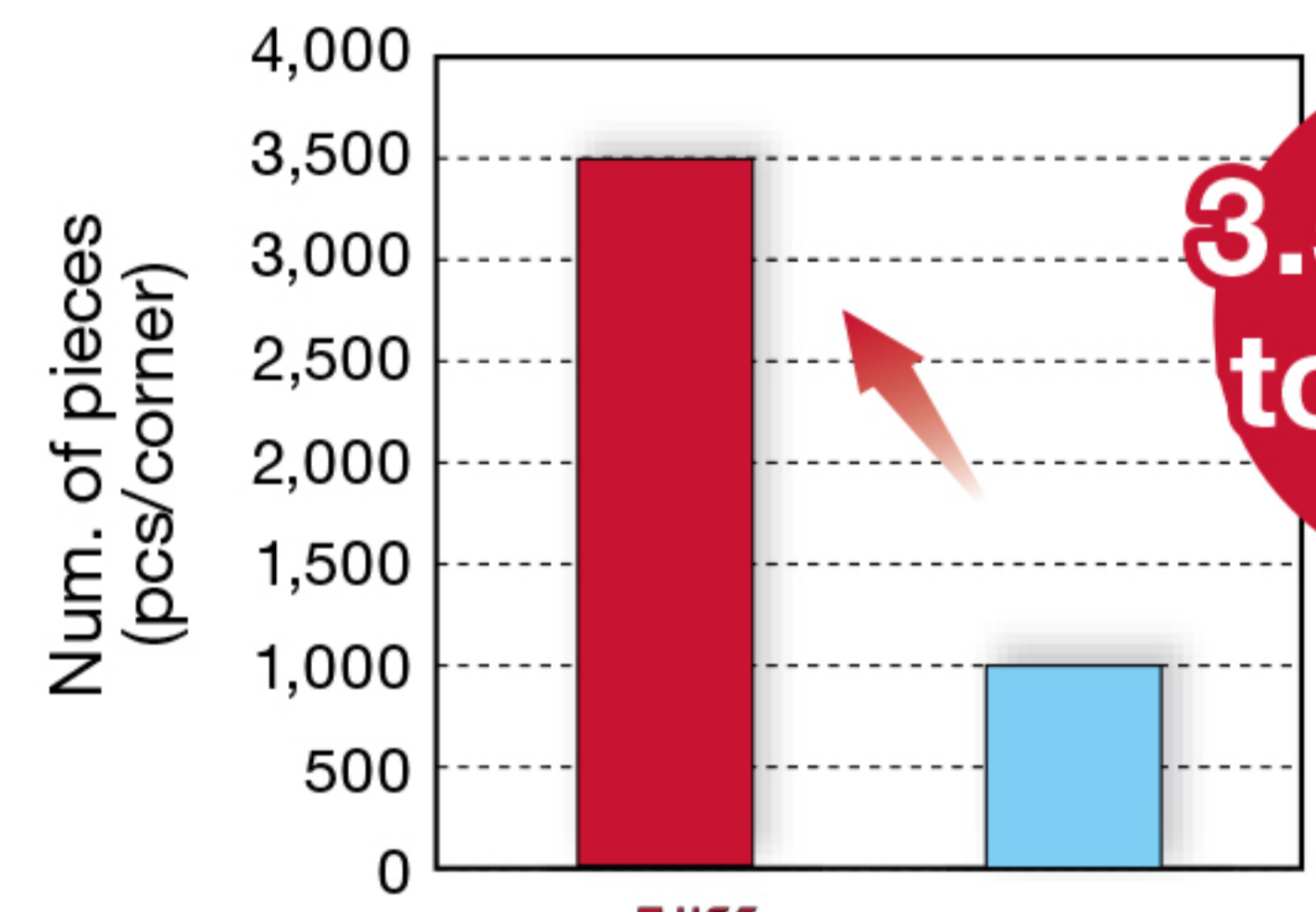
Workpiece type		Dental parts	Valve
Toolholder		JSXXR1212X09	JSXXR1616X09-CHP
Insert		JXBM12R2010MF	JXBM12R72020MF
Grade		SH7025	SH7025
Workpiece material		Ti6Al4V  S	X5CrNi18-9 / SUS304  M
Cutting conditions	Cutting speed: Vc (m/min)	40	100
	Feed : f (mm/rev)	0.015	0.02
	Depth of cut : ap (mm)	0.5	1.3
	Machining	Back turning	Back turning
	Coolant	Oil	Oil
Results		 <p>Productivity 2 times!</p>  <p>3 times tool life!</p> <p>DuoJustCut provided improved surface quality and higher machining efficiency thanks to its wiper design. M.R.R. has doubled, and insert tool life has tripled.</p>	 <p>3.5 times tool life!</p> <p>DuoJustCut SH7025 grade insert provided better surface roughness and 3.5 times longer tool life.</p>

CONTACT US



MEGA TECH METALWORK CO.,LTD (Headquarter)



Tel : 02-943-1591



Fax : 02-943-1592



Line ID : @mgt_metalwork



Email : sales.m@mgtg.co.th



Web : <https://www.mgtg.co.th/>



**17/4 Soi Ramintra 89
Ramintra Khannayao
Bangkok 10230**

