

NEW PRODUCT NEWS

**MEGA
TECH**
METAL WORK CO.,LTD

Taegutec Milling Line

CHASE & SPEED

FACING & HIGH FEED

**NEW ML CHIP FORMER
FOR SQKU 11 AND 14 INSERTS**



ADVANCECUTTING
TaeguTec

TaeguTec
Member IMC Group

KEY POINT

TaeguTec introduces a new ML chip former for the CHASE-8-SFEED's SQKU insert line.

The high-performance and high-productivity CHASE-8-SFEED milling line, targeting the medium and rough machining market, has introduced a new ML chip former to address a variety of material machining needs.

With a sharp cutting edge suitable for long chip applications or tough ISO M material machining, this ML chip former provides even better stability due to its smoother cutting, resulting in higher productivity.

For detailed information about the CHSE-8-SFEED line, refer to our previous NPN.

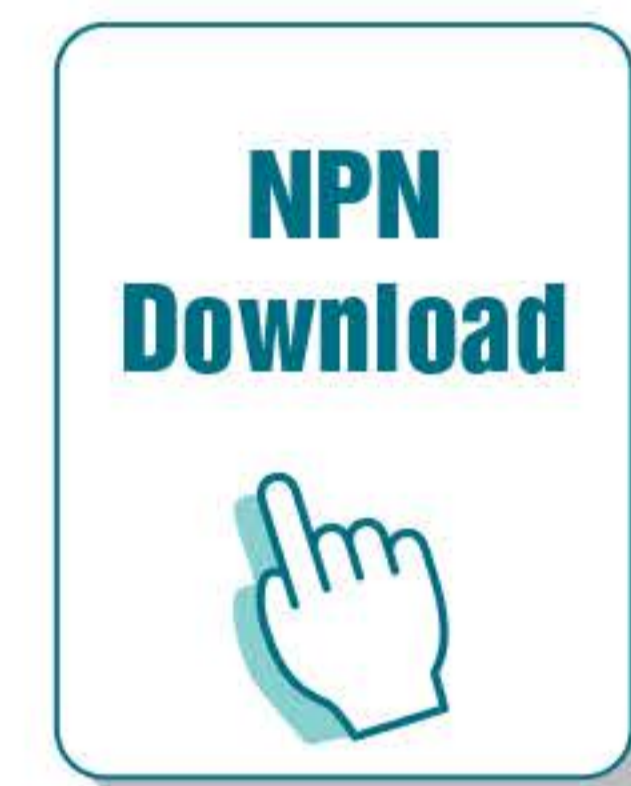
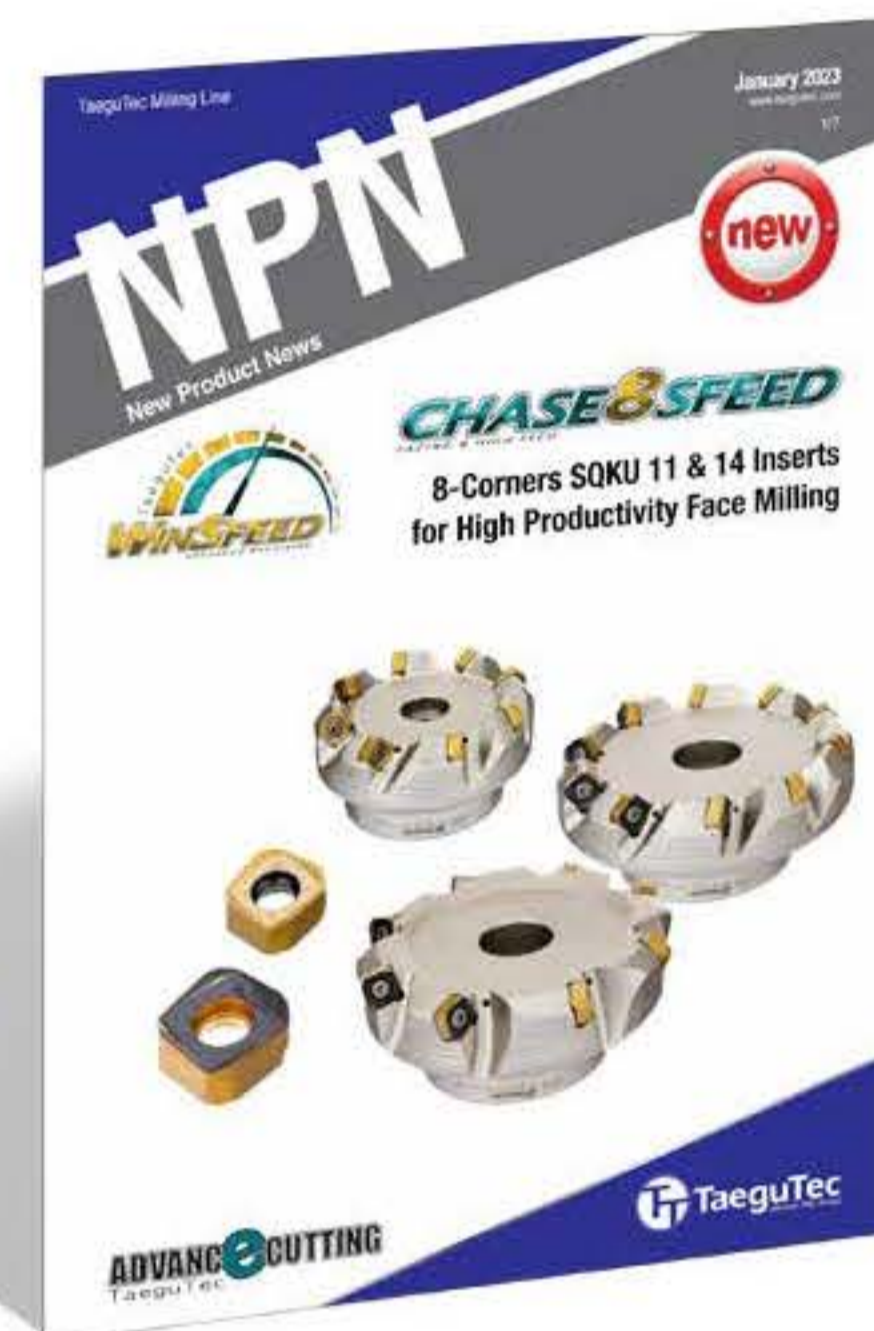

ML chip former with sharp cutting edge

Current M chip former	New ML chip former

SQKU 11/14



Inserts

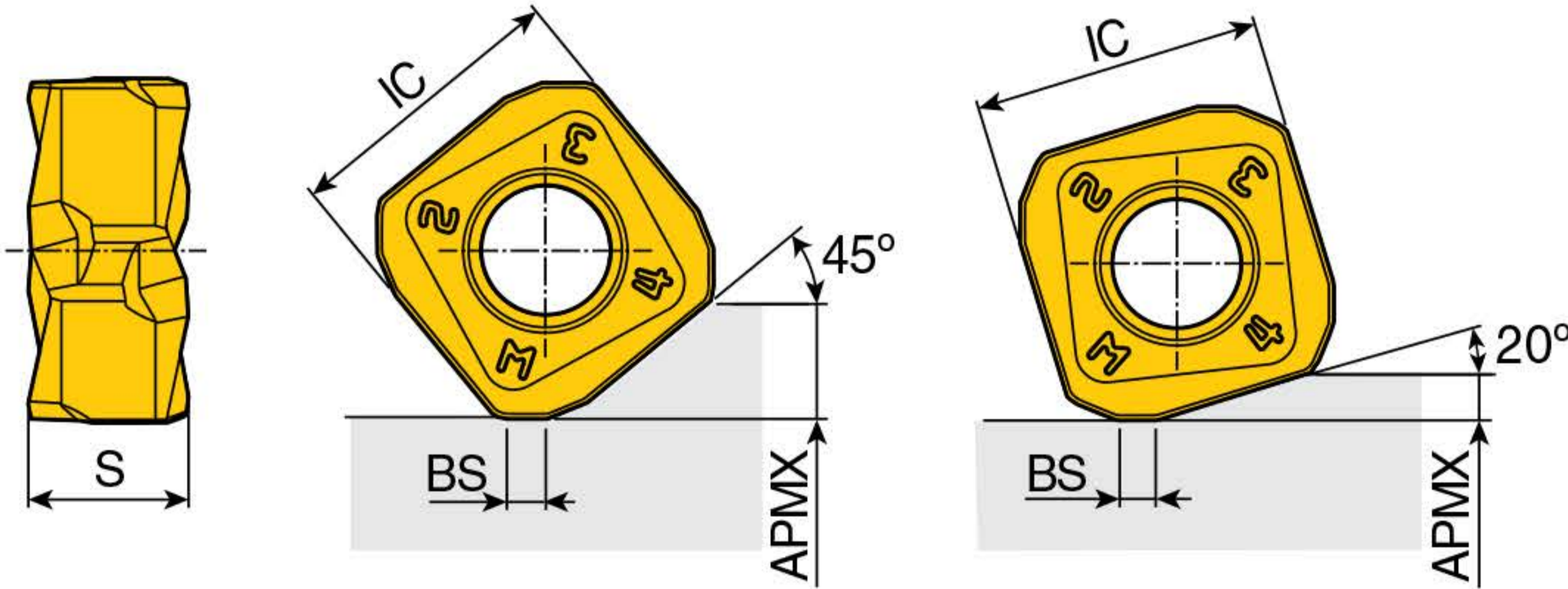

Size	Dimension (mm)					
	IC	S	APMX	BS		
11(45°)	11.2	6.3	4.2	1.9		
11(20°)	11.2	6.3	1.8	1.0		
14(45°)	14.5	7.8	6.0	2.0		
14(20°)	14.5	7.8	2.5	1.6		

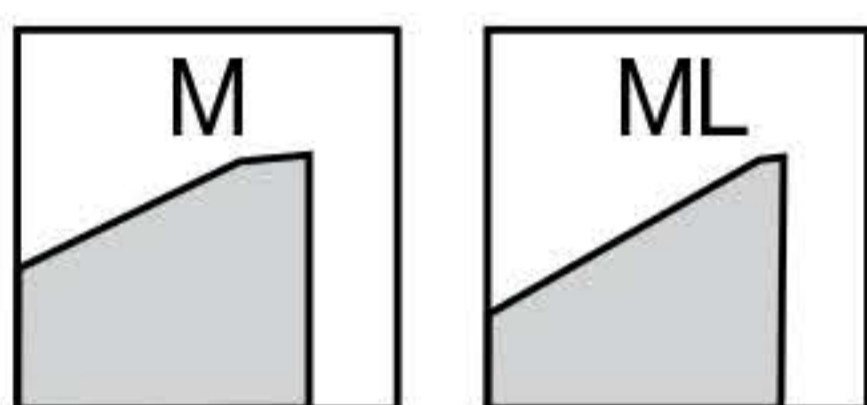

Insert	Designation	Recommended machining conditions		Coated							Uncoated				
		ap (mm)	Feed (mm/tooth)	TT9080	TT9030	TT8080	TT8020	TT8525B	TT7080	TT7515	TT6080	TT3535	TT2510	K10	
	SQKU 1105 ANR-M(45°)	1.0-4.0	0.25-0.10	●				●		●	●				
	1105 ANR-M(20°)	0.2-1.5	1.50-0.30	●				●		●	●				
	1406 ANR-M(45°)	2.0-6.0	0.30-0.10	●				●		●	●				
	1406 ANR-M(20°)	0.3-2.0	2.30-0.40	●				●		●	●				
	SQKU 1105 ANR-ML(45°) new	1.0-4.0	0.25-0.10	●		●					●				
	1105 ANR-ML(20°) new	0.2-1.5	1.00-0.30	●		●					●				
	1406 ANR-ML(45°) new	2.0-6.0	0.30-0.10	●		●					●				
	1406 ANR-ML(20°) new	0.3-2.0	1.30-0.40	●		●					●				

●: Standard items

CONTACT US



MEGA TECH METALWORK CO.,LTD (Headquarter)



Tel : 02-943-1591



Fax : 02-943-1592



Line ID : @mgt_metalwork



Email : sales.m@mgtg.co.th



Web : <https://www.mgtg.co.th/>



**17/4 Soi Ramintra 89
Ramintra Khannayao
Bangkok 10230**

