

NEW PRODUCT NEWS



Taegutec Hole Making Line

WINDRILL

ADVANCED MACHINING



**HEAD CHANGEABLE LINE
FOR SMALL DIAMETER DRILLING**



KEY POINT

TaeguTec introduces an interchangeable drill head line for small diameter hole-making.

Introducing the head-changeable WIN-DRILL line with a unique cutting edge design that improves productivity as well as reduces the cost for small hole applications.

The replaceable head design of the new WIN-DRILL products, which are available in 0.1 mm increments between 4-5.9 mm head diameters, eliminates the need for extra set-up time and increases productivity compared to the solid carbide drill option currently available. These features effectively make the WIN-DRILL family the innovative small-diameter hole machining solution.

For further information, please contact the product manager.

Features

- Head-changeable drills for small diameter holes
- Drill Diameter range: 4-5.9 mm (0.1 mm increments)
- Available in two holder depths: 3xD and 5xD
- Shanks are compatible with a wide range of diameter heads
- Excellent machining performance and high productivity
- No set-up time and no head change offsetting required

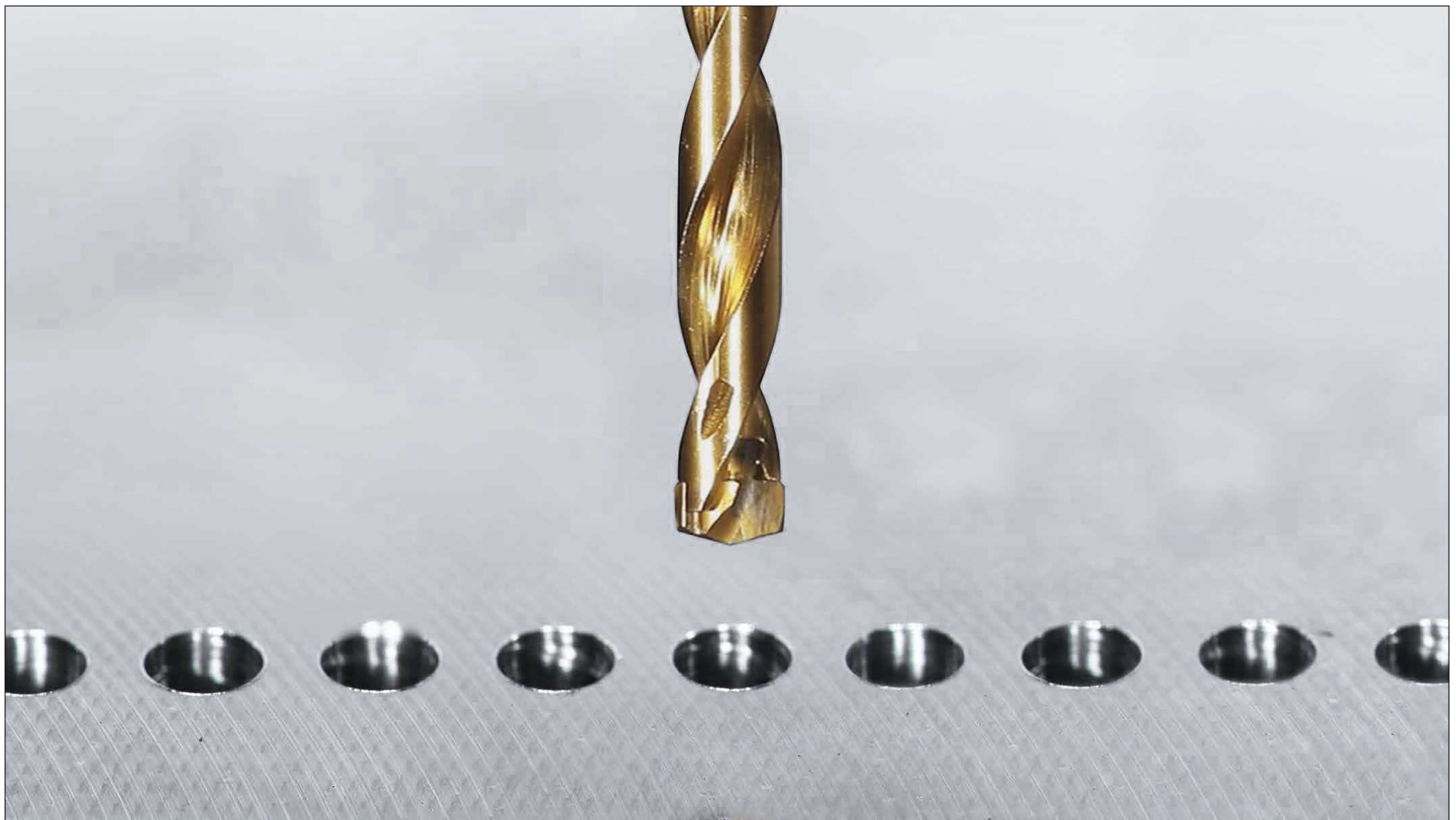

Taegutec Hole Making Line

- Head replacement eliminates tool setting after regrinding (which can cause length errors).
 - Machining downtime is minimized

new WINDRILL
ADVANCED MACHINING

Solid carbide drills

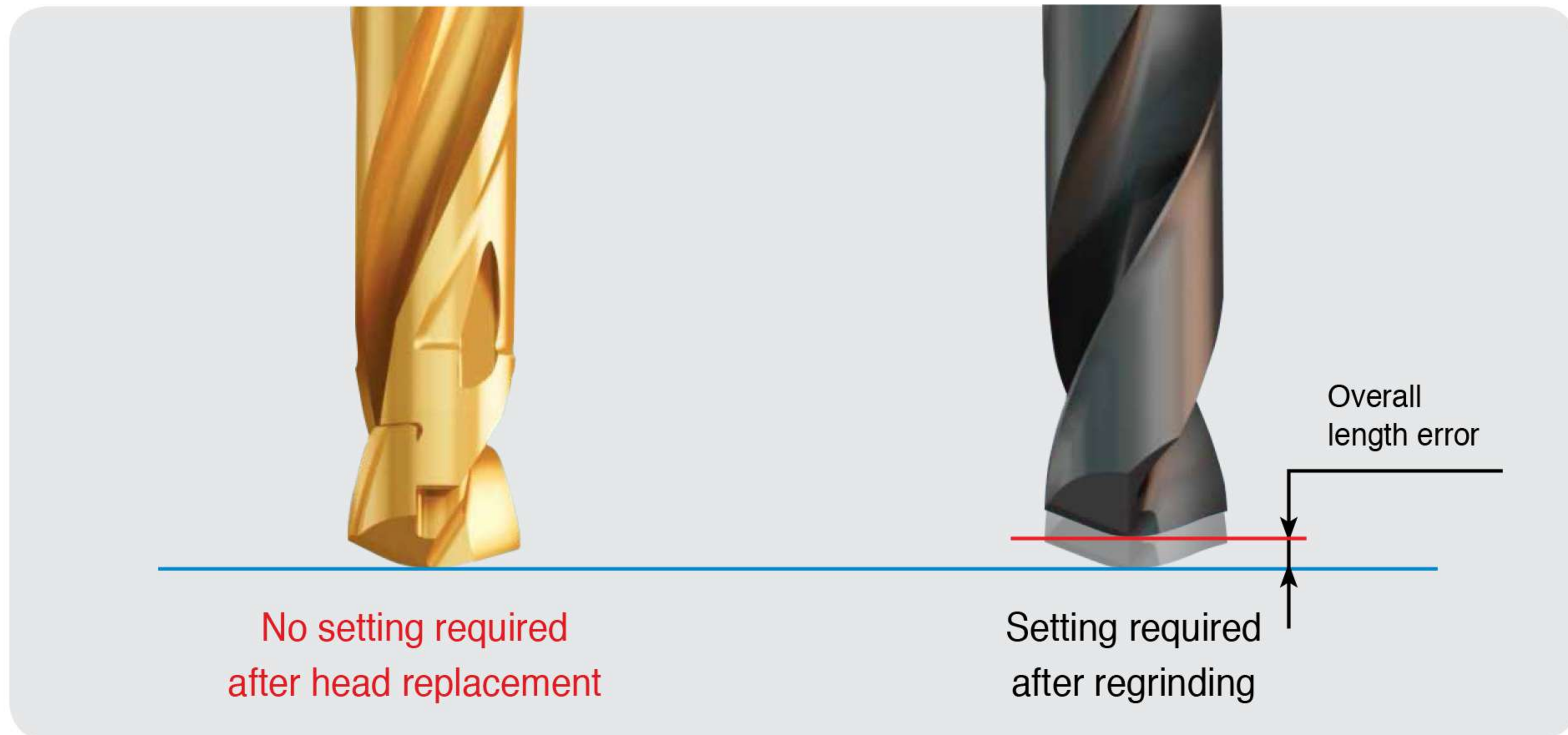

Packaging Details

For convenient indexing of the smaller sized WIN-DRILL products, the head is assembled with the clamping key and a user guide is also enclosed.



Taegutec Hole Making Line

Drilling head mounting procedure

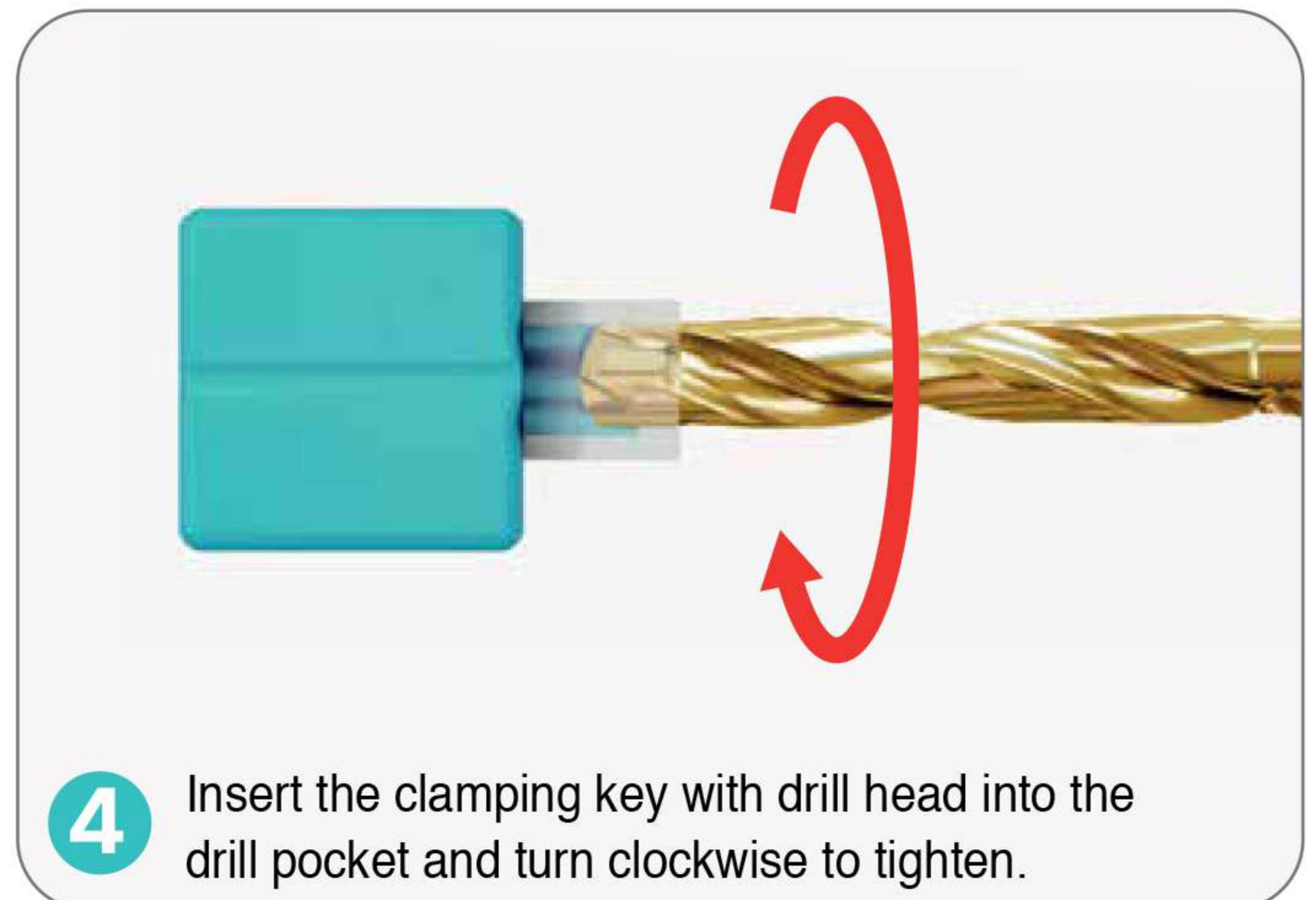
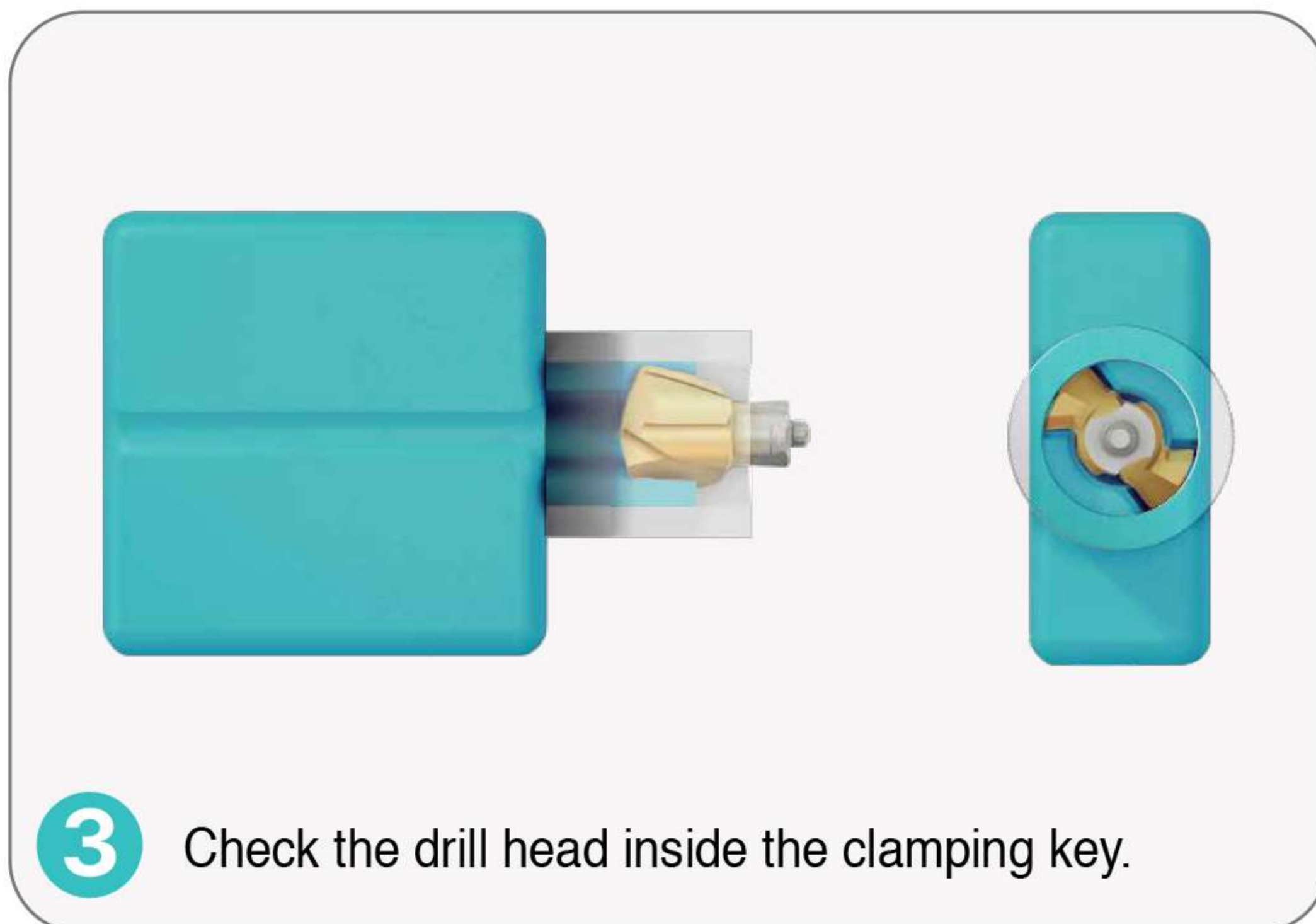
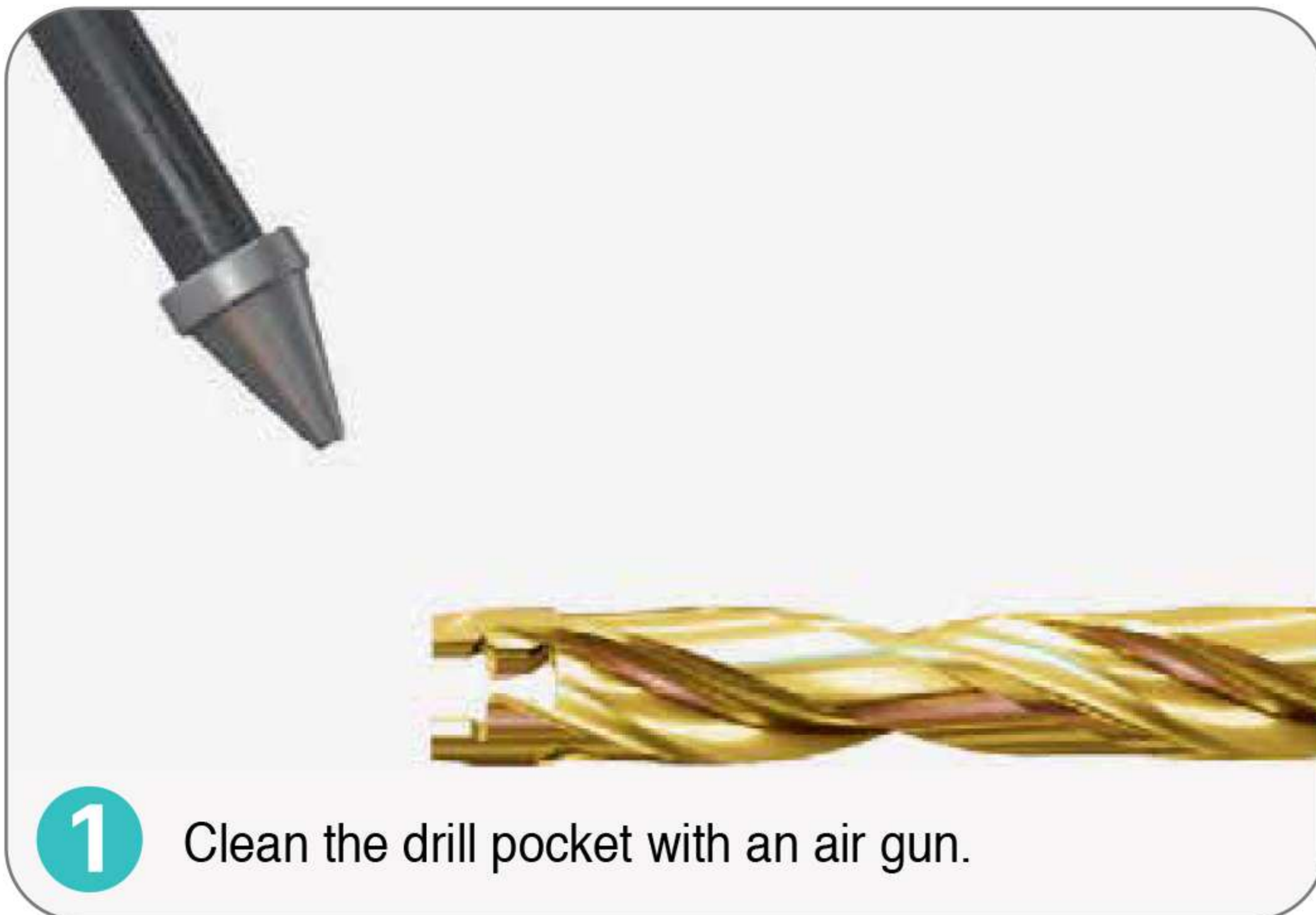

TCD...-3D



Head changeable drill holders - Cylindrical type shank



- Drilling depth: 3xdiameter

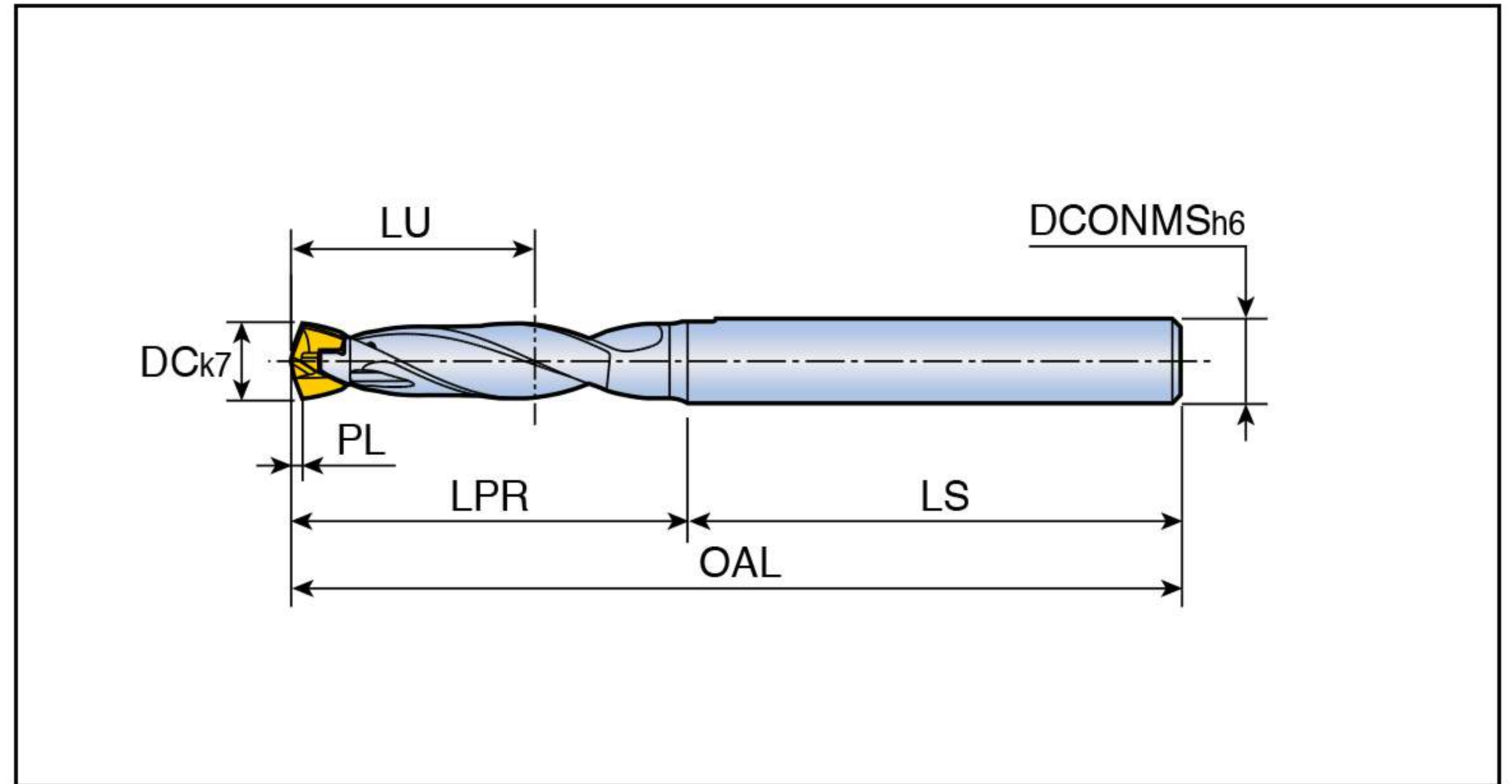

Designation	Dimension (mm)							Clamping key
	DC	DCONMS	LU	LPR	LS	PL	SSC	
TCD 040-044-06A0-3D	4.0-4.4	6	13	22.7	35	0.62	4	K TCD D040-D049
045-049-06A0-3D	4.5-4.9	6	14	24.7	35	0.66	4.5	K TCD D040-D049
050-054-06A0-3D	5.0-5.4	6	16	26.3	35	0.73	5	K TCD D050-D059
055-059-06A0-3D	5.5-5.9	6	17	28.2	35	0.81	5.5	K TCD D050-D059

- ▶ OAL = LPR+LS
- ▶ SSC: Seat size code

TCD...-5D



Head changeable drill holders - Cylindrical type shank



- Drilling depth: 5xdiameter

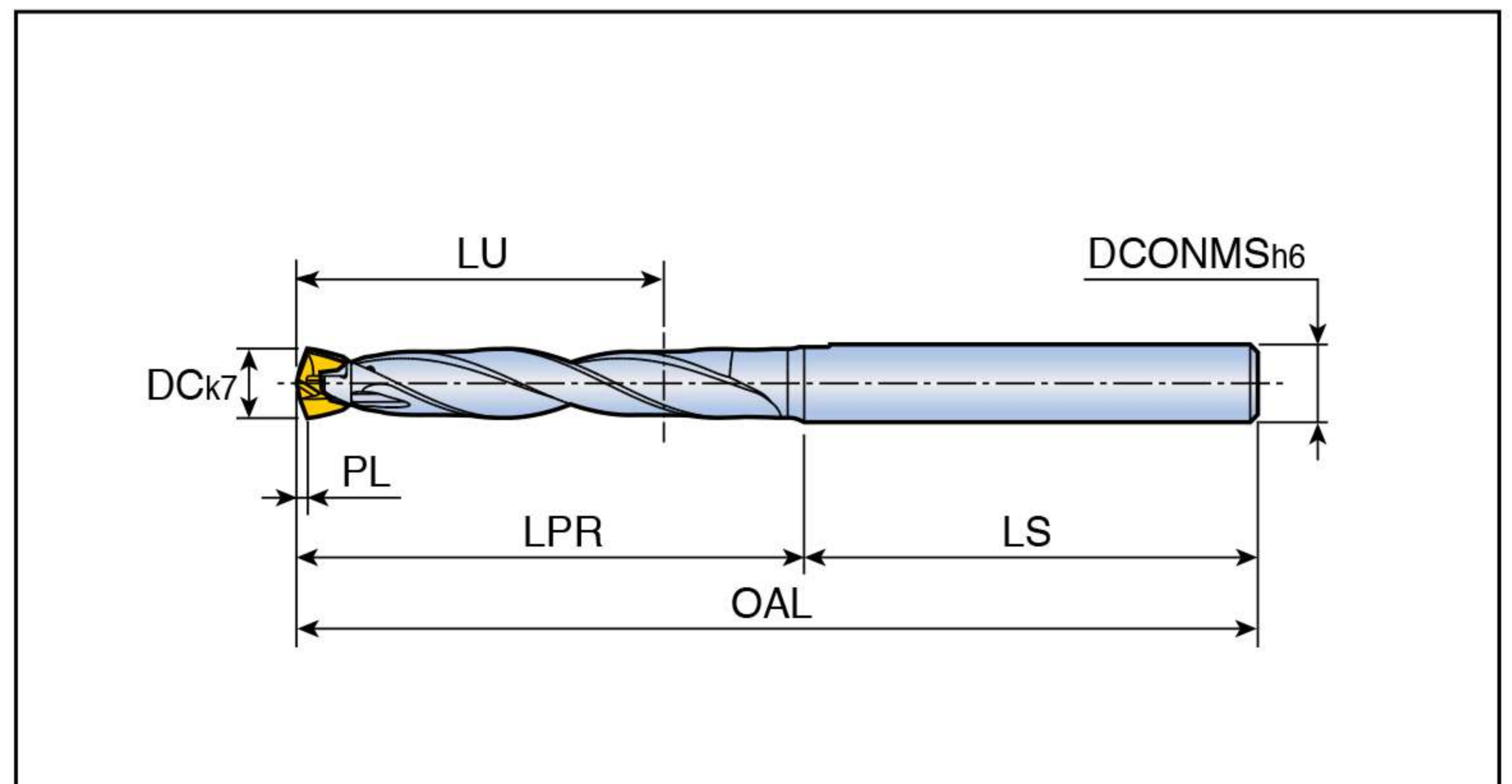

Designation	Dimension (mm)							Clamping key
	DC	DCONMS	LU	LPR	LS	PL	SSC	
TCD 040-044-06A0-5D	4.0-4.4	6	21	30.7	35	0.62	4	K TCD D040-D049
045-049-06A0-5D	4.5-4.9	6	23	33.7	35	0.66	4.5	K TCD D040-D049
050-054-06A0-5D	5.0-5.4	6	26	36.3	35	0.73	5	K TCD D050-D059
055-059-06A0-5D	5.5-5.9	6	28	39.2	35	0.81	5.5	K TCD D050-D059

- ▶ OAL = LPR+LS
- ▶ SSC: Seat size code

TCD...-P



Drill heads

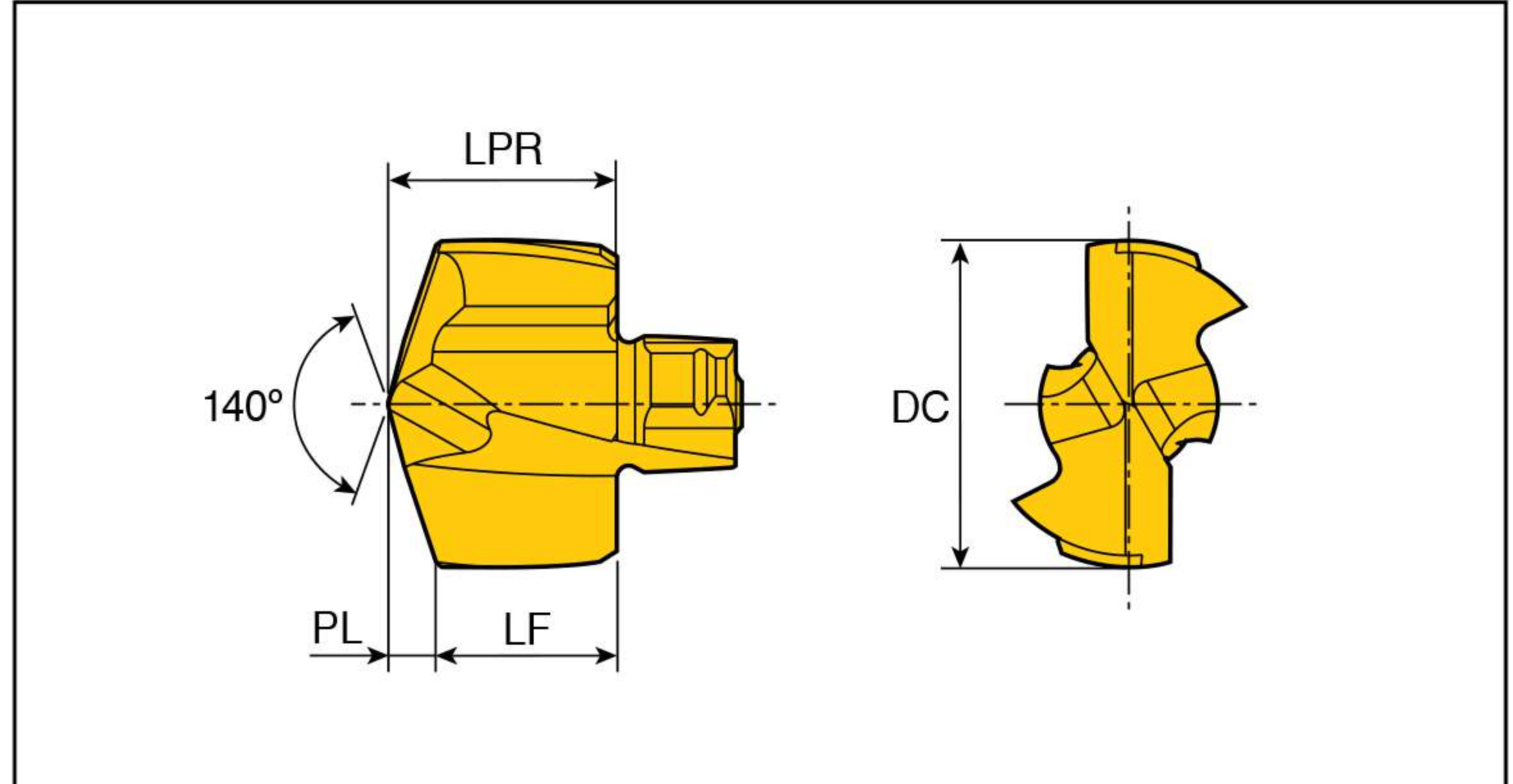

Designation	Dimension (mm)					Grade TT9080
	DC	LPR	PL	LF	SSC	
TCD- 040-P	4.0	3.10	0.62	2.48	4	●
041-P	4.1	3.10	0.64	2.46	4	●
042-P	4.2	3.10	0.66	2.44	4	●
043-P	4.3	3.10	0.67	2.43	4	●
044-P	4.4	3.10	0.69	2.41	4	●
045-P	4.5	3.55	0.66	2.89	4.5	●
046-P	4.6	3.55	0.68	2.87	4.5	●
047-P	4.7	3.55	0.70	2.85	4.5	●
048-P	4.8	3.55	0.71	2.84	4.5	●
049-P	4.9	3.55	0.73	2.82	4.5	●
050-P	5.0	3.70	0.73	2.97	5	●
051-P	5.1	3.70	0.75	2.95	5	●
052-P	5.2	3.70	0.77	2.93	5	●
053-P	5.3	3.70	0.78	2.92	5	●
054-P	5.4	3.70	0.80	2.90	5	●
055-P	5.5	3.85	0.80	3.05	5.5	●
056-P	5.6	3.85	0.82	3.03	5.5	●
057-P	5.7	3.85	0.84	3.01	5.5	●
058-P	5.8	3.85	0.85	3.00	5.5	●
059-P	5.9	3.85	0.87	2.98	5.5	●

▶ SSC: Seat size code

●: Standard items

Recommended Cutting Conditions

ISO	Material	Condition	Tensile Strength (N/mm ²)	Hardness HB	Material No.	Cutting speed Vc(m/min)	Feed (mm/rev) vs. drill diameter	
							Ø4-4.9	Ø5-5.9
P	Non-alloy steel, cast steel, free cutting steel	<0.25%C Annealed	420	125	1	80-140	0.04-0.08	0.07-0.11
		>=0.25%C Annealed	650	190	2	80-130	0.04-0.08	0.07-0.11
		<0.55%C Quenched and tempered	850	250	3	80-120	0.04-0.08	0.07-0.11
		>=0.55%C Annealed	750	220	4	70-110	0.04-0.08	0.07-0.11
		Quenched and tempered	1000	300	5	50-90	0.04-0.08	0.07-0.11
	Low alloy steel and cast steel (less than 5% of alloying elements)	Annealed	600	200	6	70-120	0.04-0.08	0.07-0.13
		Quenched and tempered	930	275	7	70-110	0.04-0.08	0.07-0.13
			1000	300	8	50-90	0.04-0.08	0.07-0.13
			1200	350	9	40-70	0.04-0.08	0.07-0.13
	High alloy steel, cast steel and tool steel	Annealed	680	200	10	50-90	0.06-0.08	0.07-0.11
		Quenched and tempered	1100	325	11	40-80	0.06-0.08	0.07-0.11
M	Stainless steel and cast steel	Ferritic / martensitic	680	200	12	40-70	0.05-0.07	0.06-0.08
		Martensitic	820	240	13	40-70	0.05-0.07	0.06-0.08
		Austenitic	600	180	14	30-70	0.05-0.07	0.06-0.08
K	Gray cast iron (GG)	Ferritic		160	15	90-160	0.04-0.08	0.10-0.15
		Pearlitic		250	16	80-140	0.04-0.08	0.10-0.15
	Cast iron nodular (GGG)	Ferritic		180	17	90-180	0.04-0.08	0.10-0.15
		Pearlitic		260	18	80-140	0.04-0.08	0.10-0.15
	Malleable cast iron	Ferritic		130	19	90-160	0.04-0.08	0.10-0.15
		Pearlitic		230	20	80-140	0.04-0.08	0.10-0.15

■ Steel
 ■ Stainless steel
 ■ Cast iron

CONTACT US



MEGA TECH METALWORK CO.,LTD (Headquarter)



Tel : 02-943-1591



Fax : 02-943-1592



Line ID : @mgt_metalwork



Email : sales.m@mgtg.co.th



Web : <https://www.mgtg.co.th/>



**17/4 Soi Ramintra 89
Ramintra Khannayao
Bangkok 10230**

