

NEW PRODUCT NEWS



Taegutec Turning Line

HUSHBORE

ANTI VIBRATION BAR



Ø80 ANTI - VIBRATION BORING BARS
WITH EXCHANGEABLE HEADS



KEY POINT

HUSHBORE line introduces Ø80 head exchangeable anti-vibration boring bars



With a new Ø80 shank and a dedicated head introduced to the anti-vibration HUSH-BORE boring bar line specialized in deep internal machining, TaeguTec has expanded its reach in the deep internal machining market.

Available in two types: a modular head with standard inserts for machining various materials, and an adapter that can machine while fastened to a standard square holder, allowing for relatively large diameter internal machining.

Features

- Shanks include built-in vibration damping technology
 - Good surface roughness and improved tool life
- Stainless steel shank prevents corrosion
- Shank diameter: Ø80, length: 7xD, 10xD (available as standard items in 2 types)
- Available in various dedicated head types
- Dedicated Adapter use a 20x20 standard square holder
- Internal coolant type

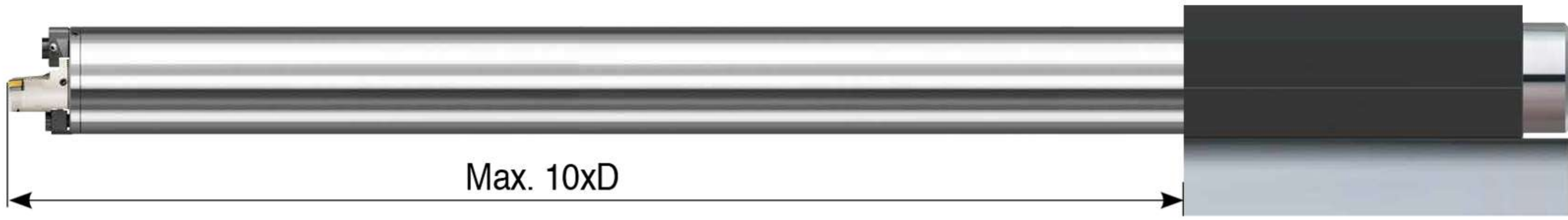
HUSH-BORE Shank

new Ø80	
Ø16-Ø60	



Taegutec Turning Line

Head assembly instructions



❶ Loosen the screw.



❷ Slide the head into the slot.



❸ Tighten the screw.

Square holder assembly instructions



❶ Remove the lower clamp.



❷ After sliding the adapter into the boring bar, tighten the clamp screw.



❸ Slide the square holder into the adapter and tighten the adapter screw.

Taegutec Turning Line

QS-VH



Anti-Vibration shanks for boring

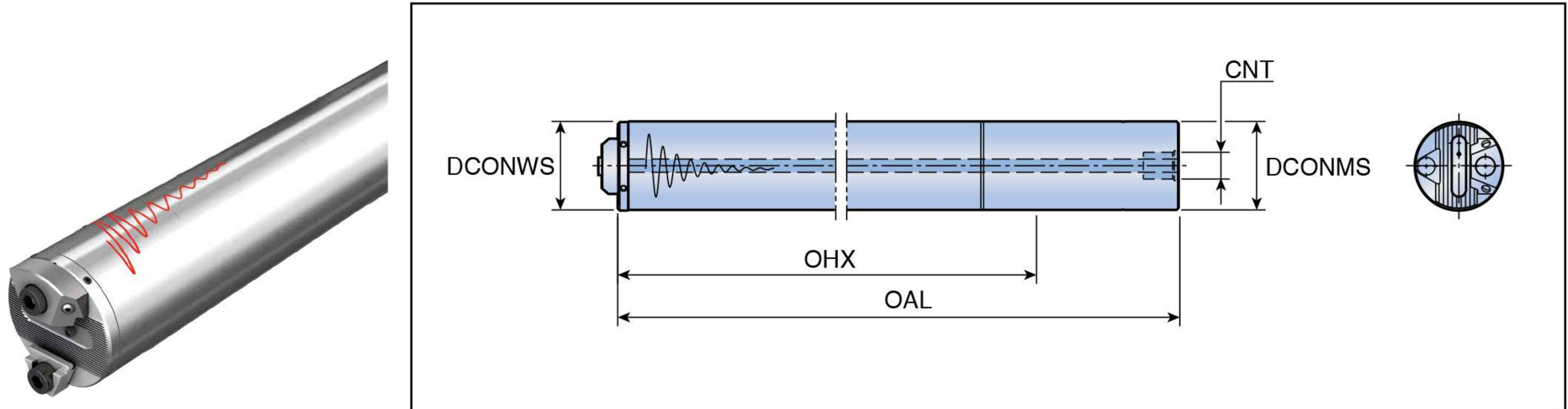

Designation	Dimension (mm)					Coolant hole
	DCONMS	DCONWS	OAL	OHX	CNT	
QS80A-7D-VH	80	80	880	515	G 3/4"	●
10D-VH	80	80	1200	755	G 3/4"	●

▶ OHX: Maximum overhang

QH-SDUCR/L-VH



Screw type boring heads

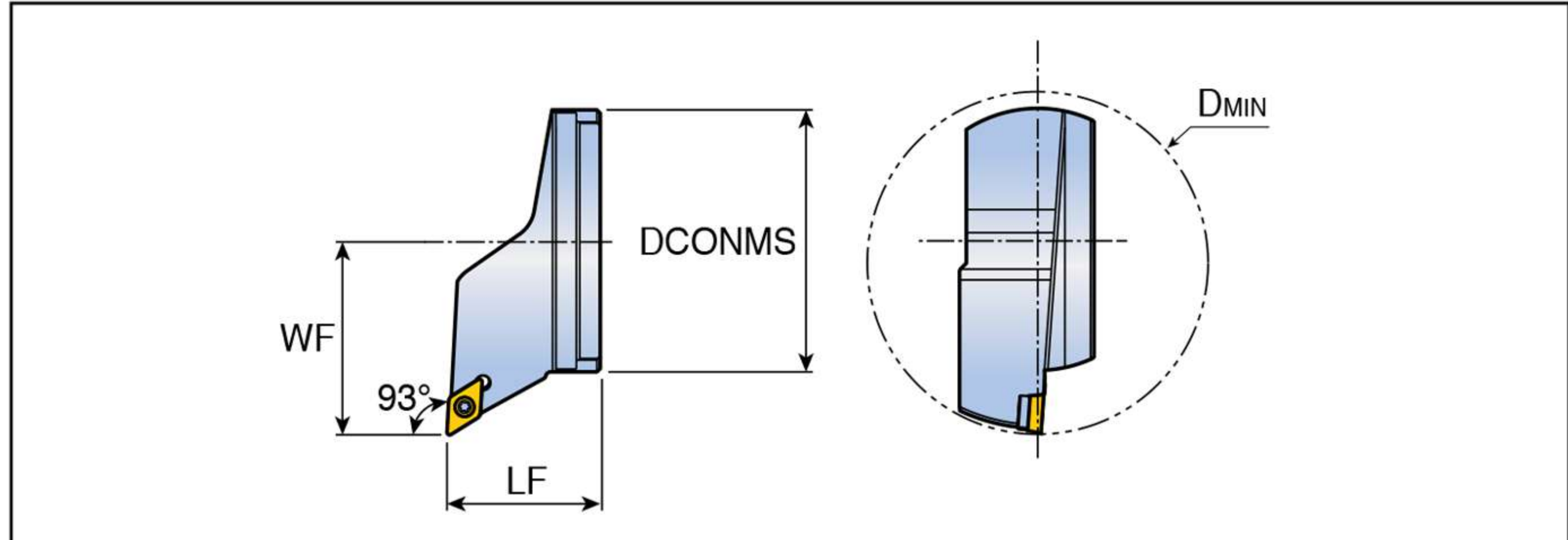

Approach angle	Designation	Dimension (mm)				Insert
		DCONMS	LF	WF	DMIN	
93°	QH80-SDUCR/L-11-VH	77	45	57	100	DC...T 11T3...

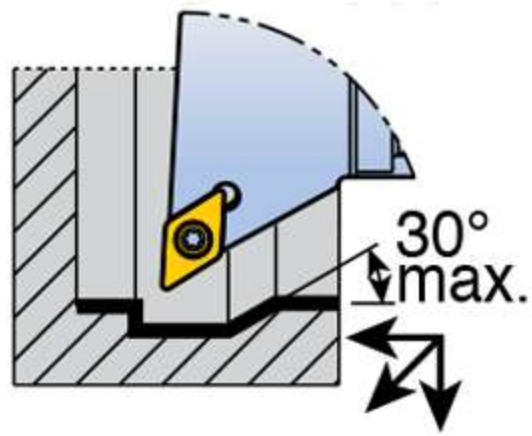

QH-SVLCR/L-VH



Screw type boring heads

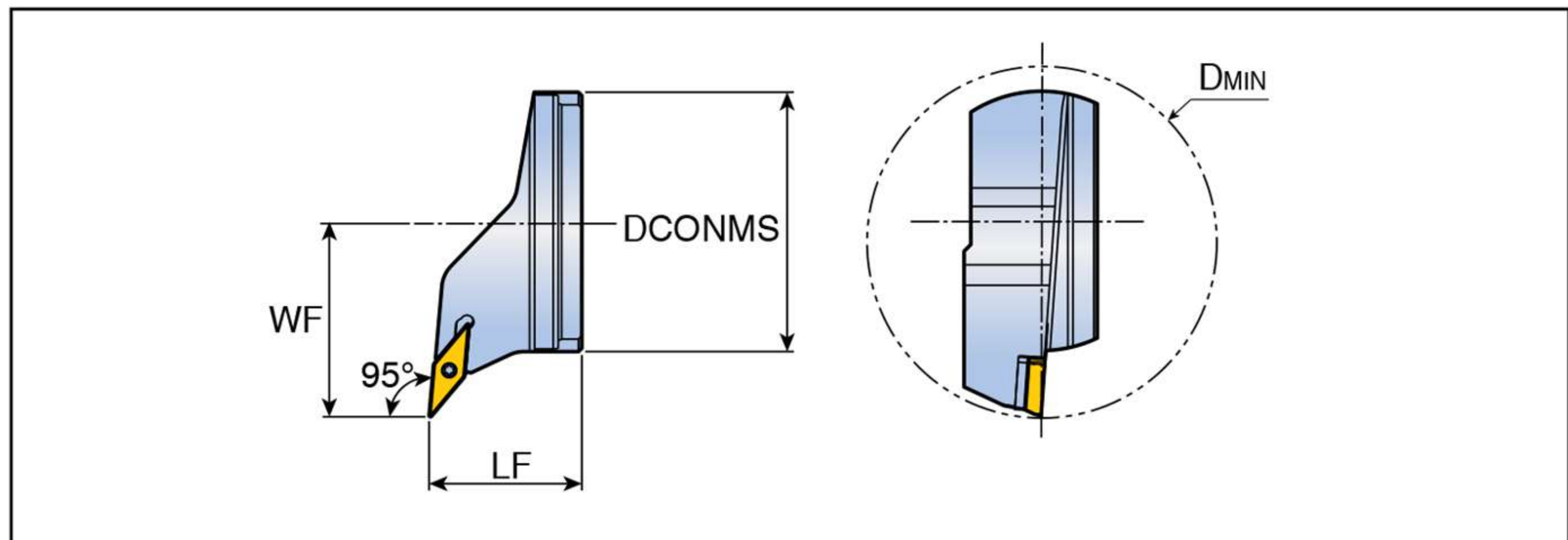

Approach angle	Designation	Dimension (mm)				Insert
		DCONMS	LF	WF	DMIN	
95°	QH80-SVLCR/L-16-VH	77	45	57	100	VC...T 1604...

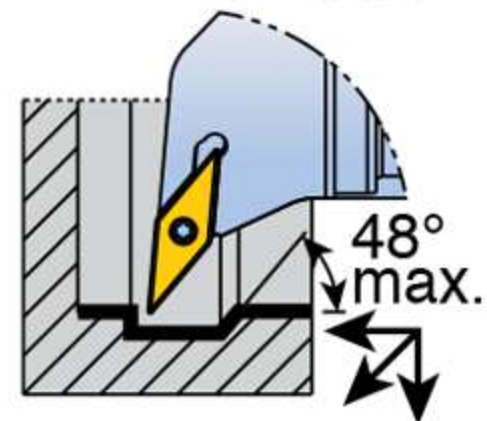

Spare parts

Designation	Screw	Shim		Shim screw	Stopper screw	Wrench	
SDUCR/L	SR 16-236 P	TDC 3-1P	-	SR TC-3P	SH M3x0.5x6	T-15/5	L-W 4 L-W 2.5
SVLCR/L...	SR 16-236 P	-	TVC 3-1P	SR TC-3P	SH M3x0.5x6	T-15/5	L-W 4 L-W 2.5

QH80-VH

Perpendicular adaptor for external square-shank tools

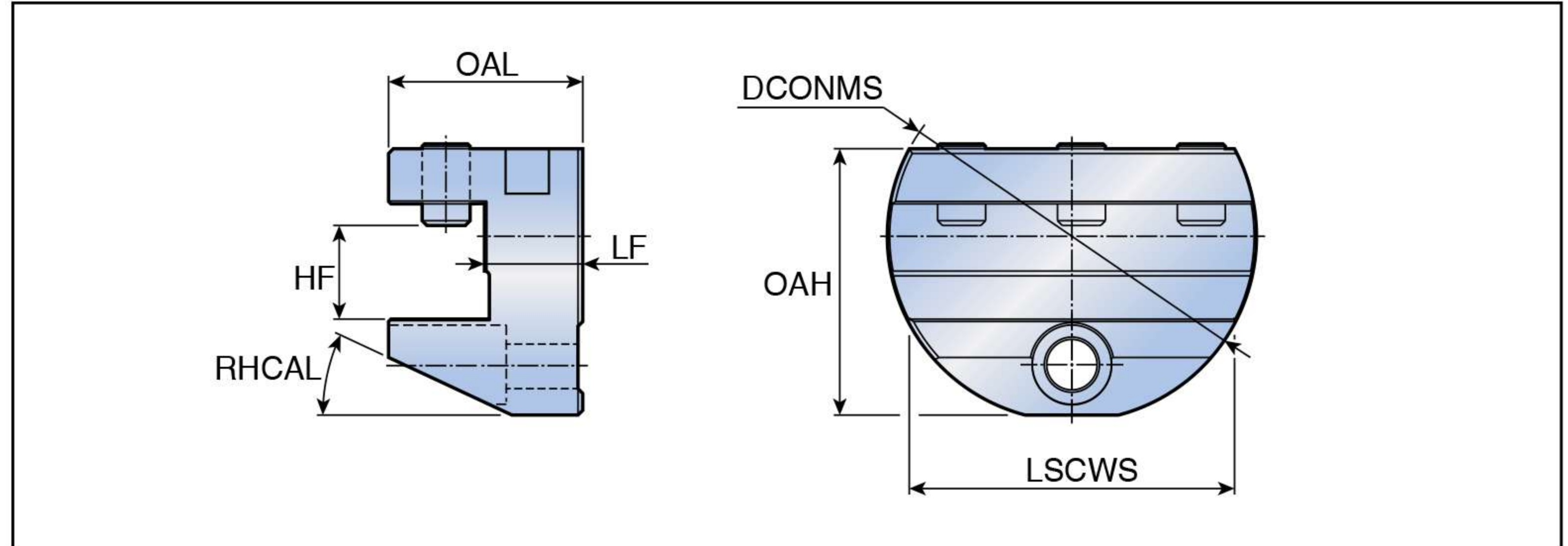

Designation	Dimension (mm)						
	DCONMS	LF	HF	OAL	OAH	LSCWS	RHCAL
QH80-2020-VH	77.0	20.5	20.0	40.5	55.5	67.8	25.0

- ▶ Used with external 20x20 square holders
- ▶ Since there is a deviation in the D_{MIN} value for each holder, it is recommended to use the boring head after checking for interference with the workpiece.

Spare parts

Designation	Screw	Wrench				
QH80	SR M10x16 DIN913	L-W 5				

CONTACT US



MEGA TECH METALWORK CO.,LTD (Headquarter)



Tel : 02-943-1591



Fax : 02-943-1592



Line ID : @mgt_metalwork



Email : sales.m@mgtg.co.th



Web : <https://www.mgtg.co.th/>



**17/4 Soi Ramintra 89
Ramintra Khannayao
Bangkok 10230**

