

NEW PRODUCT NEWS

**MEGA
TECH**
METAL WORK CO.,LTD

Taegutec Milling Line

CHASE8MILL
90° FACING & SHOULDERING

**90° SHOULDERING
WITH 8-CUTTING EDGE**

SQKU 10 INSERT LAUNCH



ADVANCECUTTING
TaeguTec

TaeguTec
Member IMC Group

KEY POINT

TaeguTec introduces a new SQKU 10 insert and dedicated cutter to the CHASE-8-MILL product line.

With the growing popularity of the SQKU 07 and 12 insert lines to meet the equally growing demand, TaeguTec has now added the SQK(H)U 10 size insert. The current 07 and 12 lines are divided into the M chip former for the SQKU 07 size and MP/MMP chip former type for the size 12 insert. The newly introduced size 10 insert includes both the M and MP/MMP chip former types. The M type chip former is capable of multi-step machining while the MP/MMP type chip former is specialized for facing and shouldering in limited depth of cut operations. The new SQKU 10 insert is compatible with cutters regardless of chip former type and is a complete milling solution, allowing the end-user to select the optimal chip former by application.

For further information, please contact the product manager.

CHASE-8-MILL SQK(H)U insert

SQKU 07	new SQK(H)U 10		SQK(H)U 12
M	M	MP/MMP	MP/MMP
			



Taegutec Milling Line

Features

- Economical, double-sided 8-corner insert
- Precision 90-degree right angle machining
 - M chip former
Minimizes mismatch in multi-step machining

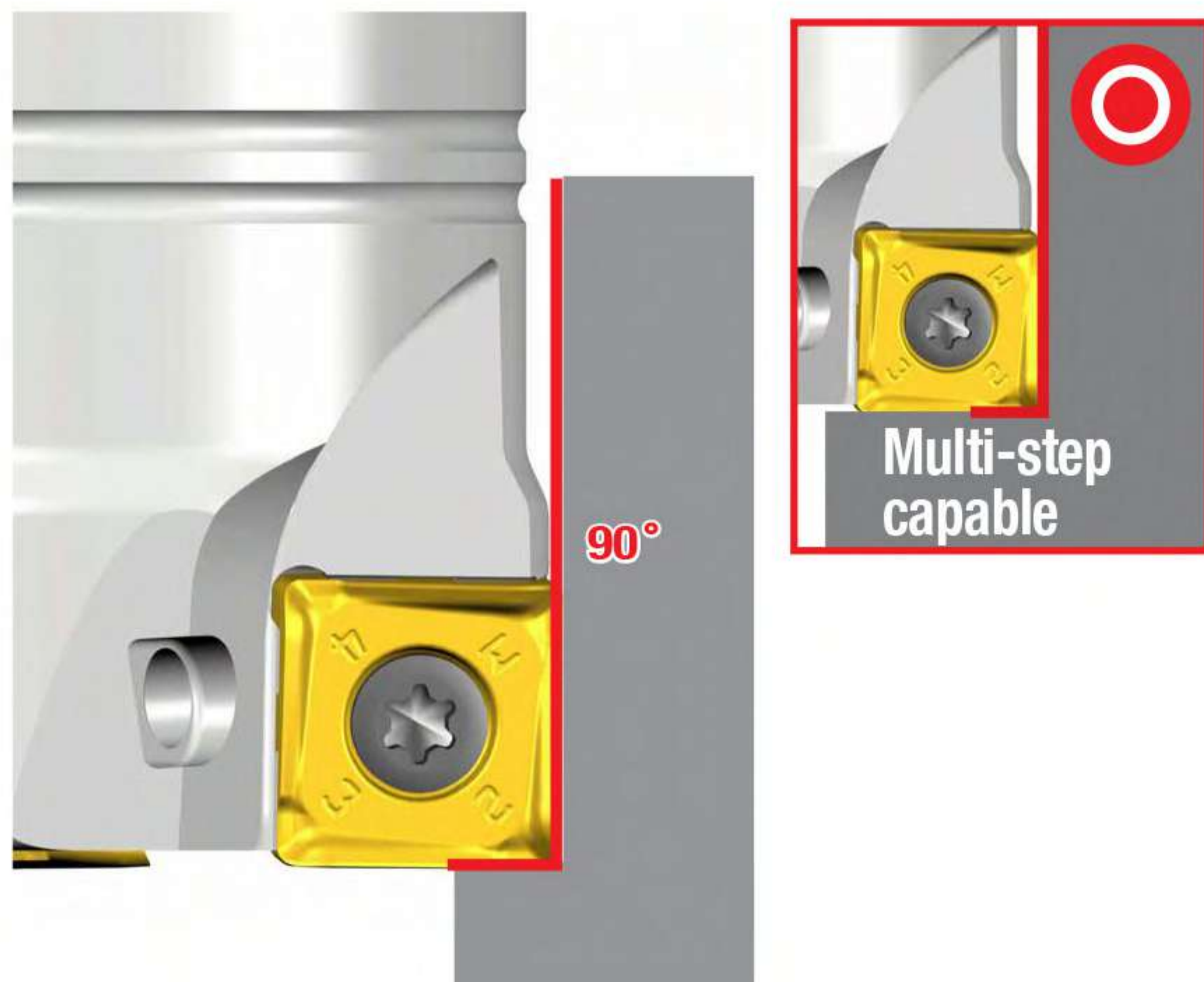

- MP/MMP chip former
Specialized in facing and shouldering in limited depth of cut operations

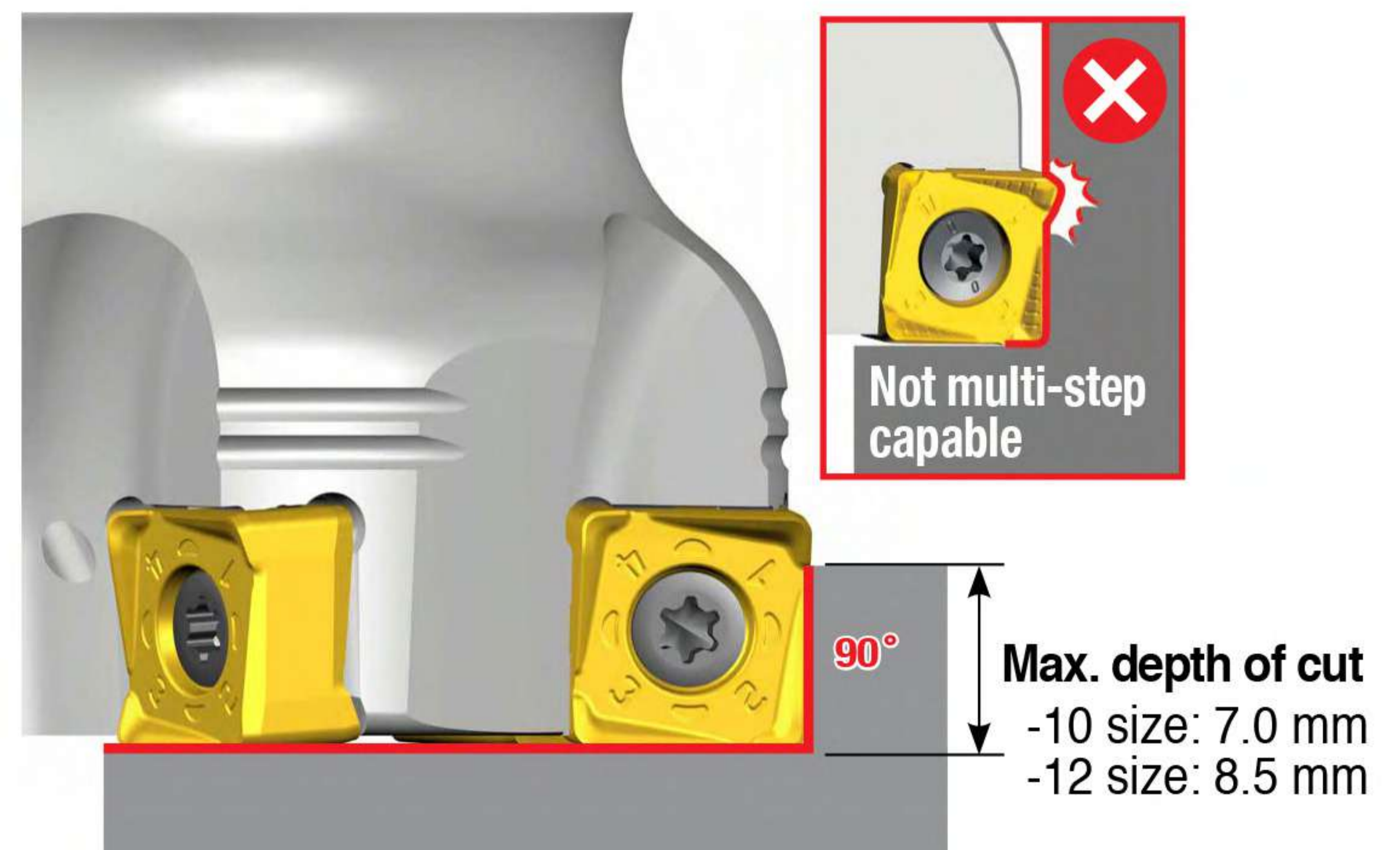

- Insert's wiper edge improves surface finish

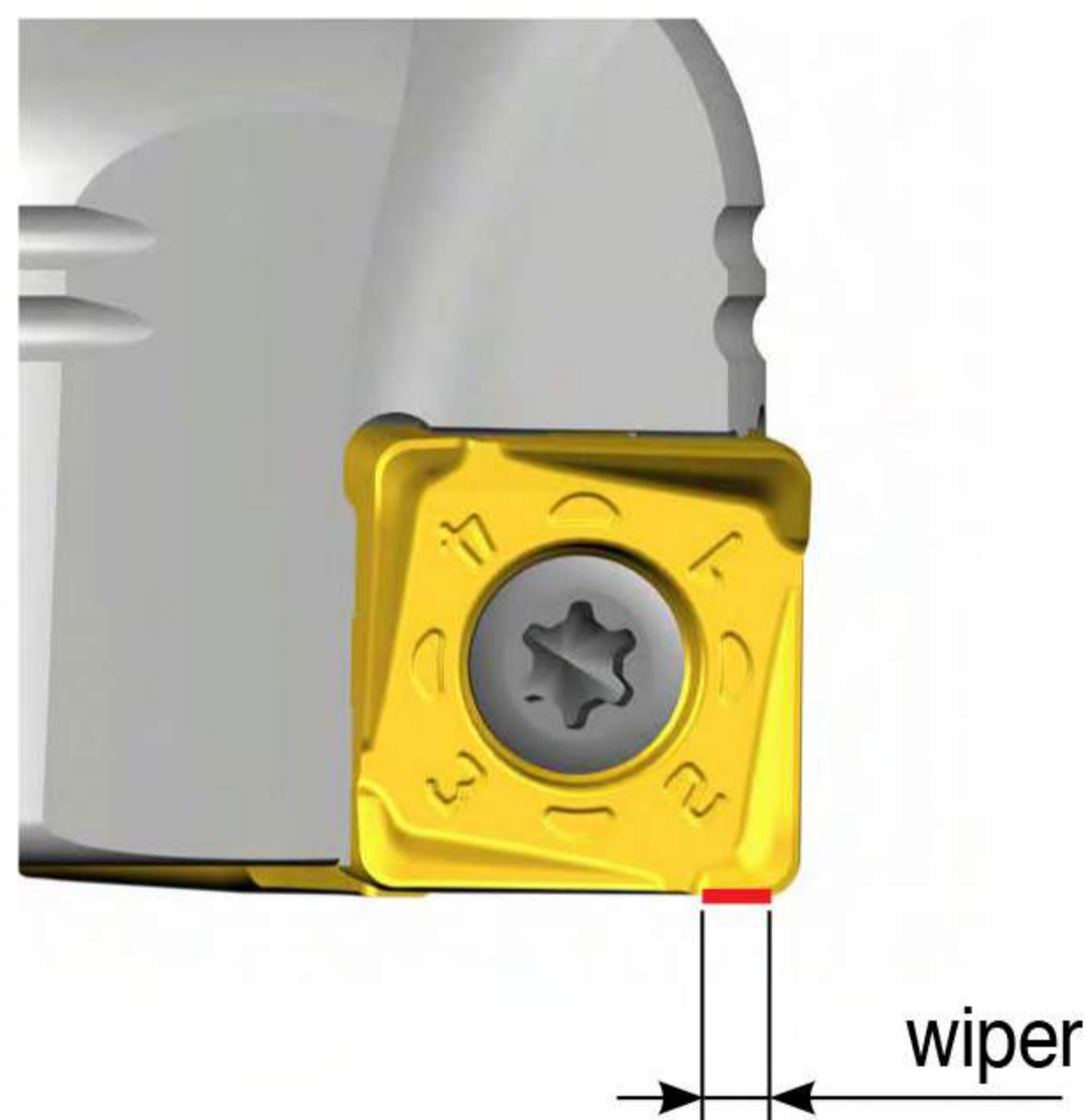



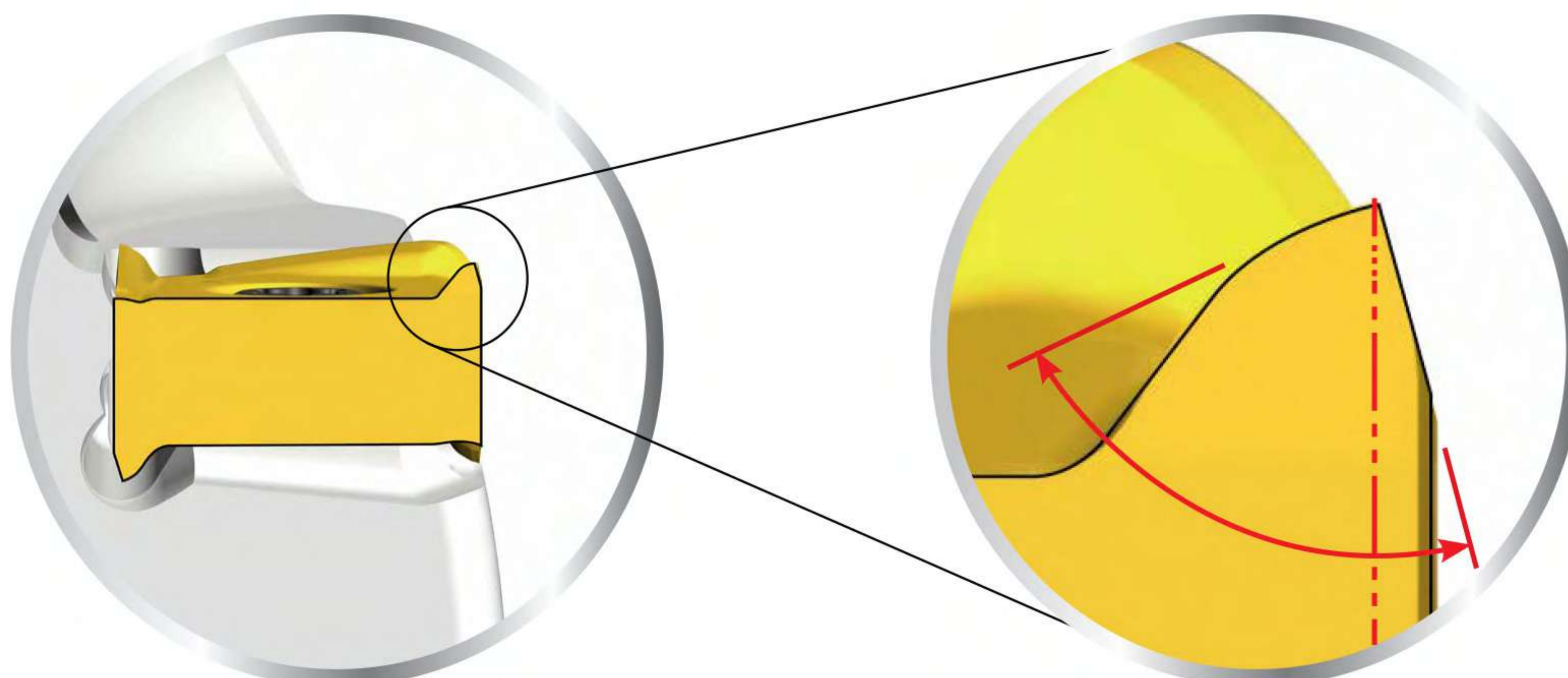

- Insert's reinforced cutting edge enhances machining stability

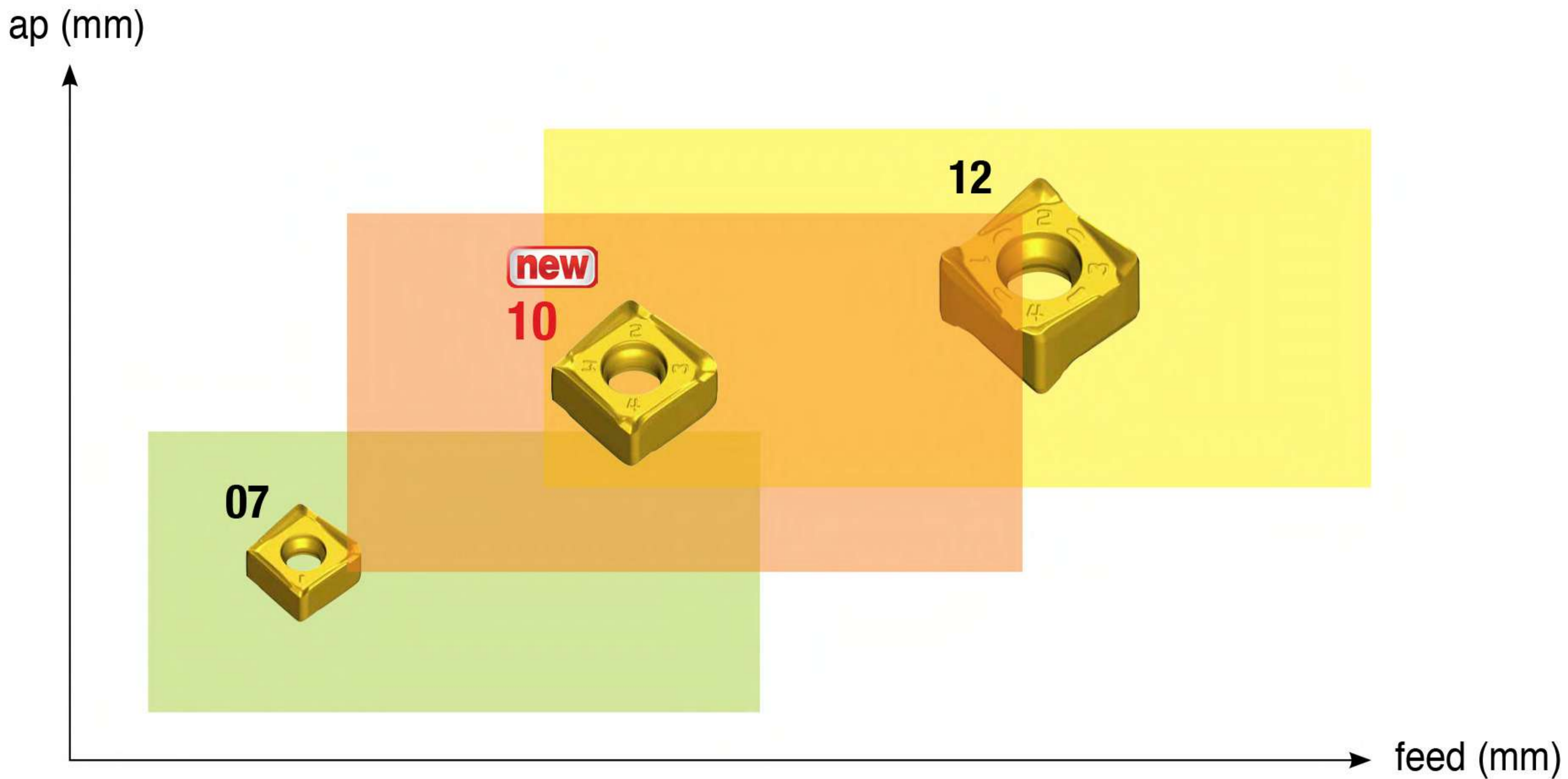

Machining range by SQK(H)U insert size



CHASE-8-MILL cutter diameter range

Inserts	Modular heads	End mills	Face mills
			
SQKU 07	Ø16-Ø40	Ø16-Ø40	Ø32-Ø63
new SQK(H)U 10	Ø25-Ø40	Ø25-Ø40	Ø40-Ø125
SQK(H)U 12	-	Ø32-Ø40	Ø40-Ø160

Taegutec Milling Line

8D-TE90-10



End mills

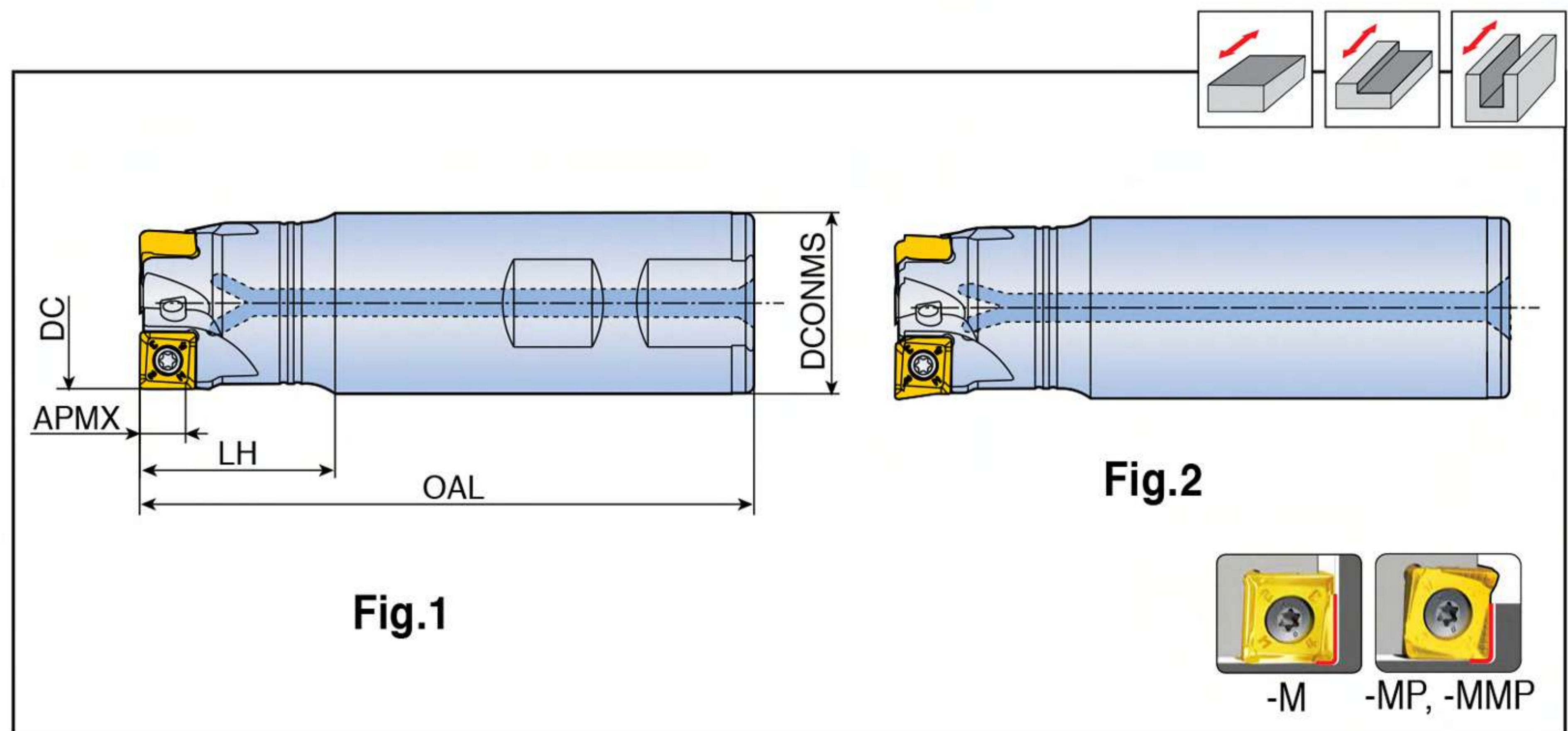
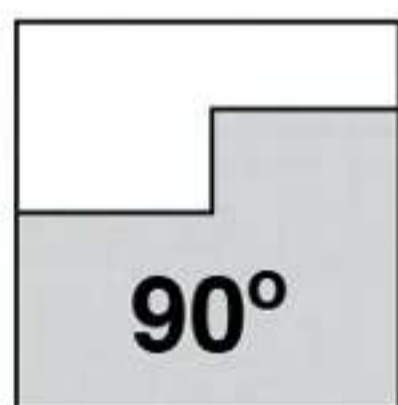

Designation	⊙	Dimension (mm)					Coolant hole	Fig.	Insert
		DC	DCONMS	OAL	LH	APMX			
8D-TE90-225-W25-10	2	25	25	100	30	7.0*	●	1	SQK(H)U 1004...
225-25-10-L160	2	25	25	160	30	7.0*	●	2	
332-W32-10	3	32	32	110	35	7.0*	●	1	
332-32-07-L200	3	32	32	200	35	7.0*	●	2	
440-W32-10	4	40	32	110	40	7.0*	●	1	

▶ *When applying SQHU insert, APMX is 6.5 mm.

8D-TE90-M-10



Modular heads

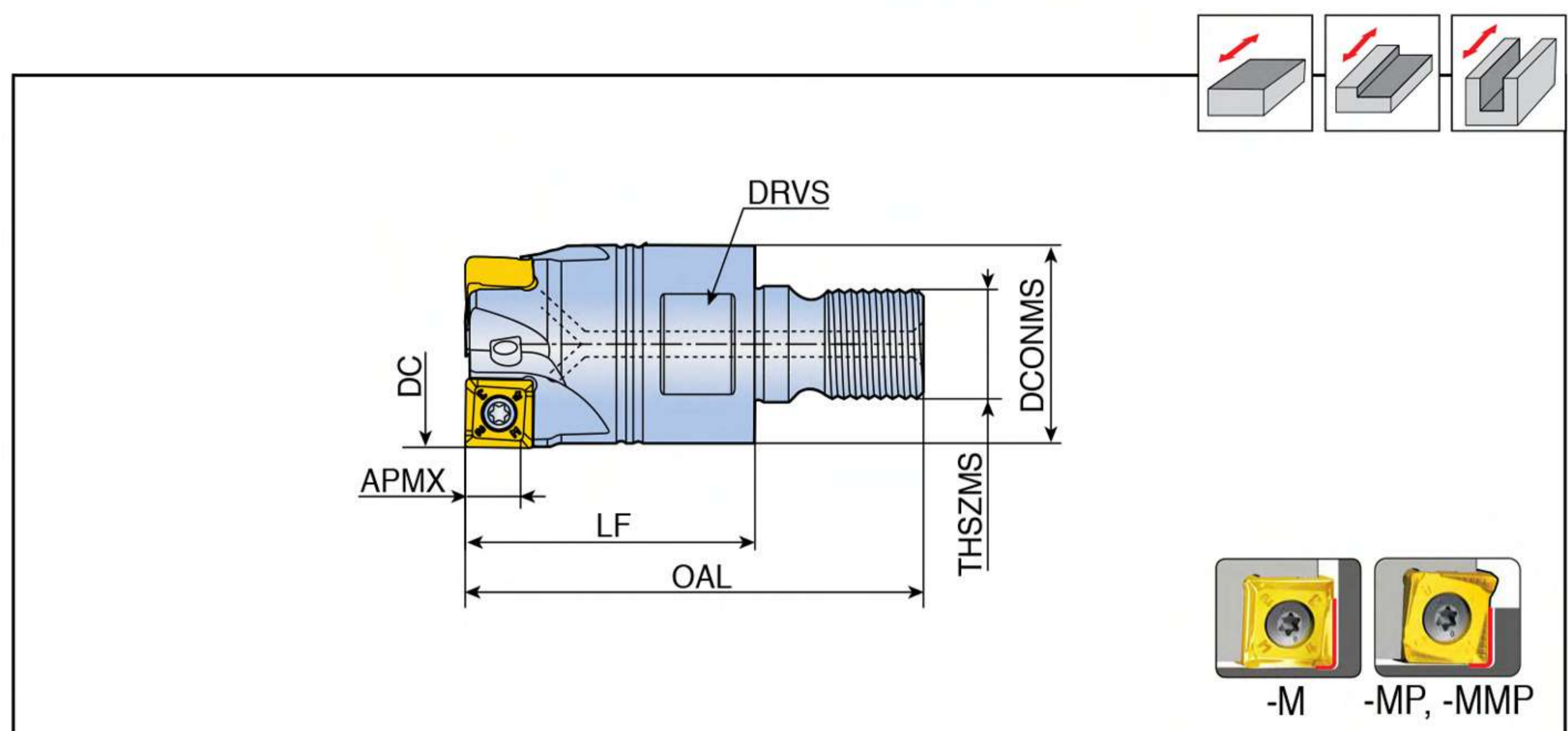
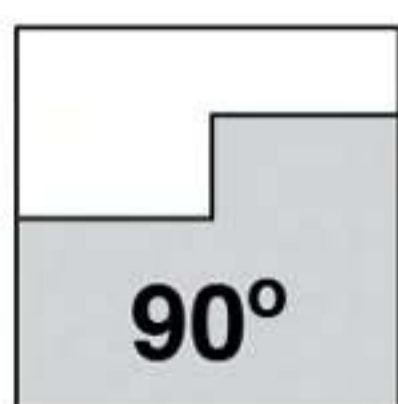

Designation	⊙	Dimension (mm)							Coolant hole	Insert
		DC	DCONMS	LF	OAL	THSZMS	APMX	DRVS		
8D-TE90-225-M12-10	2	25	22	35	57	M12	7.0*	17	●	SQK(H)U 1004...
332-M16-10	3	32	29	43	68	M16	7.0*	25	●	
440-M16-10	4	40	29	43	68	M16	7.0*	25	●	

▶ Matched with T-FLEXTEC holder

▶ *When applying SQHU insert, APMX is 6.5 mm.

Spare parts

Designation	Screw	Wrench			
8D-TE90-10	TS 35A088I/HG	TD 10P			

Taegutec Milling Line

8D-TF90-10



Face mills

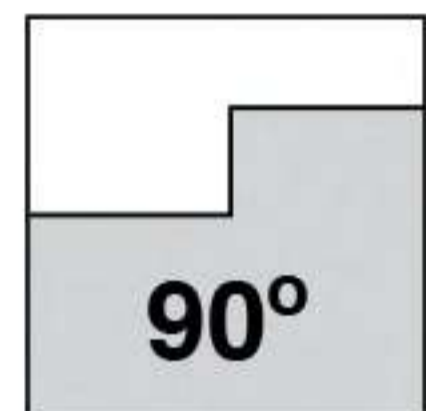
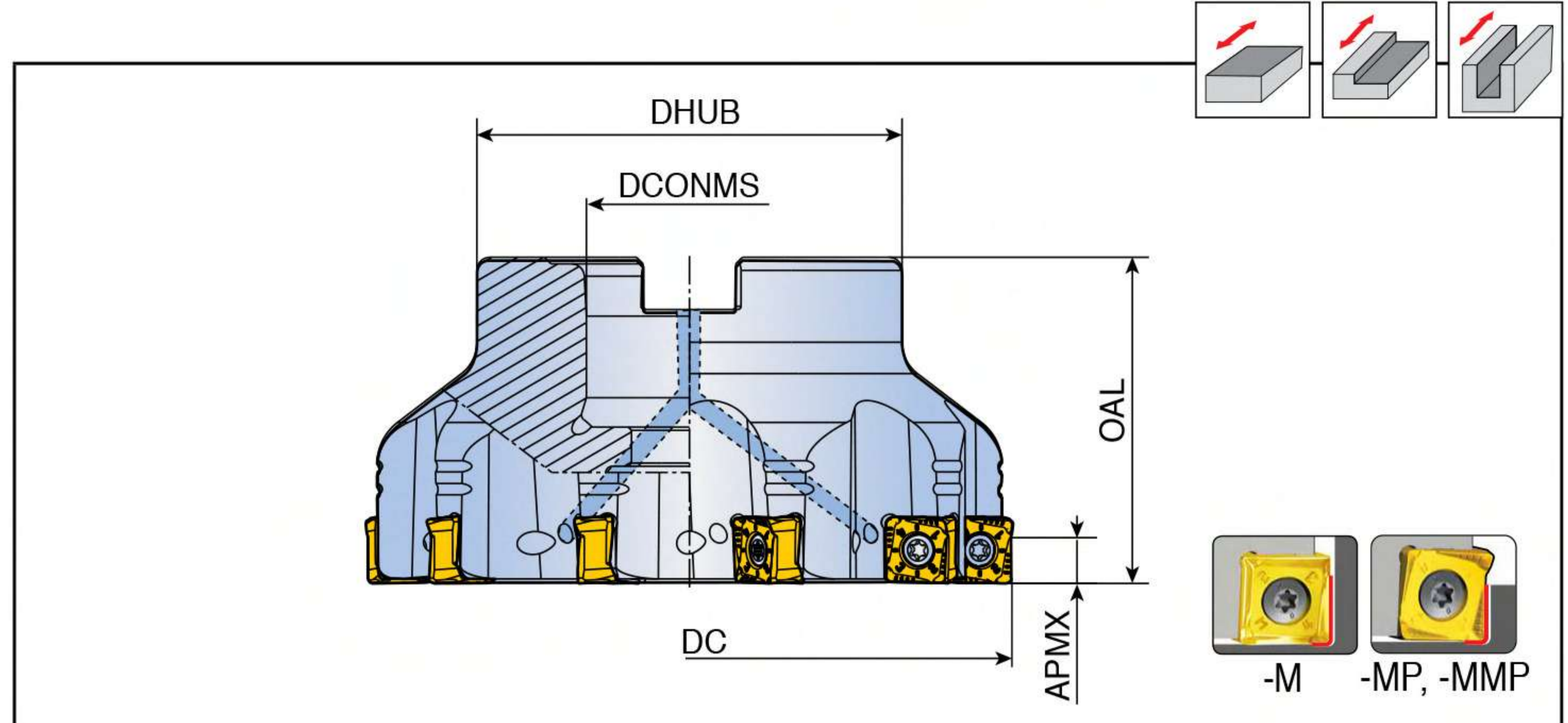

Designation	Z	Dimension (mm)					Coolant hole	Arbor type	Kg	Mounting bolt	Insert
		DC	DCONMS	DHUB	OAL	APMX					
8D-TF90-440-16R-10	4	40	16	38	40	7.0*	●	A	0.2	SH M8x25	SQK(H)U 1004...
550-22R-10	5	50	22	45	40	7.0*	●	A	0.3	SH M10x30	
663-22R-10	6	63	22	47	40	7.0*	●	A	0.5	SH M10x30	
863-22R-10	8	63	22	47	40	7.0*	●	A	0.5	SH M10x30	
880-27R-10	8	80	27	58	50	7.0*	●	A	1.1	SH M12x35	
1080-27R-10	10	80	27	58	50	7.0*	●	A	1.1	SH M12x35	
10100-32R-10	10	100	32	66	50	7.0*	●	A	1.6	SH M16x35	
14100-32R-10	14	100	32	66	50	7.0*	●	A	1.7	SH M16x35	
12125-40R-10	12	125	40	85	63	7.0*	●	A	3.4	SH M20x40	
16125-40R-10	16	125	40	85	63	7.0*	●	A	3.5	SH M20x40	

- ▶ Mounting bolt with coolant through hole is available on request (ordering example: SH M10x1.5x30-C)
- ▶ *When applying SQHU insert, APMX is 6.5 mm.

Spare parts

Designation	Screw	Wrench			
8D-TF90-10	TS 35A088I/HG	TD 10P			

SQKU 10



Inserts

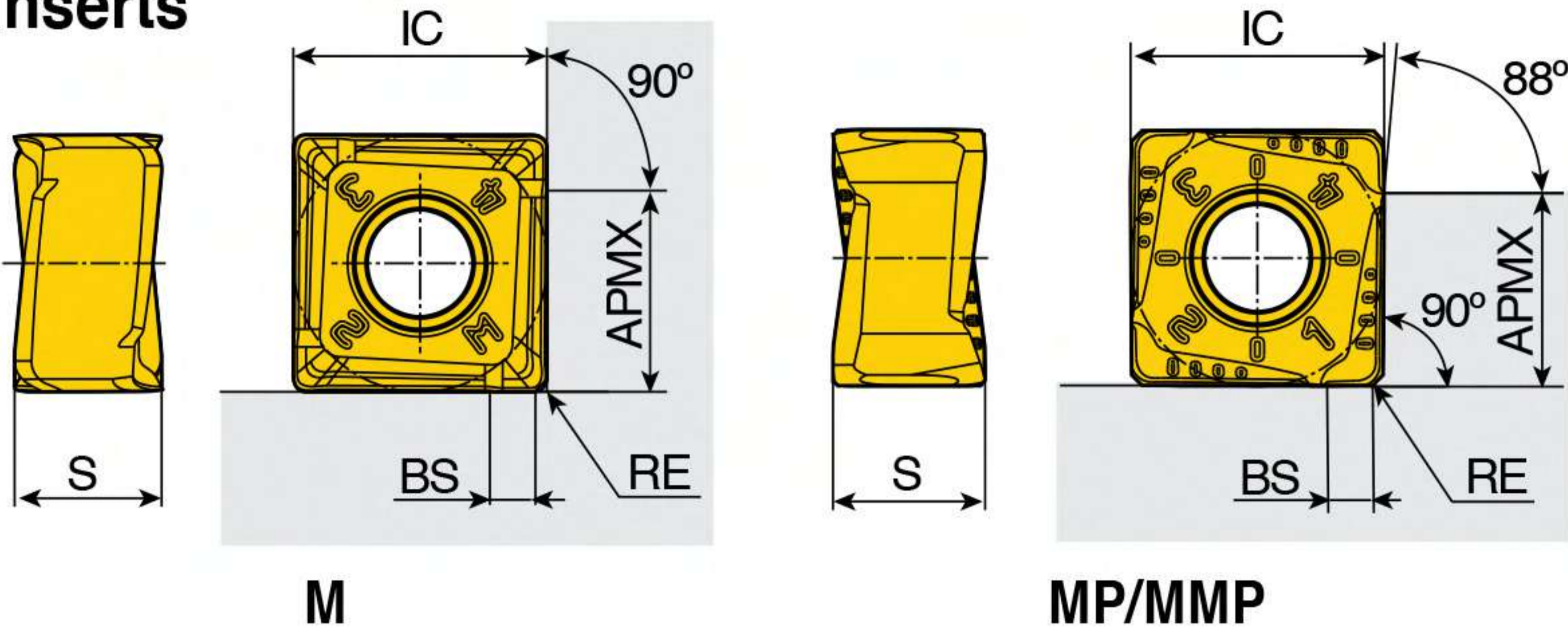

Size	Dimension (mm)				
	IC	S	APMX	BS	RE
10-M	10	5.8	7.0	1.1	0.8
10-MP	10	6	7.0	1.1	0.8
10-MMP	10	6	6.5	1.1	0.8

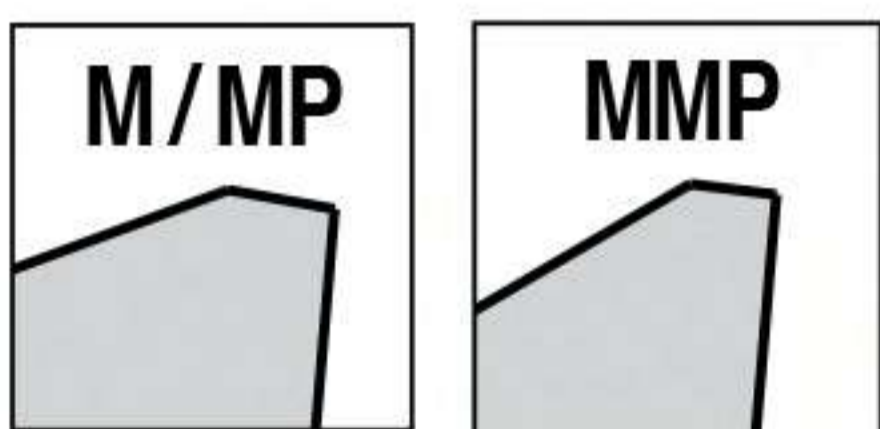

Insert	Designation	Recommended machining conditions		Coated								Uncoated		
		ap (mm)	Feed (mm/tooth)	TT9080	TT9030	TT8080	TT8020	TT8525B	TT7080	TT7515	TT6080	TT2510	K10	
	SQKU 100408 PNR-M	1.5-5.5	0.20-0.10	●		●								
	SQKU 100408 PNR-MP	1.5-5.5	0.20-0.10	●						●				
	SQHU 100408 PNR-MMP	1.5-5.5	0.20-0.10							●				

●: Standard items

CONTACT US



MEGA TECH METALWORK CO.,LTD (Headquarter)



Tel : 02-943-1591



Fax : 02-943-1592



Line ID : @mgt_metalwork



Email : sales.m@mgtg.co.th

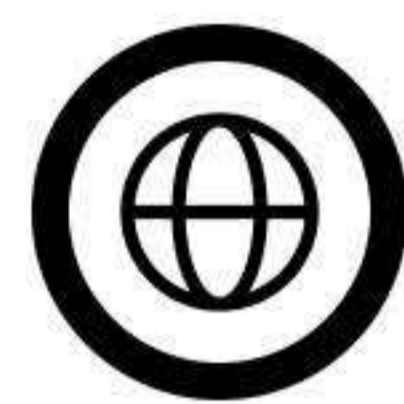

Web : <https://www.mgtg.co.th/>



**17/4 Soi Ramintra 89
Ramintra Khannayao
Bangkok 10230**

