

NEW PRODUCT NEWS

**MEGA
TECH**
METAL WORK CO.,LTD

Taegutec Parting & Grooving Line

QUADRUSH

PARTING & GROOVING



**EXTRA WIDE INSERT BLANKS FOR
SPECIAL PROFILE GROOVING APPLICATIONS**

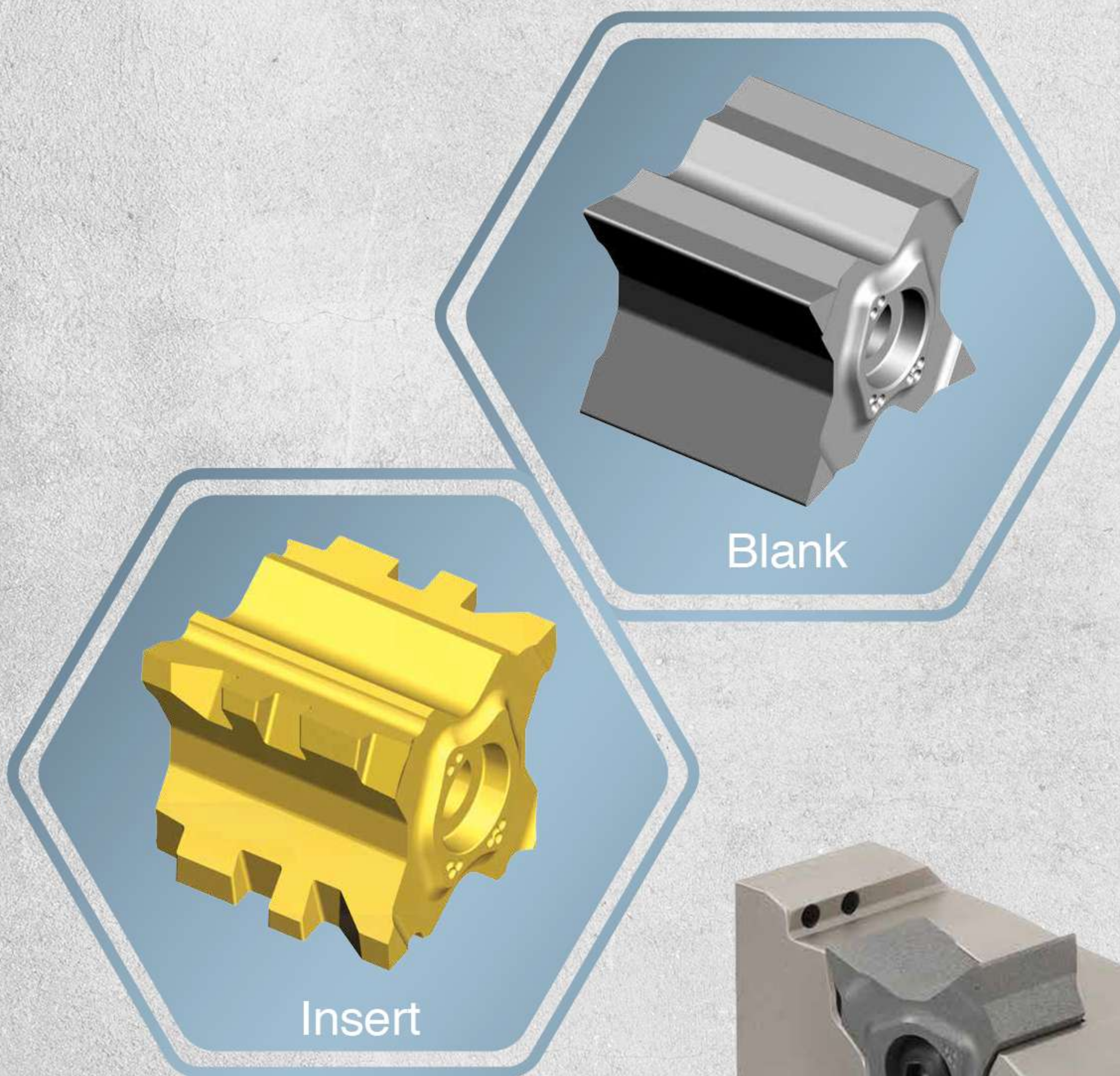

KEY POINT

TaeguTec's QUAD-RUSH line has introduced extra wide grooving inserts and holders for wide profile machining.

The QUAD-RUSH line now includes standard, semi-finished insert blanks for external wide profile grooving in three widths: 10, 15 and 20mm. These insert blanks come in the UF10 uncoated grade, suited for the machining of a wide range of materials and can be used after self-grinding to the desired profile by the end-user.

Additionally, TaeguTec offers grinding profile and coating in accordance with end-user specifications should end-users need custom inserts.

When required, the user can utilize the specific holder as a grinding fixture thanks to its high precision insert positioning and simple yet reliable clamping mechanism. In addition, the COOL-BURST's pinpointed high-pressure coolant supply contributes to longer tool life and improved productivity

Features

- Economical 4-wide cutting edges insert blank
- Insert blanks in 3 different widths: 10, 15 and 20 mm
- Customers can grind special profiles themselves, or TaeguTec can supply tailor-made products
- Smart clamping holder design for stable and robust insert mounting of wide inserts
- High-pressure coolant (COOL-BURST) holder: 20x20 mm, 25x25 mm

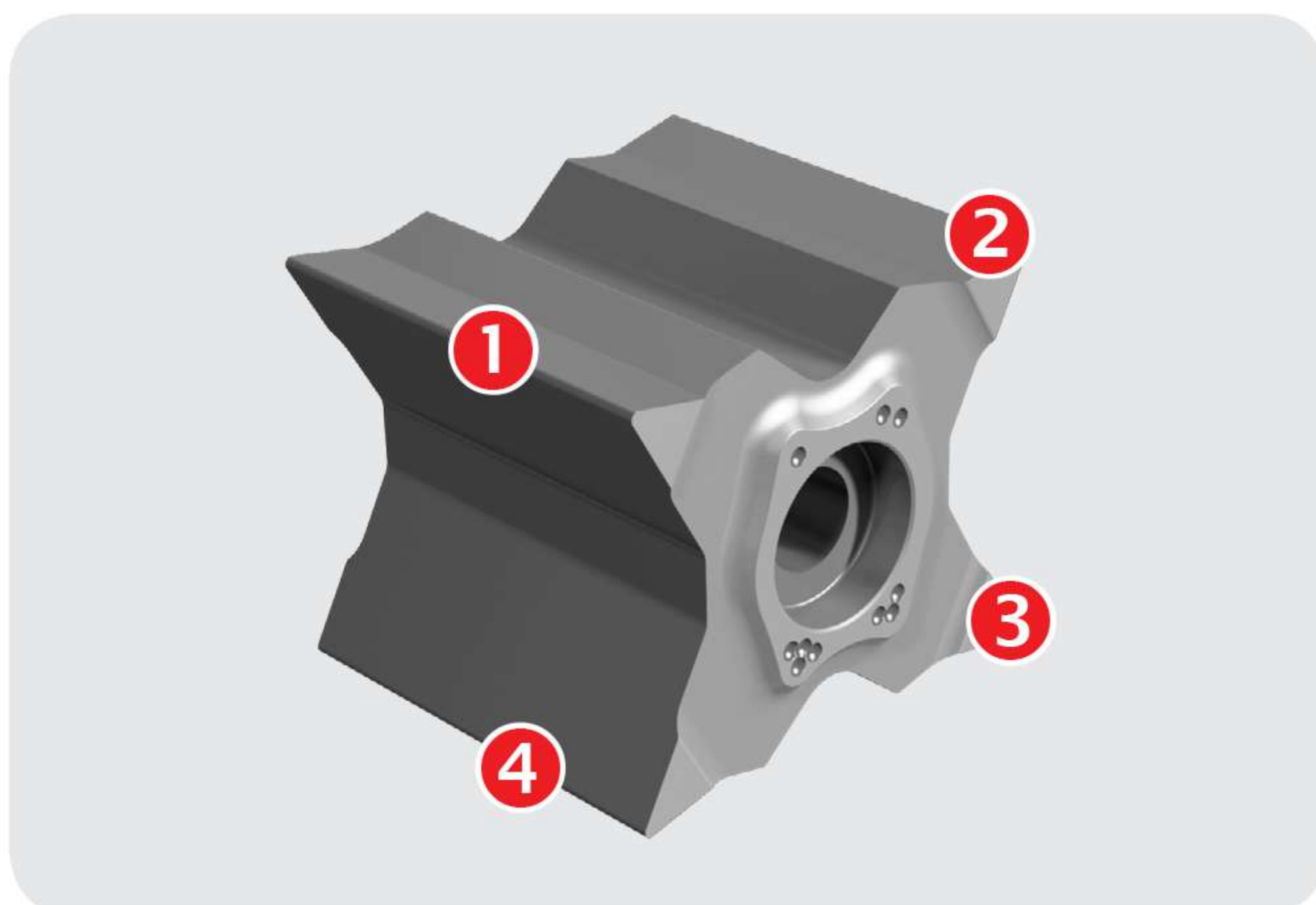

4-corner wide insert



Pinpointed high-pressure coolant supply

Insert mounting instructions

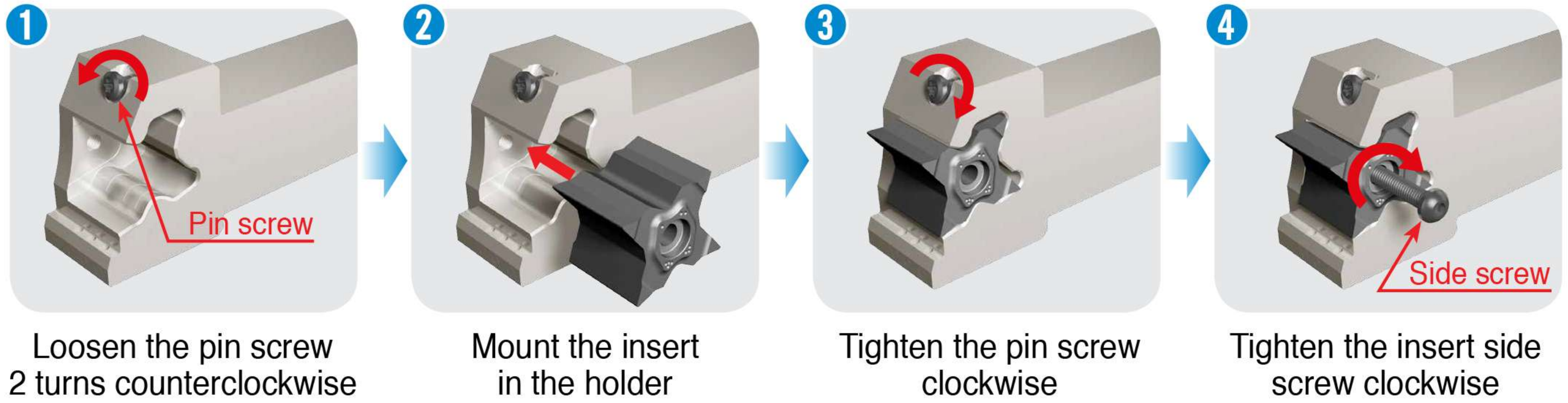

Smart clamping mechanism

- 1 Pin screw clamping (tighten clockwise)
- 2 As the pin descends, press the insert to secure it in the holder.
- 3 4-point (●) contact clamping of the insert by cutting force

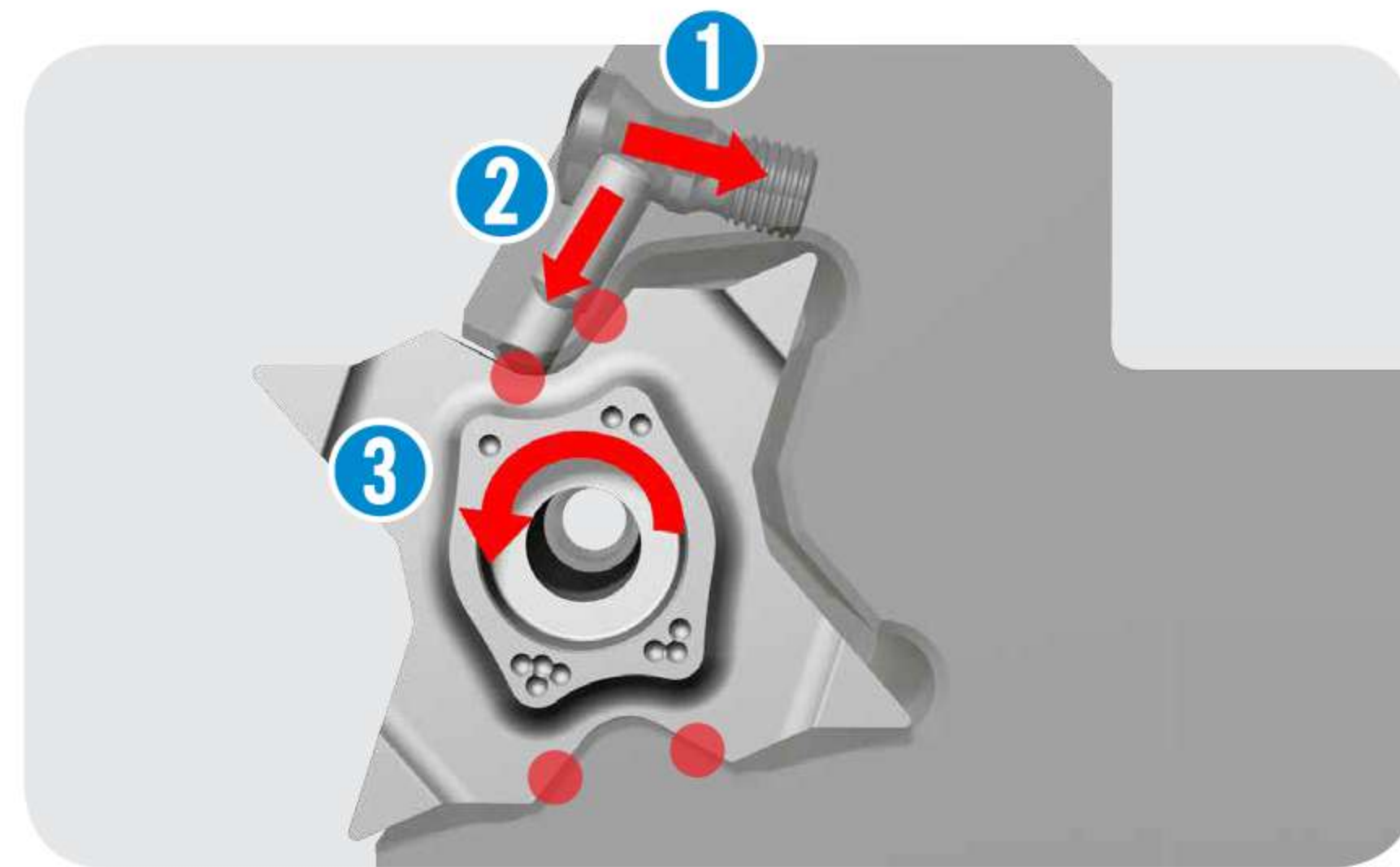

Reference for profile machining

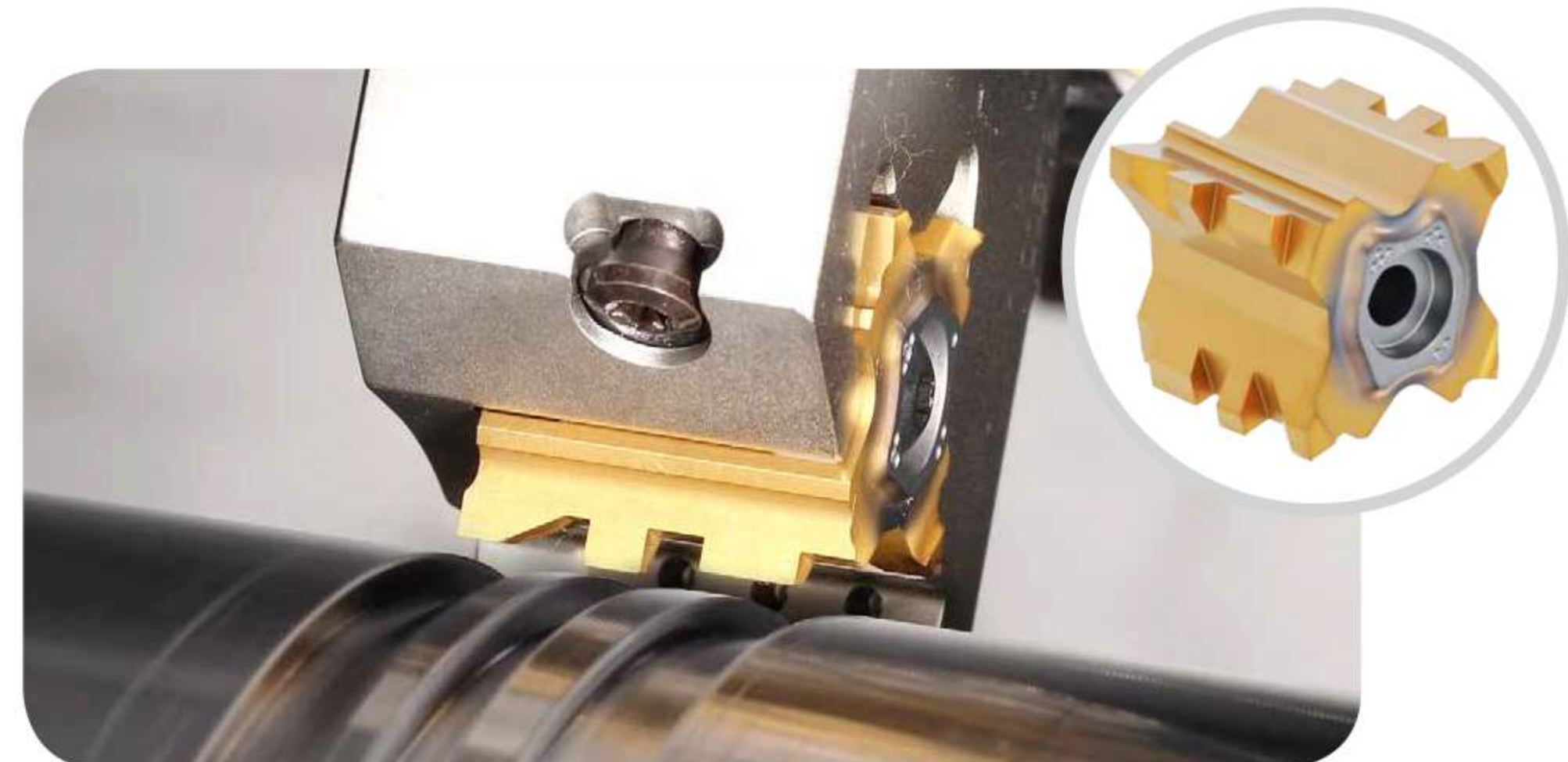

TQHR/L...EW-TB



Holders for external wide grooving and profiling with high-pressure coolant

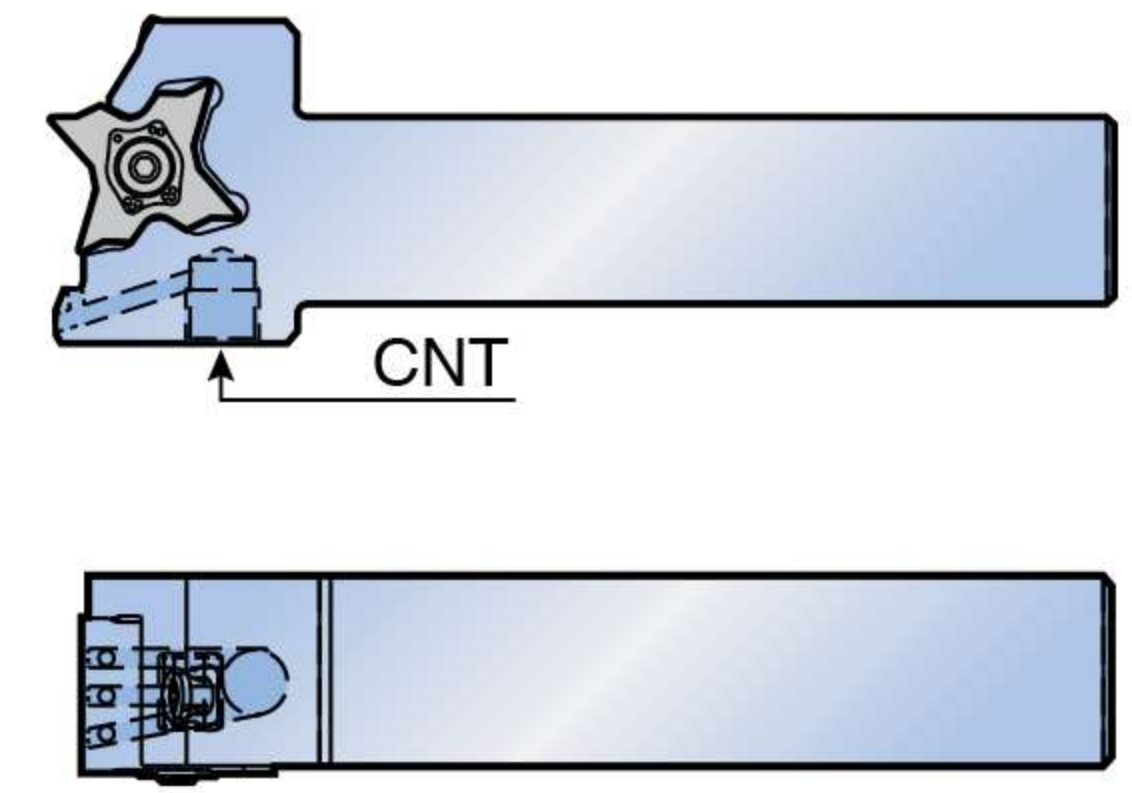
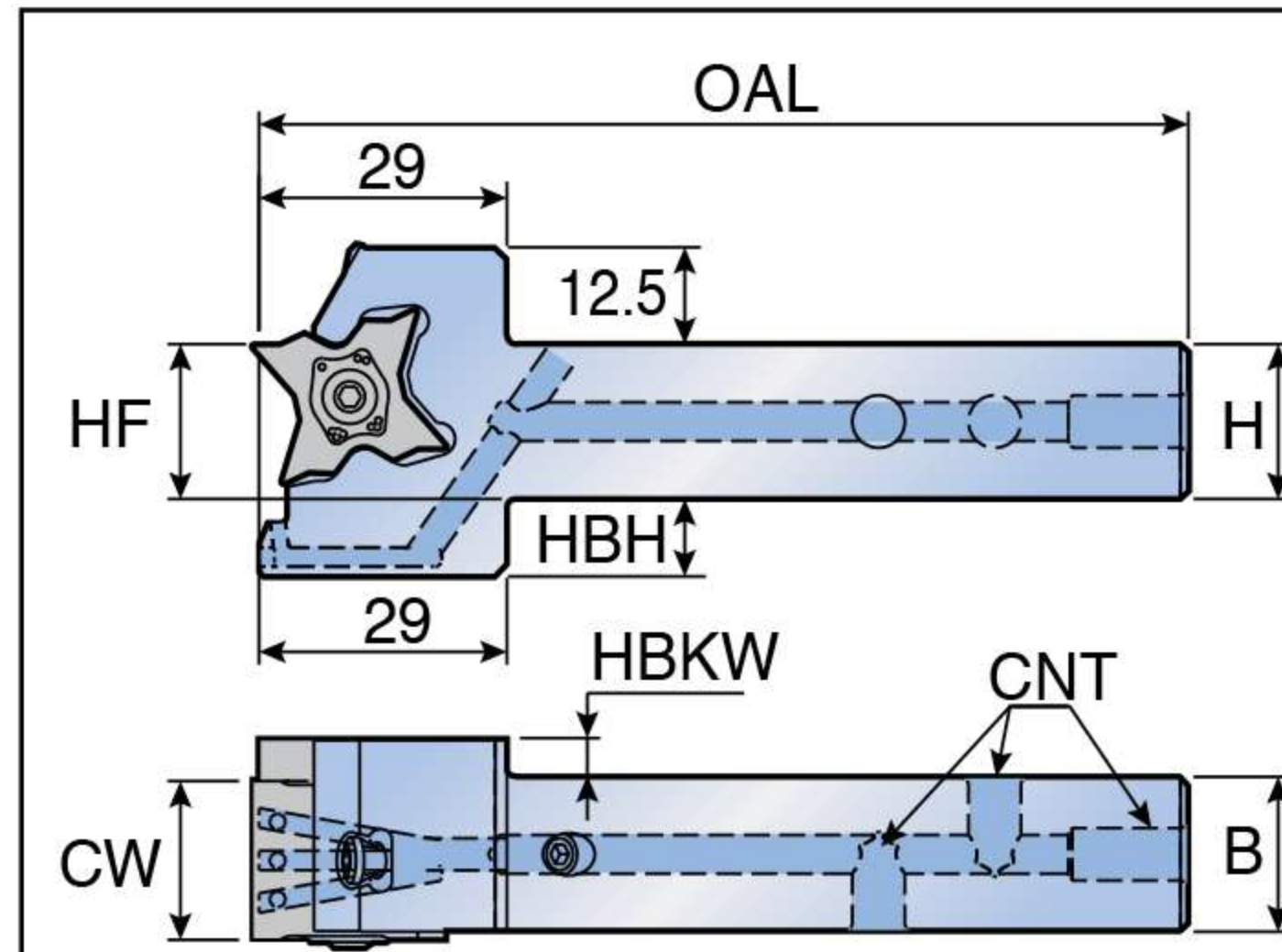
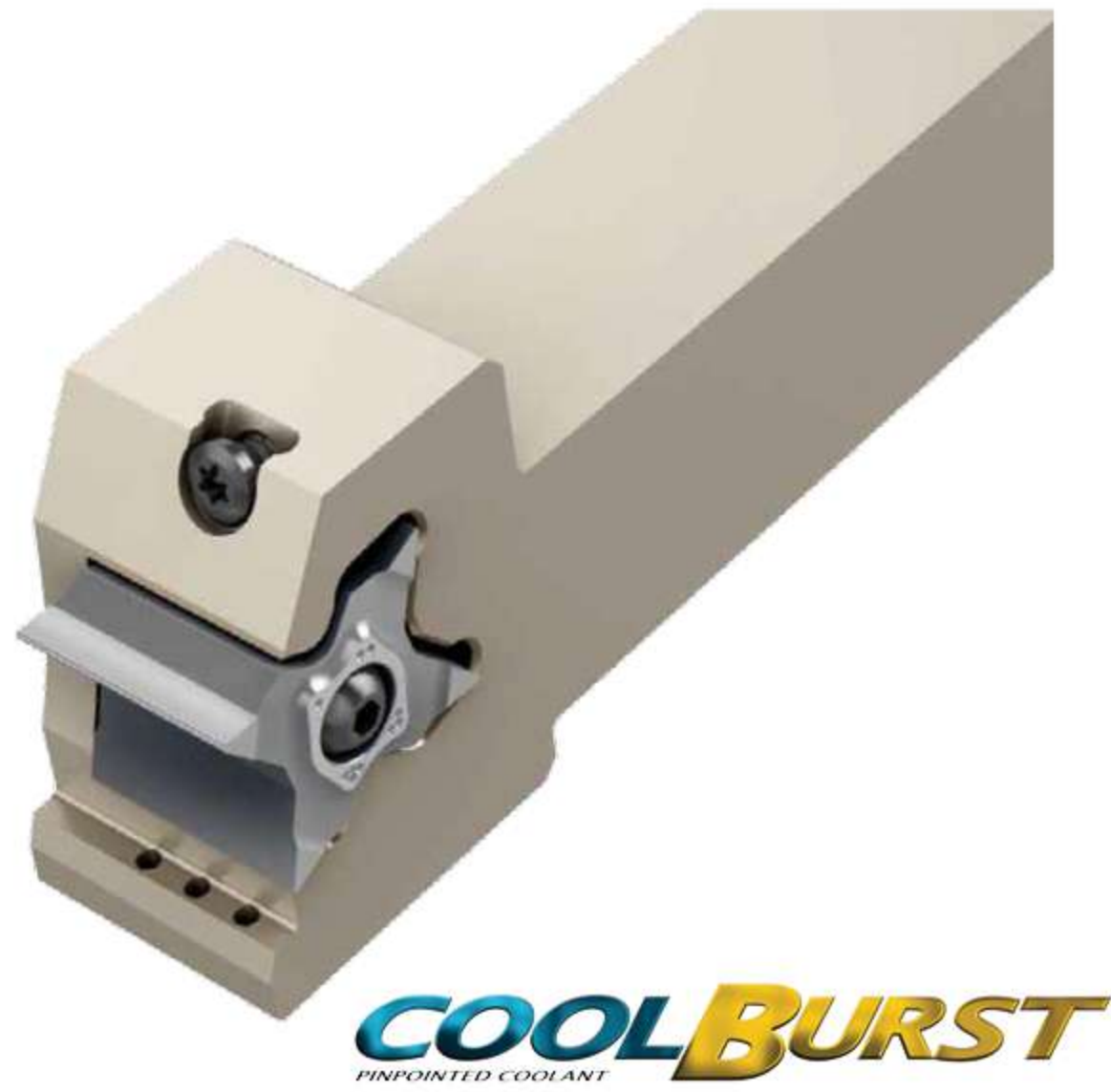

Fig.1

Fig.2
Right hand shown

Designation	Dimension (mm)						Fig.	CNT	Insert
	H(HF)	B	OAL	CW	HBH	HBKW			
TQHR/L 20-27-10EW-TB	20	20	120	10.5	13	-	1	G 1/8	TQBS 27-10EW
20-27-15EW-TB	20	20	120	15.5	13	-	1	G 1/8	TQBS 27-15EW
20-27-20EW-TB	20	20	120	20.5	13	5.0	1	G 1/8	TQBS 27-20EW
25-27-10EW-TB	25	25	135	10.5	8	-	2	G 1/8	TQBS 27-10EW
25-27-15EW-TB	25	25	135	15.5	8	-	2	G 1/8	TQBS 27-15EW
25-27-20EW-TB	25	25	135	20.5	8	-	2	G 1/8	TQBS 27-20EW

Spare parts

Designation	Clamping Pin	Pin Screw	Side screw	Plug	Wrench		
TQHR/L 20...10EW-TB	PIN-TQ-W-T	TS 40F120A	BH M4X0.7X16-D7	PLG G1/8-L6.5	T 15	L-W 2.5	L-W 5
TQHR/L 20...15EW-TB	PIN-TQ-W-T	TS 40F120A	BH M4X0.7X20-D7	PLG G1/8-L6.5	T 15	L-W 2.5	L-W 5
TQHR/L 20...20EW-TB	PIN-TQ-W-T	TS 40F120A	BH M4X0.7X23-D7	PLG G1/8-L6.5	T 15	L-W 2.5	L-W 5
TQHR/L 25...10EW-TB	PIN-TQ-W-T	TS 40F120A	BH M4X0.7X16-D7	-	T 15	L-W 2.5	-
TQHR/L 25...15EW-TB	PIN-TQ-W-T	TS 40F120A	BH M4X0.7X20-D7	-	T 15	L-W 2.5	-
TQHR/L 25...20EW-TB	PIN-TQ-W-T	TS 40F120A	BH M4X0.7X23-D7	-	T 15	L-W 2.5	-

TQBS 27



4 cutting edges with semi-finished blanks for wide grooving and profiling

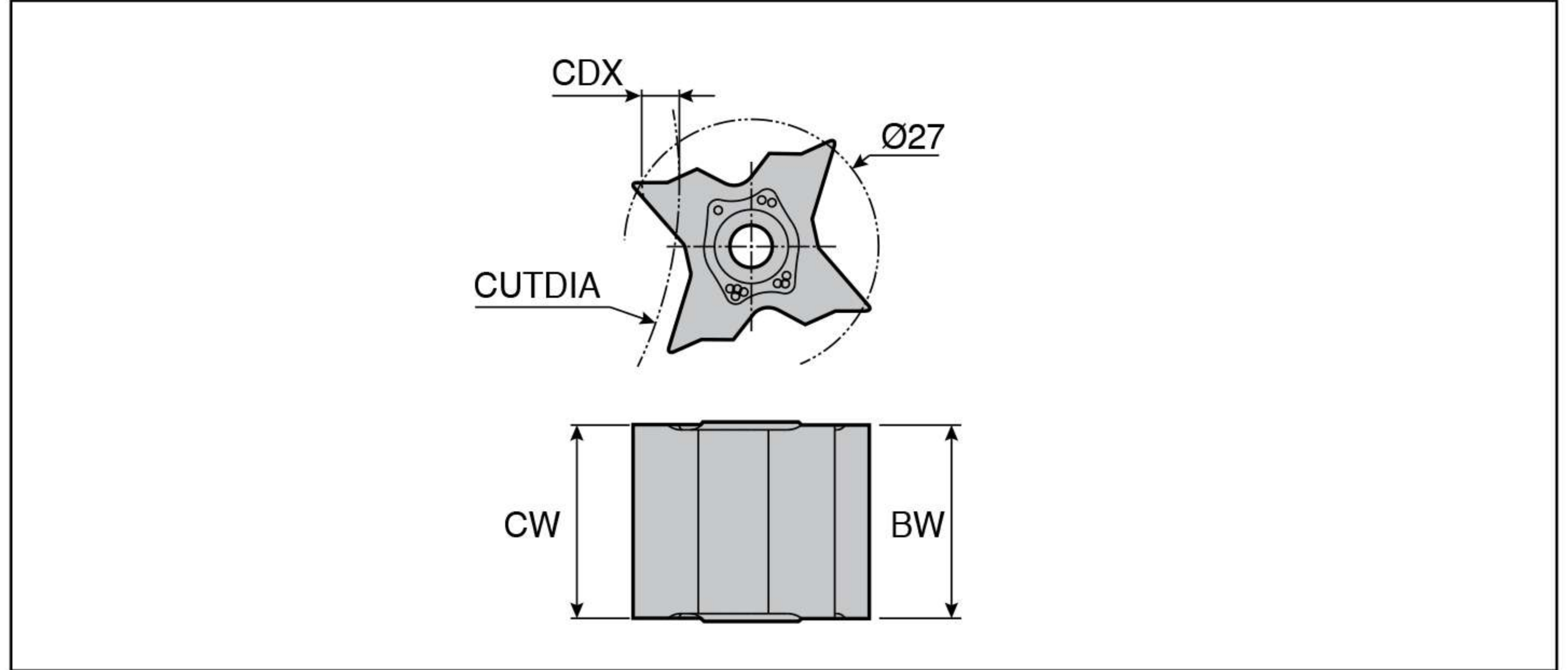
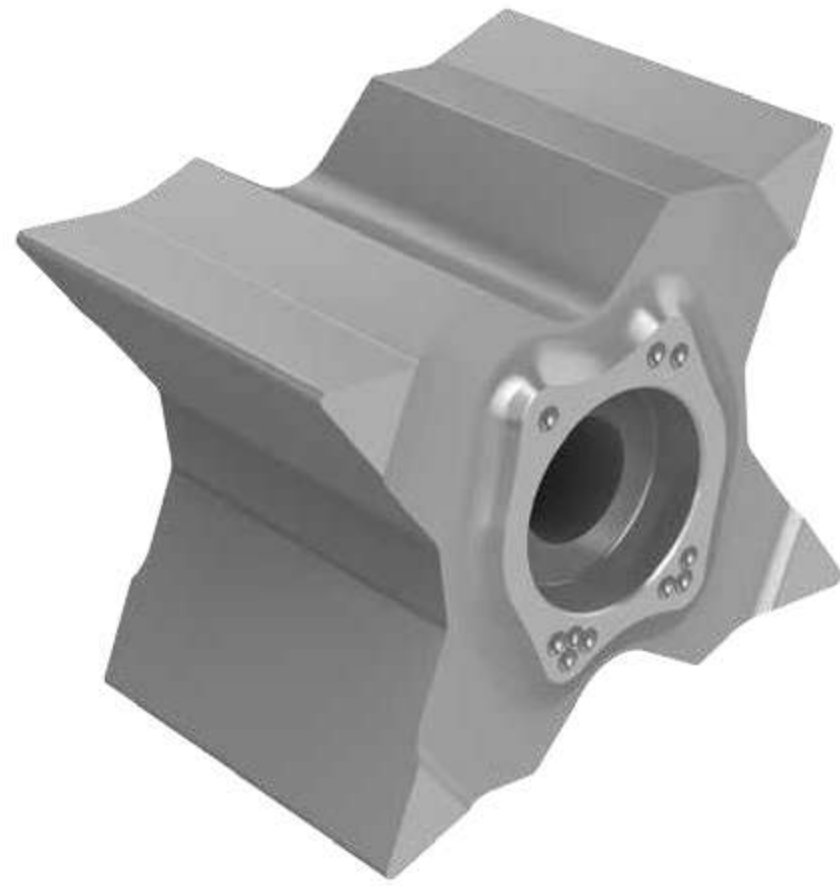

Designation	Dimension (mm)		CUTDIA										Grade
	CW	BW	CDX≤3.0	CDX≤3.5	CDX≤4.0	CDX≤4.5	CDX≤5.0	CDX≤5.5	CDX≤5.7	CDX≤6.0	CDX≤6.2	CDX≤6.4	UF10
TQBS 27-10EW	10.5	11.1	N.L.	600	280	180	135	105	95	85	78	55	●
27-15EW	15.5	16.1	N.L.	600	280	180	135	105	95	85	78	55	●
27-20EW	20.5	21.1	N.L.	600	280	180	135	105	95	85	78	55	●

► N.L.: No limit

●: Standard items

CONTACT US



MEGA TECH METALWORK CO.,LTD (Headquarter)



Tel : 02-943-1591



Fax : 02-943-1592



Line ID : @mgt_metalwork



Email : sales.m@mgtg.co.th



Web : <https://www.mgtg.co.th/>



**17/4 Soi Ramintra 89
Ramintra Khannayao
Bangkok 10230**

