

NEW PRODUCT NEWS



Taegutec Parting & Grooving Line

QUADIRUSH INTERNAL GROOVING

**RIGIDITY ENHANCED BORING BARS FOR
INTERNAL GROOVING AND TURNING**



KEY POINT

TaeguTec has added reinforced boring bars to the QUAD-I-RUSH family.

The QUAD-I-RUSH family now includes rigidity enhanced boring bars, extending the range's capabilities. The new line is available in 16, 20, 25 and 32 mm diameters, and includes more shank sizes than the current 16 and 20 mm diameters. With the rigidity enhanced boring bars, machining reliability, surface roughness and productivity have been improved.

Features

- Higher feed capability for increased productivity
- Improved machining reliability
- Good surface roughness
- Available shank sizes: Ø16, 20, 25, 32 mm.

TQHIR 20-16.5-14

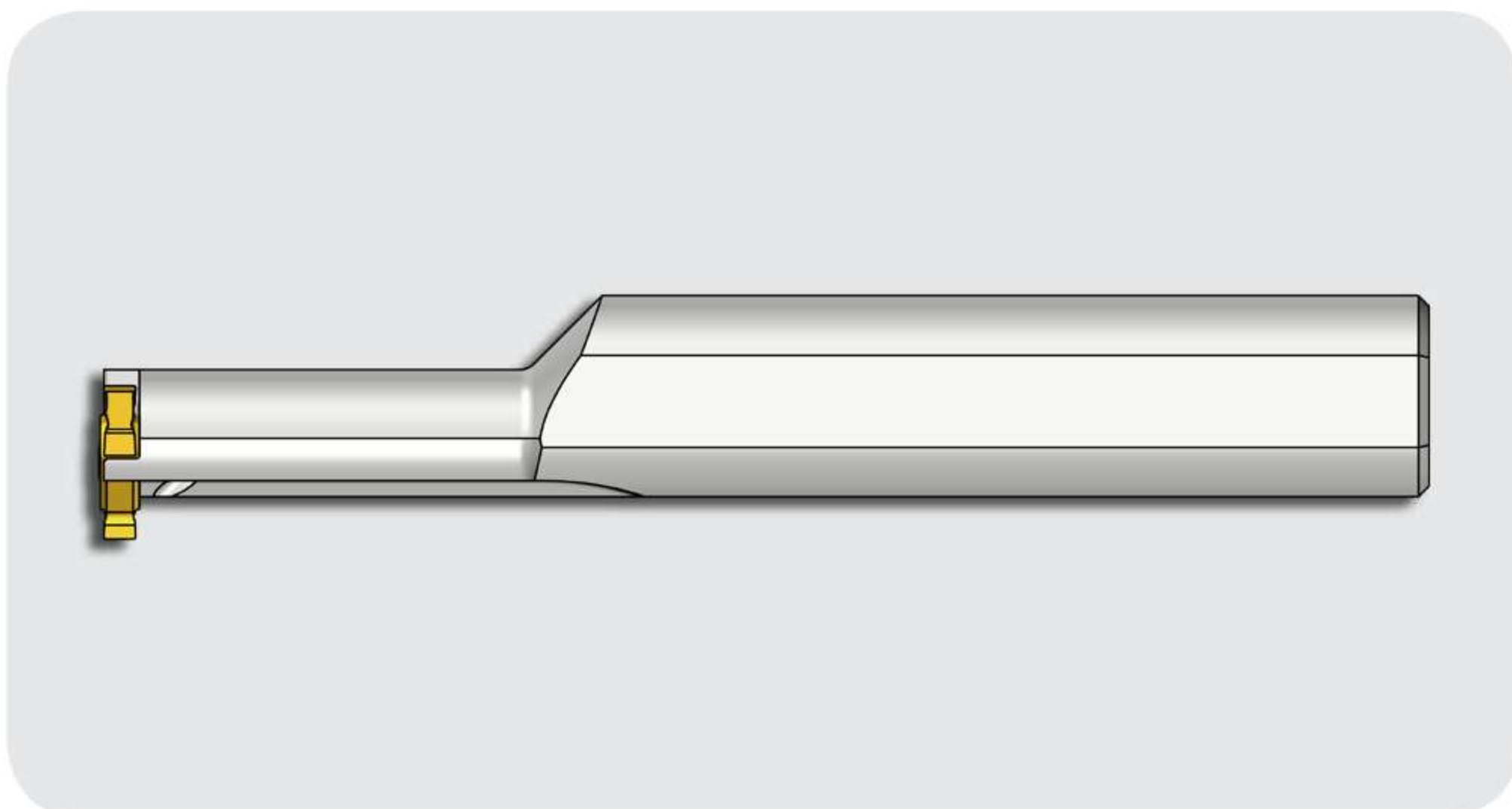

TQHIR 20-24-14 **new**

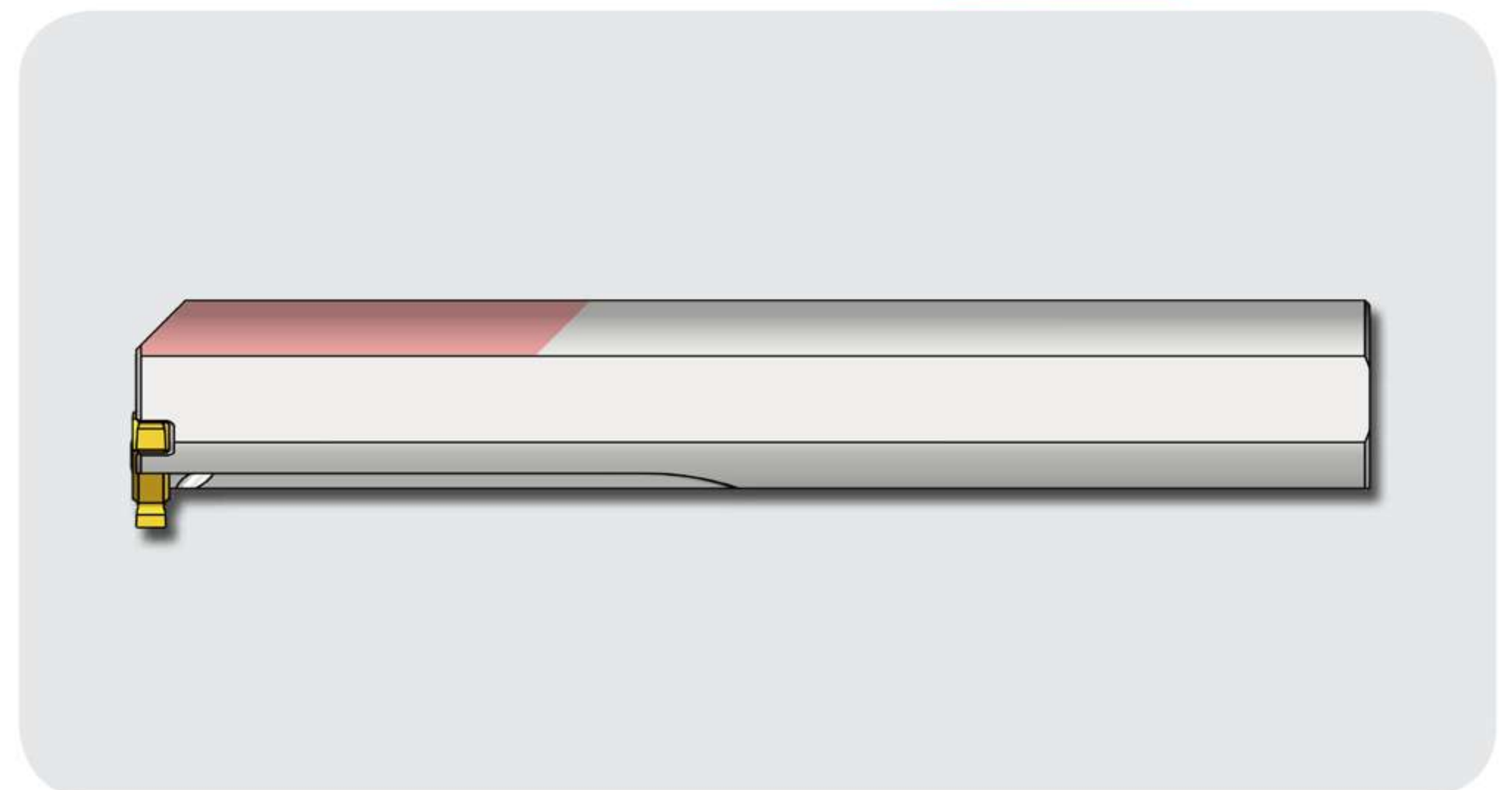

TQHIR/L



Internal boring bars for shallow grooving with coolant hole

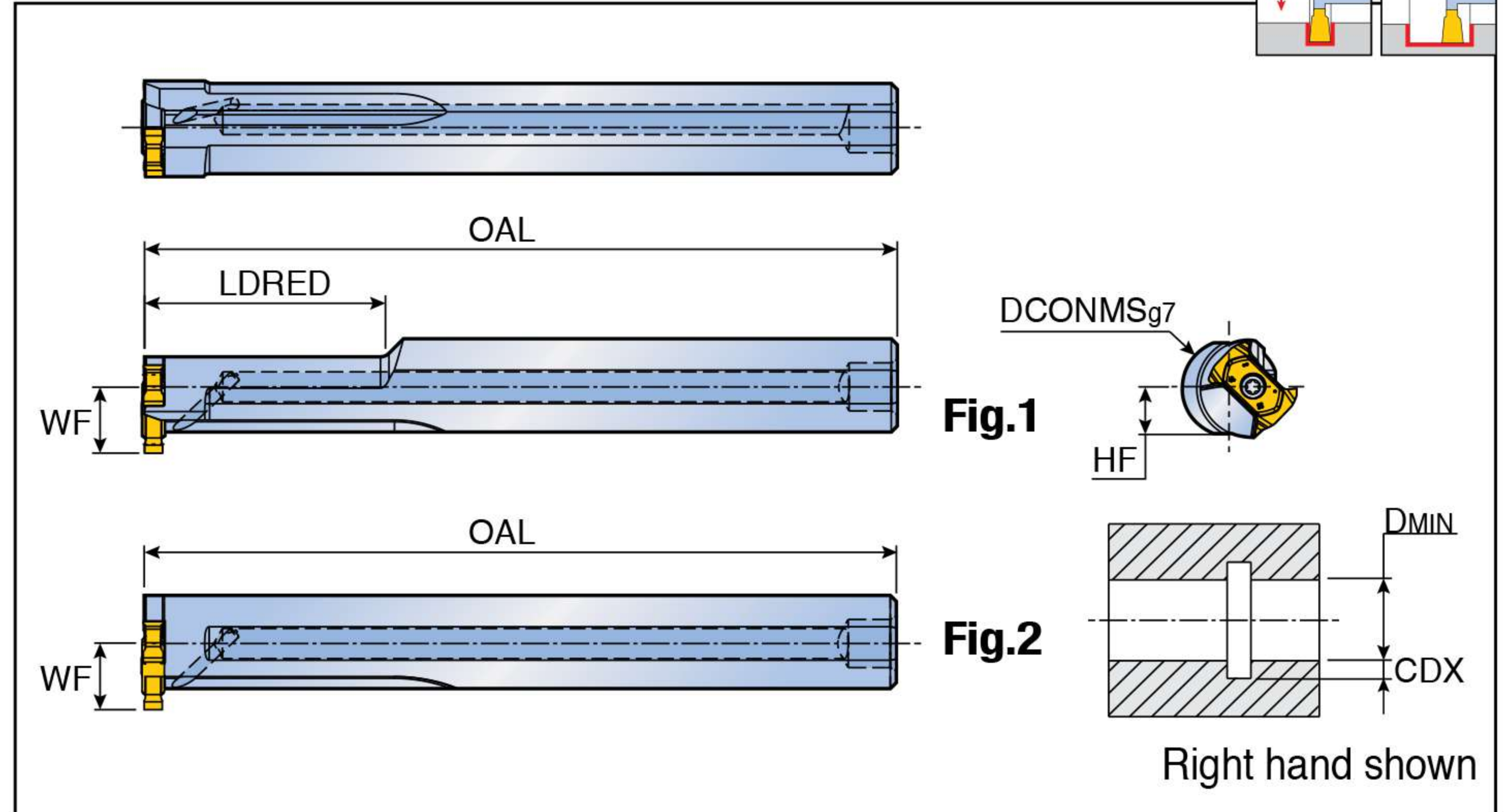

Designation	Dimension (mm)						Fig.	Insert
	DCONMS	OAL	LDRED	WF	DMIN	HF		
TQHIR/L 16-16.5-14	16	125	40	11	16.5	7.5	1	TQIS 14
20-16.5-14	20	125	40	13	16.5	9	1	
16-20-14 new	16	125	-	11	20	7.5	2	
20-24-14 new	20	125	-	13	24	9	2	
25-29-14 new	25	200	-	15.5	29	11.5	2	
32-36-14 new	32	200	-	19	36	15	2	

• CDX: Refer to the insert dimension

Spare parts

Designation	Screw	Wrench	Seal	
TQHIR/L 16	TS 25075I/HG	T 8	PL 16 (M6)	
TQHIR/L 20	TS 25075I/HG	T 8	PL 20 (M6)	
TQHIR/L 25	TS 25075I/HG	T 8	PL 25 (R1/8")	
TQHIR/L 32	TS 25075I/HG	T 8	PL 32 (R1/8")	

CONTACT US



MEGA TECH METALWORK CO.,LTD (Headquarter)



Tel : 02-943-1591



Fax : 02-943-1592



Line ID : @mgt_metalwork



Email : sales.m@mgtg.co.th



Web : <https://www.mgtg.co.th/>



**17/4 Soi Ramintra 89
Ramintra Khannayao
Bangkok 10230**

