

NEW PRODUCT NEWS



Taegutec Turning Line

RHINO TURN

**DNGX-ST INSERT
FOR DEEP DEPTH OF CUT MACHINING**



KEY POINT

TaeguTec's RHINO-TURN line now includes the DNGX-ST insert for deep depth of cut machining.

Compatible with RHINO turning holders, the 4-corner negative DNGX-ST insert with a high rake angle designed new chip breaker provides excellent machining performance and stable tool life due to the low cutting force generated during machining. The new chip breaker enables deep depth of cut machining up to 5.0 mm so that the number of required machining paths is reduced, resulting in higher productivity.

For further details, please contact the relevant product manager.

Features

- 4-corner double-sided insert
- 5.0 mm maximum depth of cut
 - Reduced number of machining paths for higher productivity
- **Continuous chip ensures low cutting force and a precise machining dimensions**
- Recommended for use with the servo oscillation function in Swiss type machines
- Higher rake angle design for low cutting force
- Compatible with RHINO turning holders

DNGX-ST insert's hand type

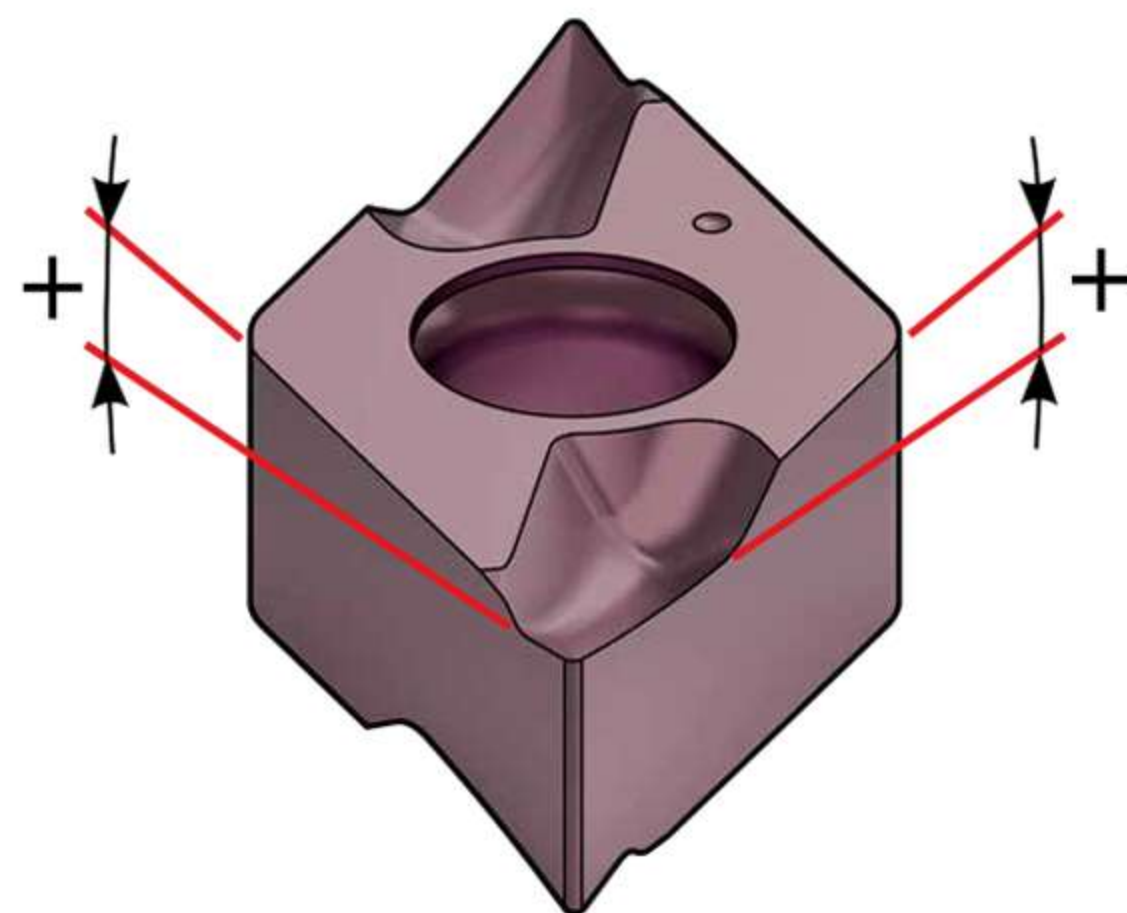

DNGX 130502M-ST-R
Right hand insert



P/S/T/HDJNR...1305(-TB)
Right hand holder

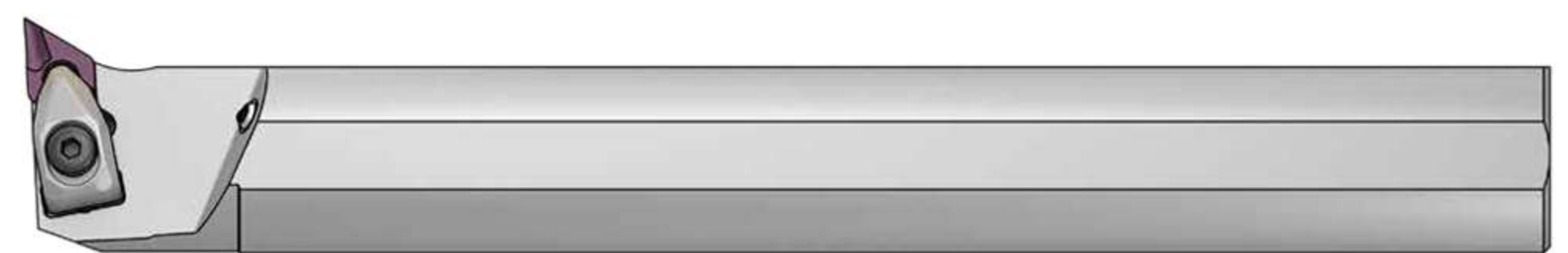

A-T/HDUNL...1305
Left hand boring bar

DNGX-ST cutting edge on the holder

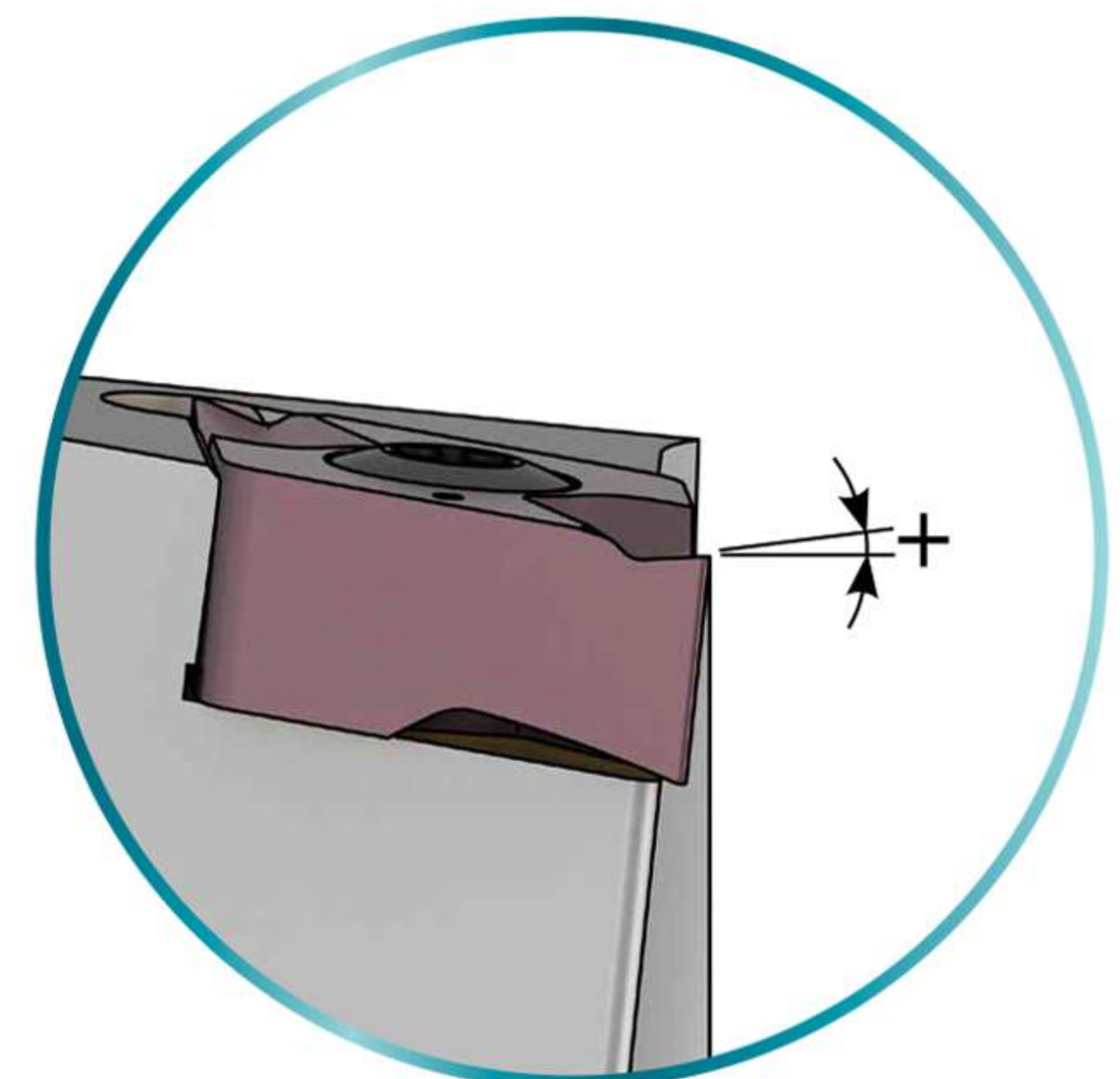
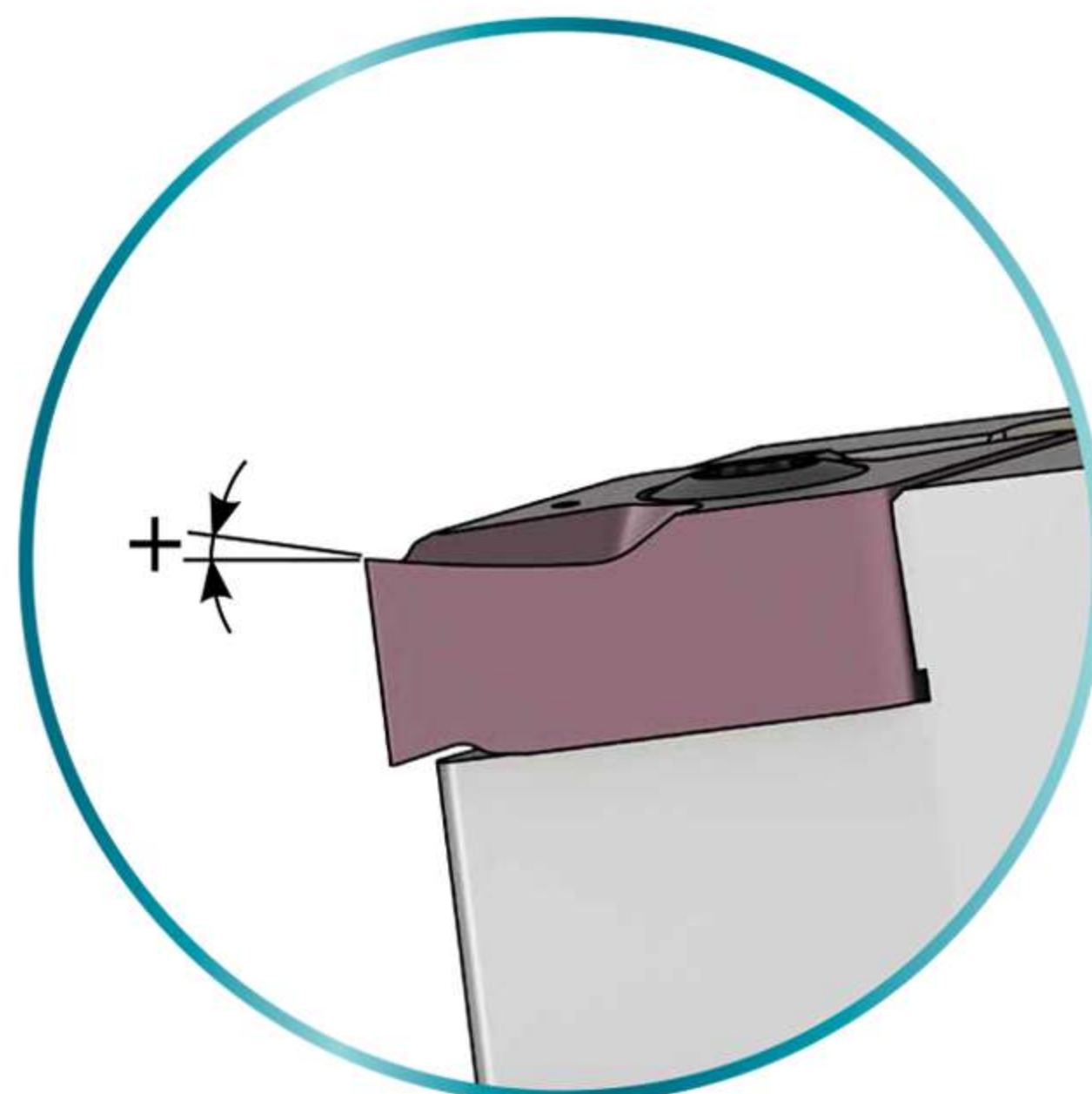
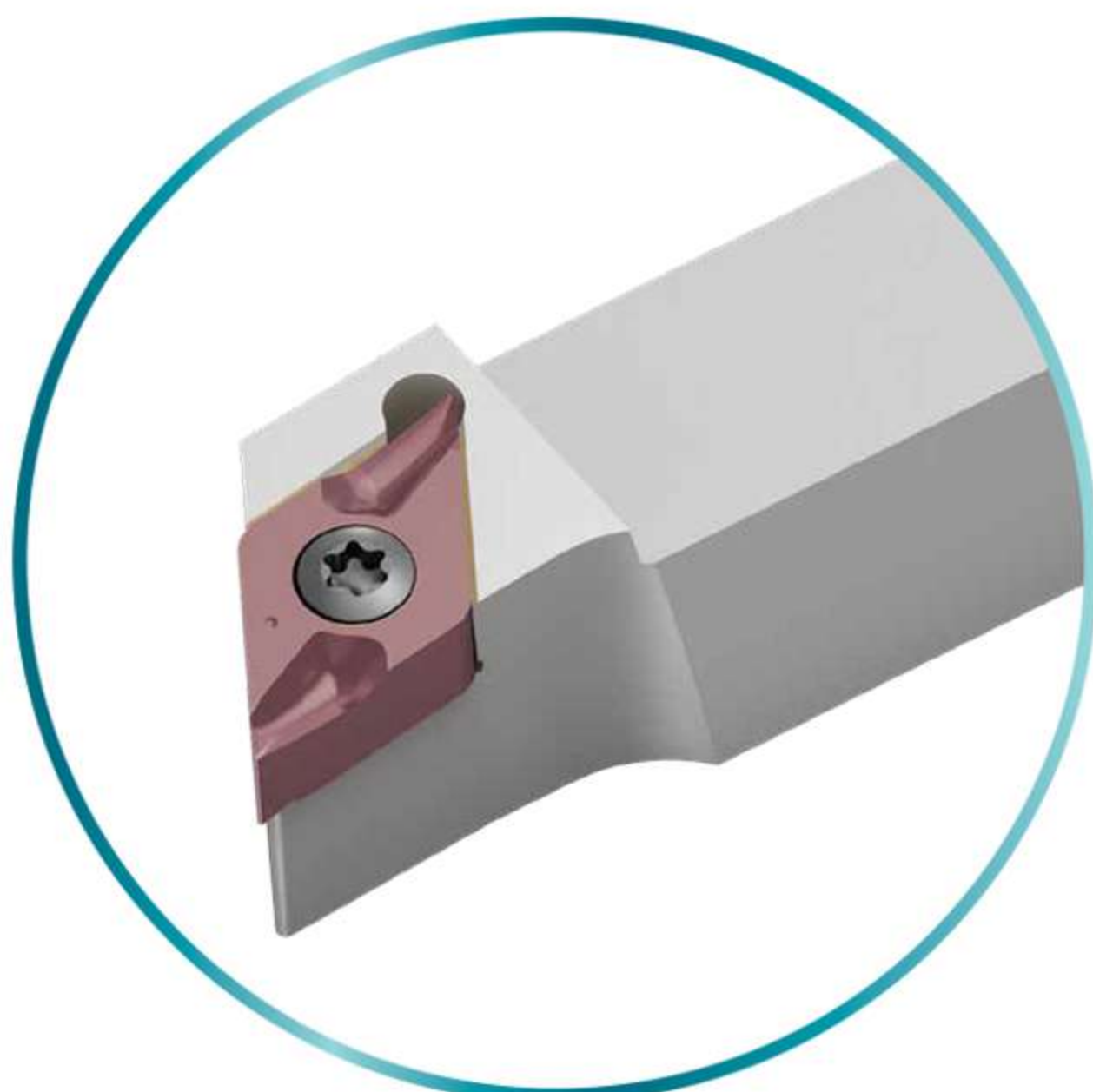

DNGX-ST insert geometry

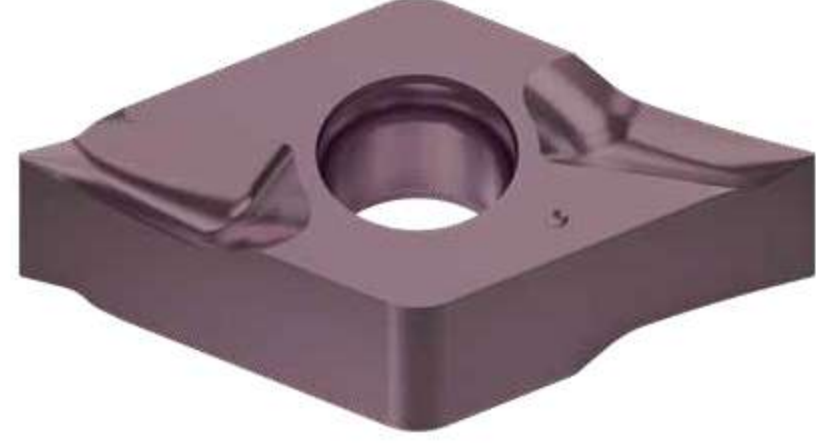
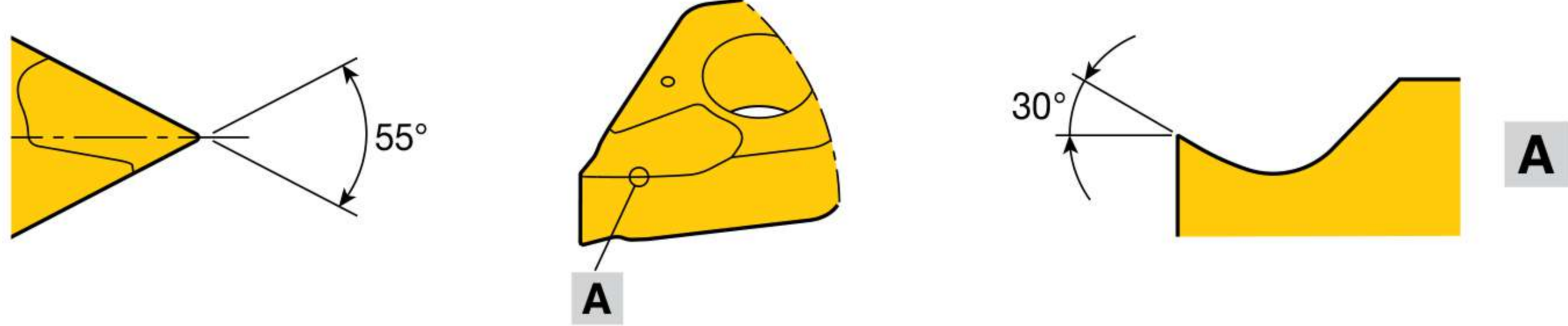
Chip breaker	Geometry
 <p>ST: for roughing</p>	

Chip breaker range

Depth of cut (mm)

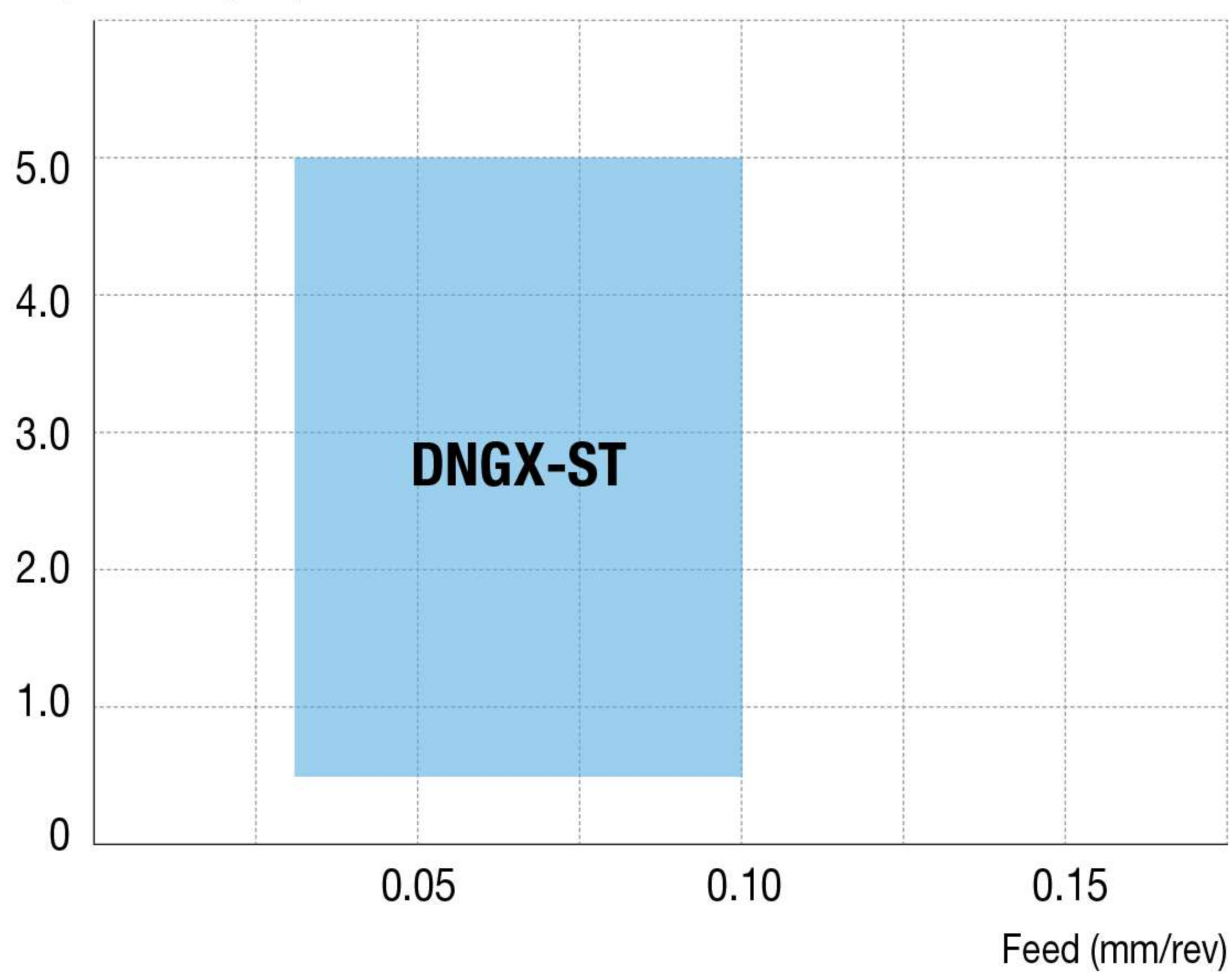









- ▶ Insert: DNGX 130502M ST-R-E
- ▶ Cutting speed (V): 125 m/min
- ▶ Material: S45C (HB180-220)

Taegutec Turning Line

Chip curl by cutting conditions

-Excellent chip control even in deep depths of cut up to 5.0 mm

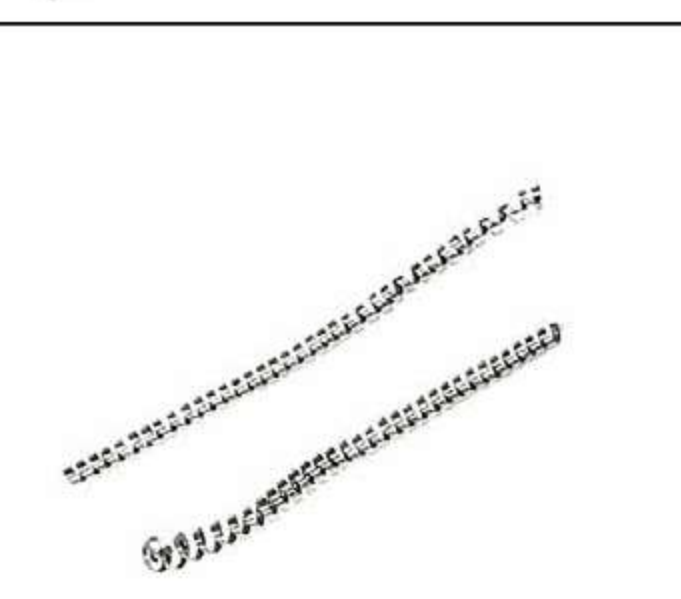
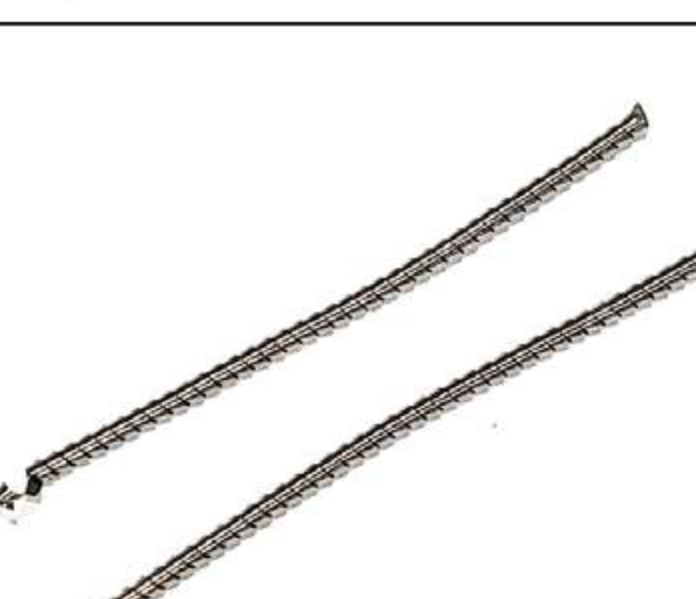
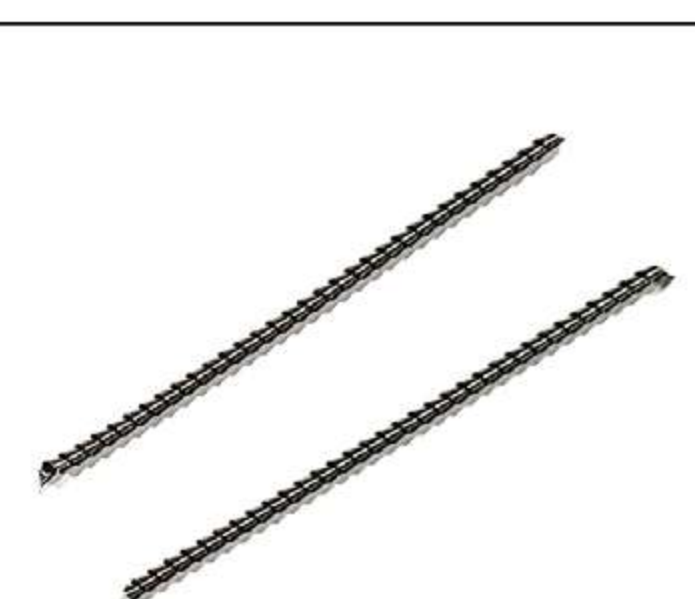
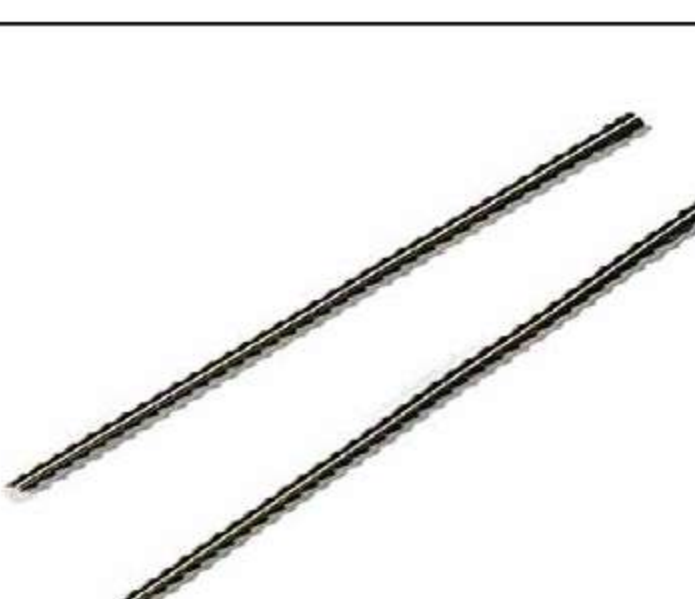
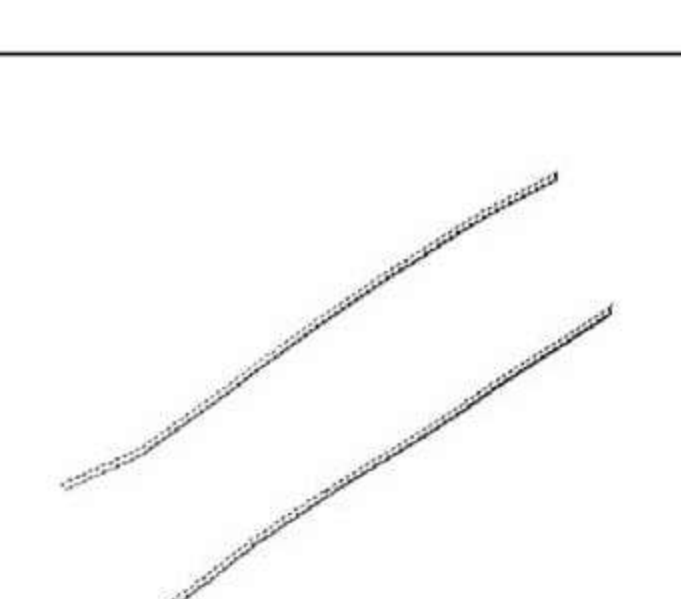
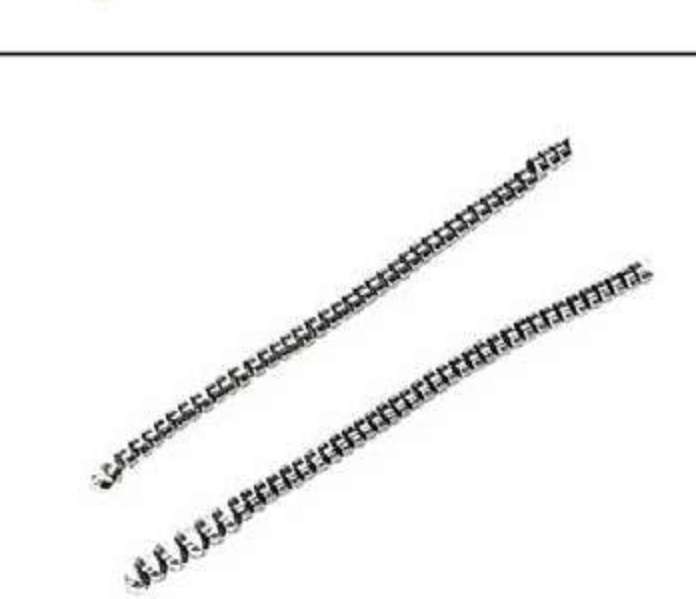
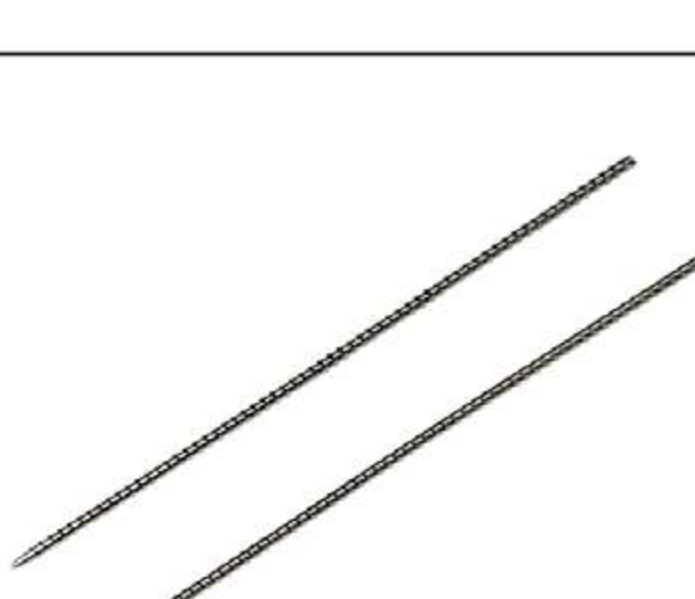
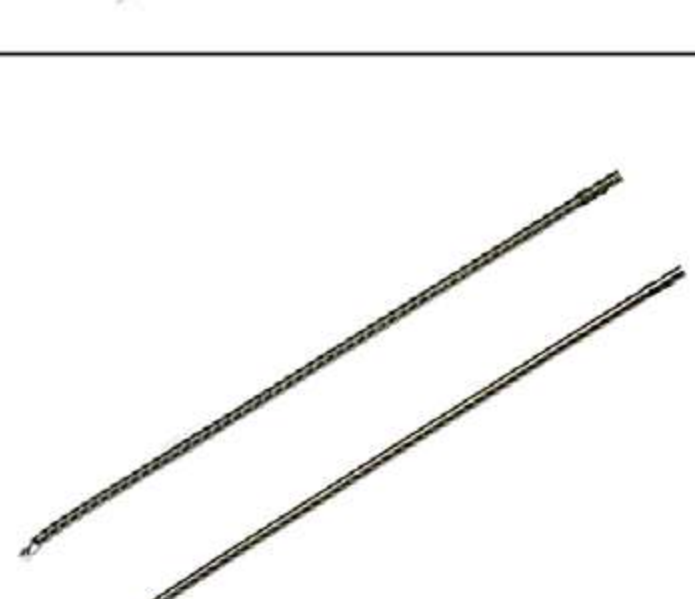
Material	Carbon Steel (AISI 1045)	Application	Ø20 external turning	RPM	2,000 rpm
ap (mm)	Feed (mm/rev)				
	0.03	0.05	0.08	0.1	
5.0					
3.0					
2.0					
1.0					

DNGX-ST new



Negative 55° rhombic inserts

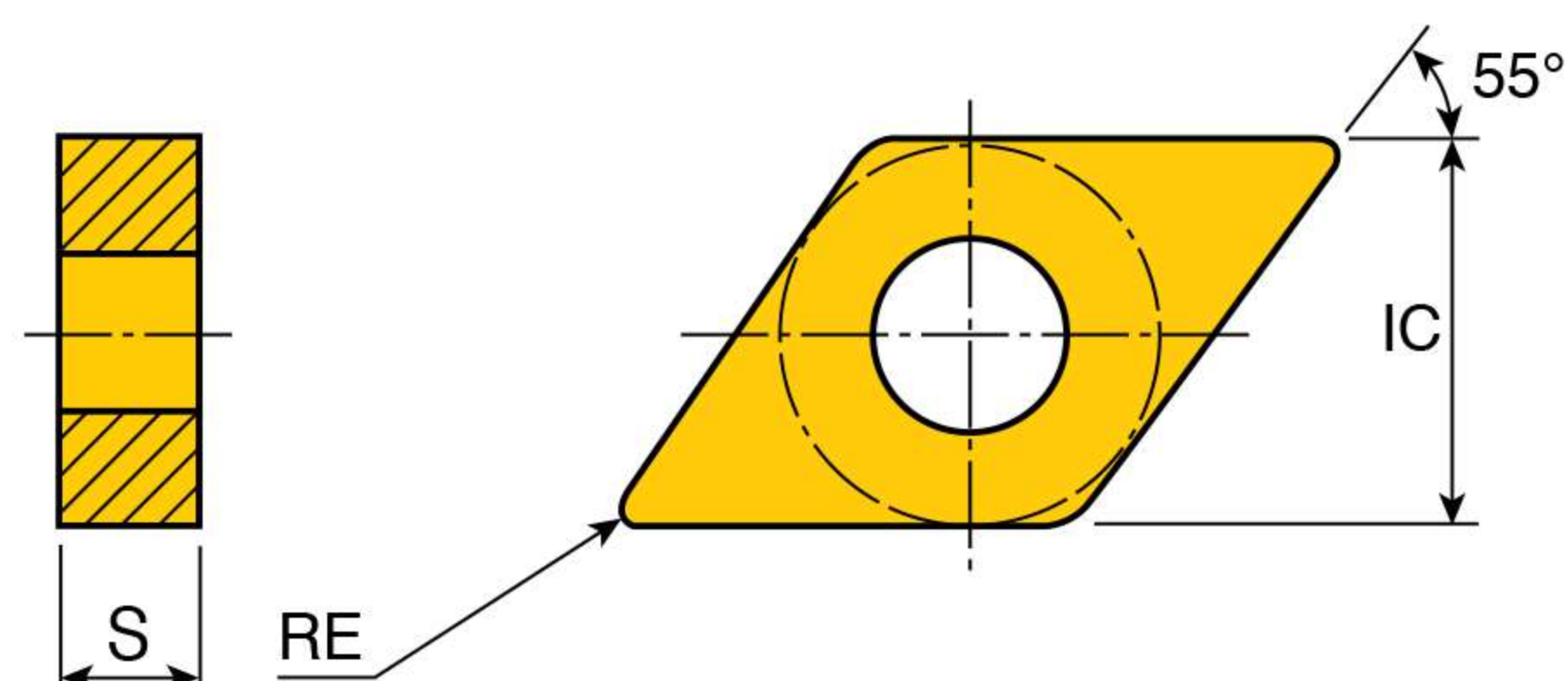

Size	Dimension (mm)		
	IC	S	RE
13	11.11	5.56	0.1-0.4

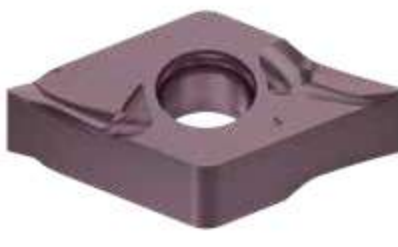
Insert	Designation	ap (mm)	Feed (mm/rev)	Material																				
				Cermet		CVD coated								PVD coated										
				PV3010	CT3000	TT3005	TT7005	TT7015	TT7025	TT8105B	TT8115B	TT8125B	TT8135B	TT9215	TT9225	TT9235	TT5100	TT7100	TT5080	TT3010	TT3020	TT9020	TT4410	TT4430
  Roughing For Swiss	DNGX 130501M ST-R-E	0.3-5.0	0.03-0.08																				●	
	130502M ST-R-E	0.5-5.0	0.03-0.10																					●
	130504M ST-R-E	0.7-5.0	0.05-0.12																					●
	130501M ST-R-F	0.3-5.0	0.03-0.08																	●				●
	130502M ST-R-F	0.5-5.0	0.03-0.10																	●				●
	130504M ST-R-F	0.7-5.0	0.05-0.12																	●				●

- ▶ M: Corner radius minus tolerance
- ▶ -R: Right hand insert
- ▶ -E: Micro honing edge
- ▶ -F: Sharp edge

●: Standard items

CONTACT US



MEGA TECH METALWORK CO.,LTD (Headquarter)



Tel : 02-943-1591



Fax : 02-943-1592



Line ID : @mgt_metalwork



Email : sales.m@mgtg.co.th



Web : <https://www.mgtg.co.th/>



**17/4 Soi Ramintra 89
Ramintra Khannayao
Bangkok 10230**

