

NEW PRODUCT NEWS

**MEGA
TECH**
METAL WORK CO.,LTD

Taegutec Turning Line

WINTURN
ADVANCED MACHINING

TaeguTec
WINSPEED
ADVANCED MACHINING

**6-CUTTING EDGE TNMV INSERT AND
HOLDERS FOR ALL-DIRECTIONAL TURNING**

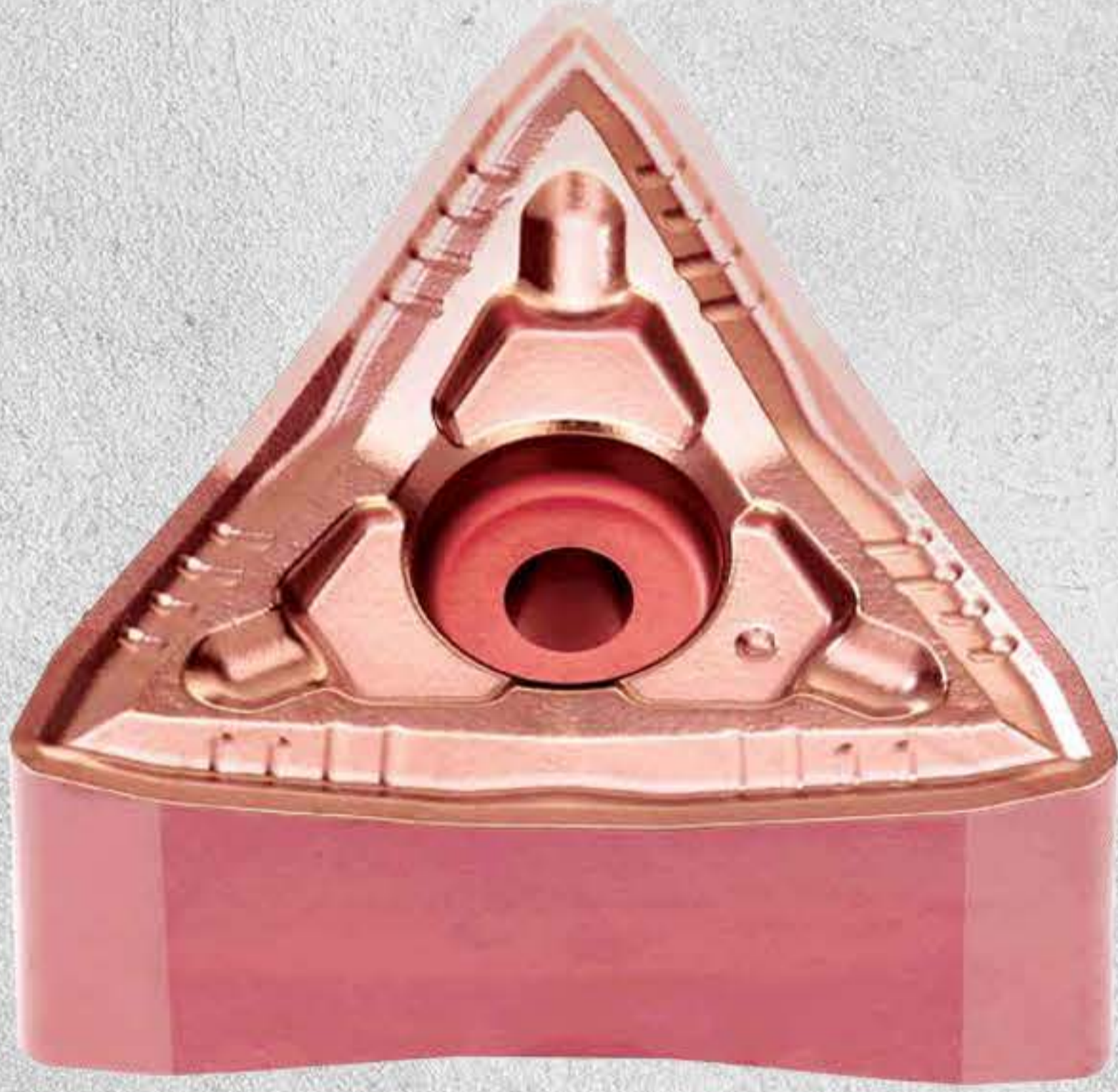

ADVANCECUTTING
TaeguTec

TaeguTec
Member IMC Group

KEY POINT

TaeguTec launches the 6-corner TNMV inserts and holders with the all-directional turning WIN-TURN line.





The 6-corners, 80 degree angle TNMV is a multidirectional, high productivity line capable of deep depth of cuts in forward turning and high feed rates in backwards turning operations. The holders, which use the strong clamping T-HOLDER design, are capable of longitudinal and face turning, both forward turning and backwards turning operations, all in one tool.

For further information, please contact the product manager.

Features

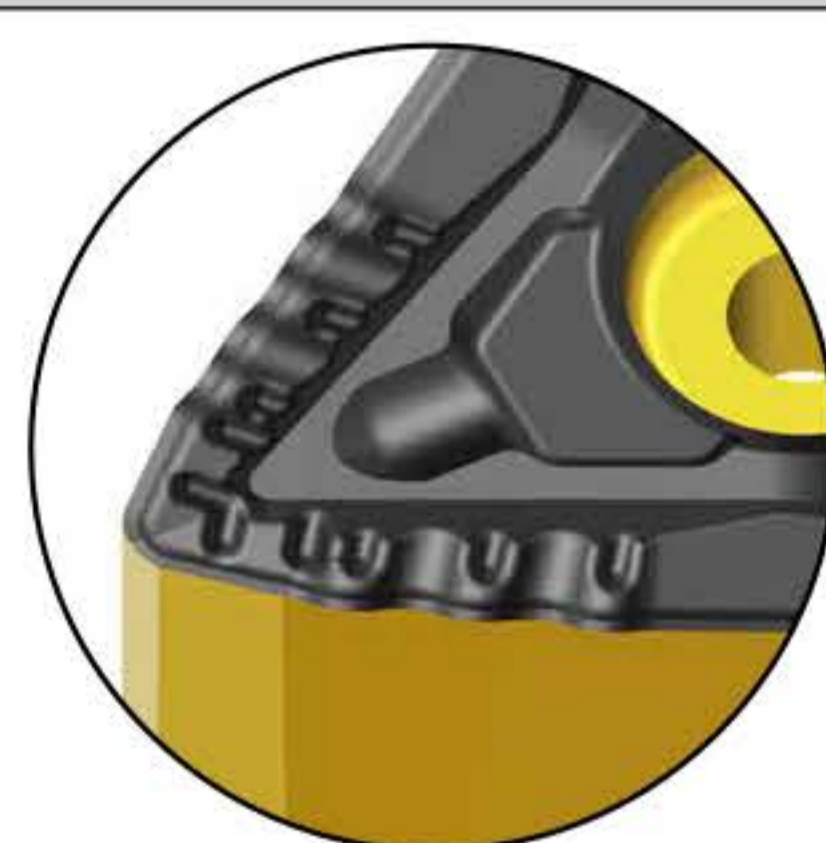
- Double-sided, 6-corners negative inserts with an 80-degree corner angle
- Same low cutting force as a positive type insert when mounted to holders
- Multidirectional turning without exchanging the tool holder
 - Higher productivity due to reduced downtime and reduced holder inventory
- Capable of deep depth of cut in forward turning: maximum 3.5 mm
- Capable of high feed backward turning: maximum 1.2 mm/rev
- The same T-HOLDER's simple clamping operation and strong clamping force
- High-pressure coolant supplying COOL-BURST holders are available as standard holders

WINTURN TNMV chip breakers

ISO	Chip breaker	
 For steel	BM	 
 For stainless ※Not recommended for super alloy	BS	 

Positive insert's cutting edge when mounted to the holder

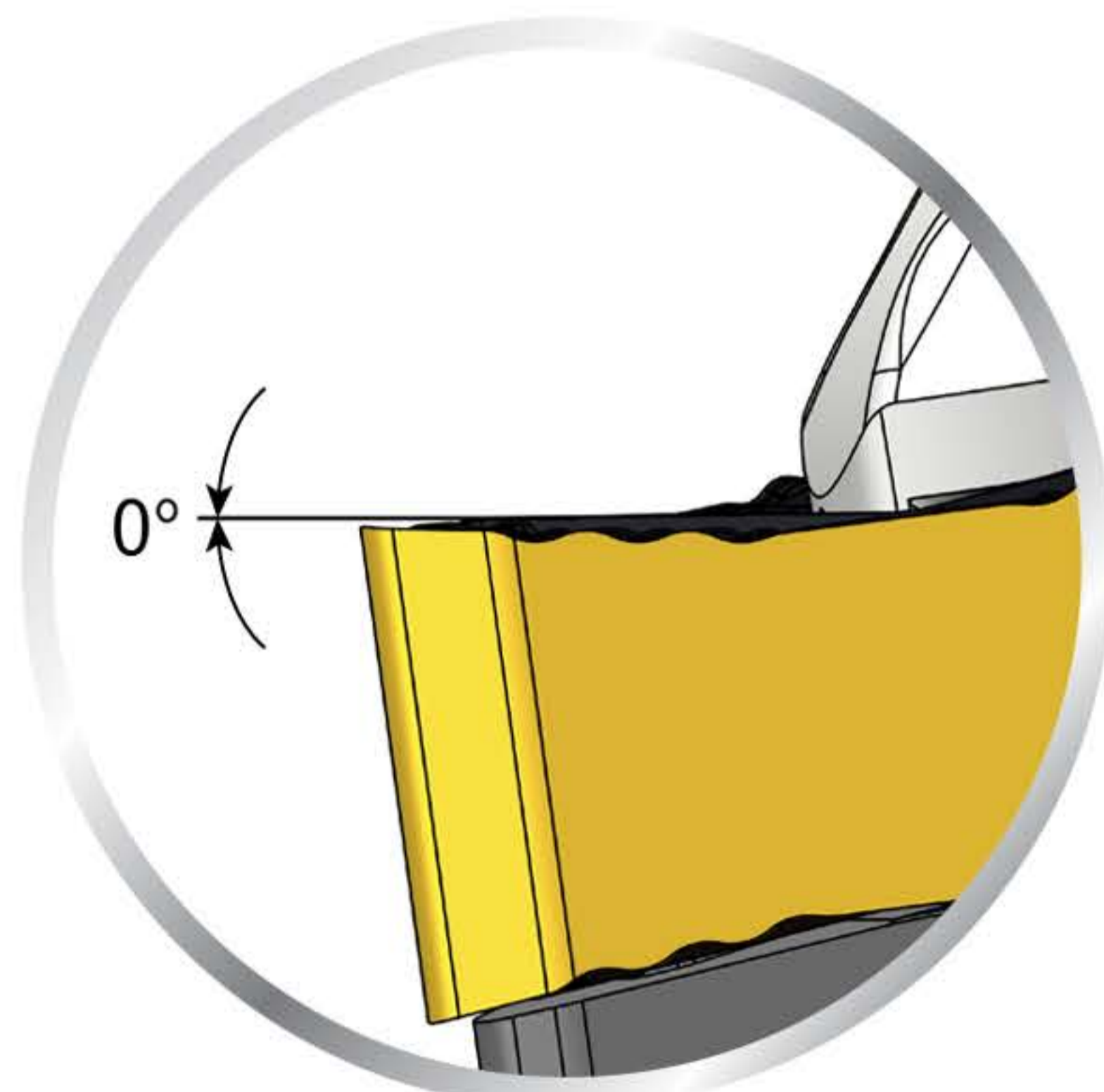

TNMV insert

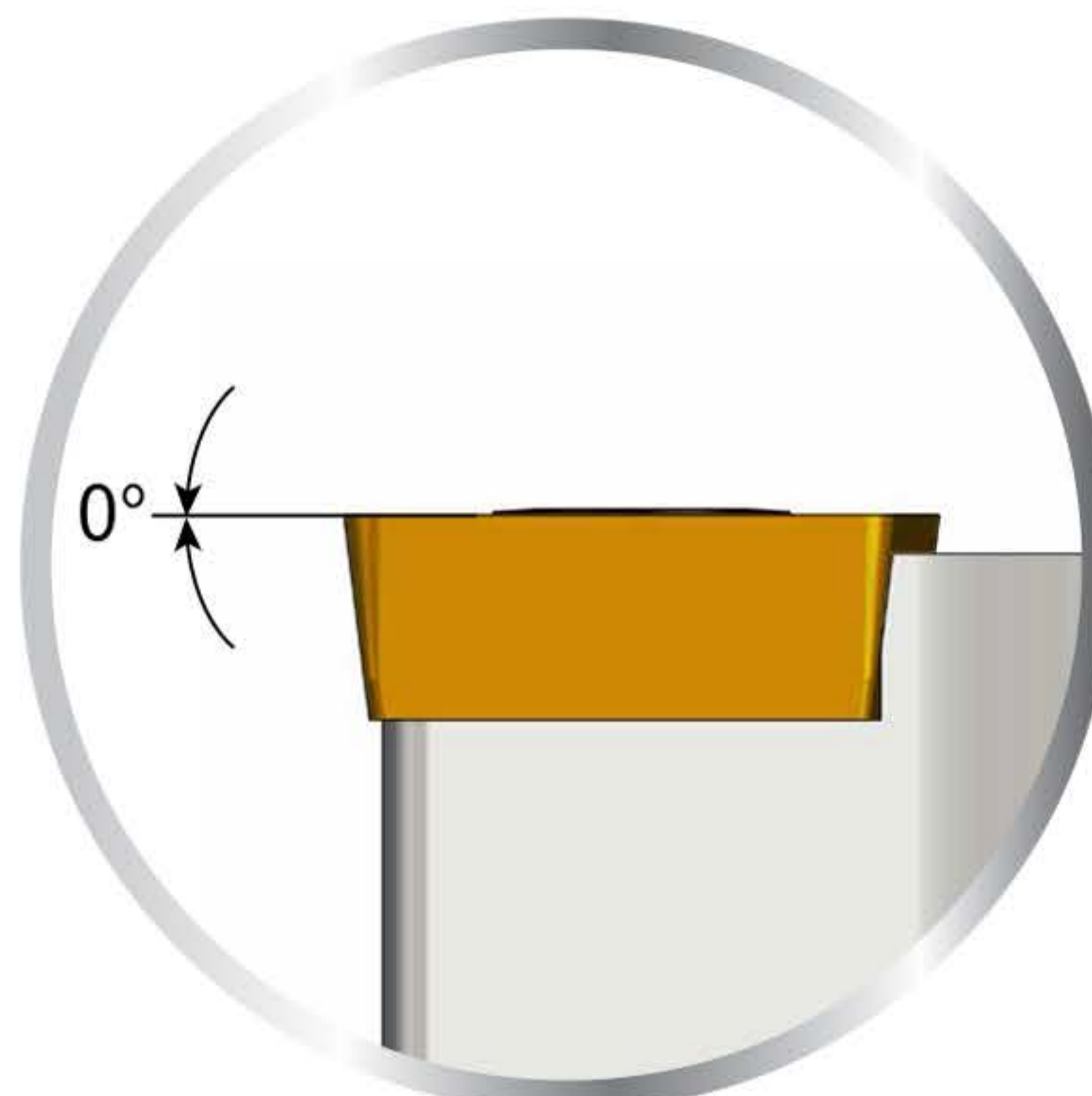

Standard positive insert

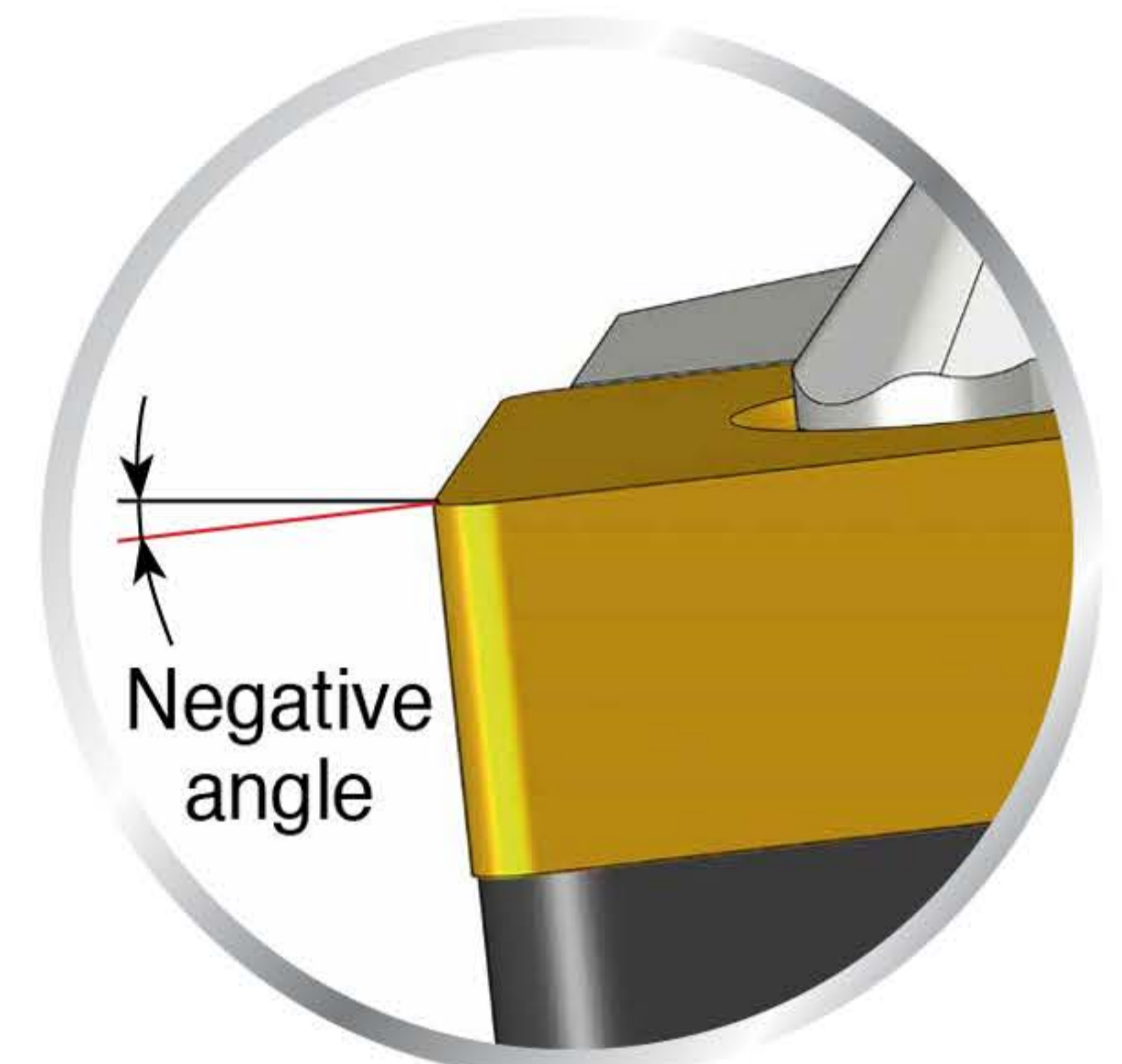

Standard negative insert

T-HOLDER clamping and unique assembly design

- Strong 2-directional clamping force

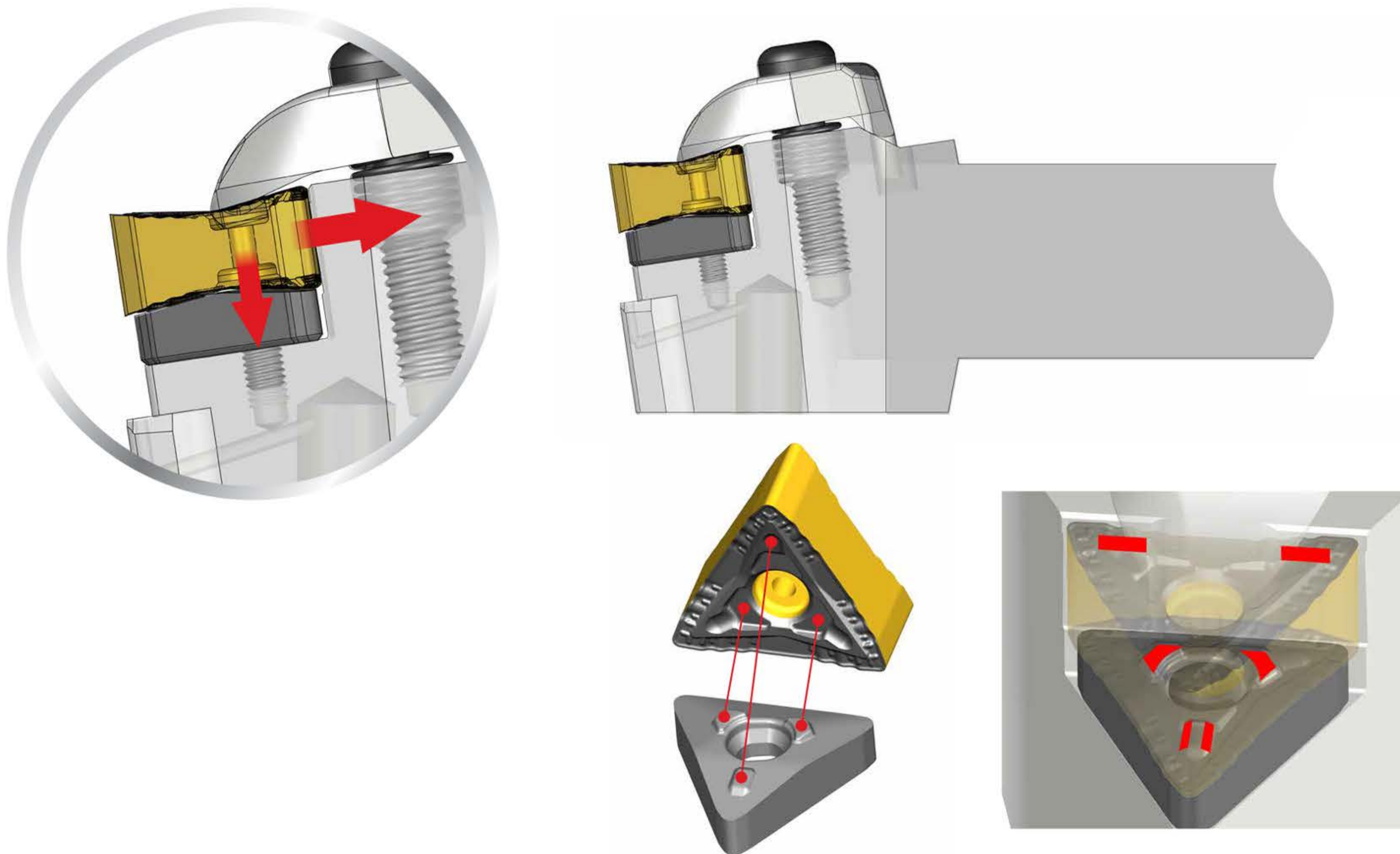

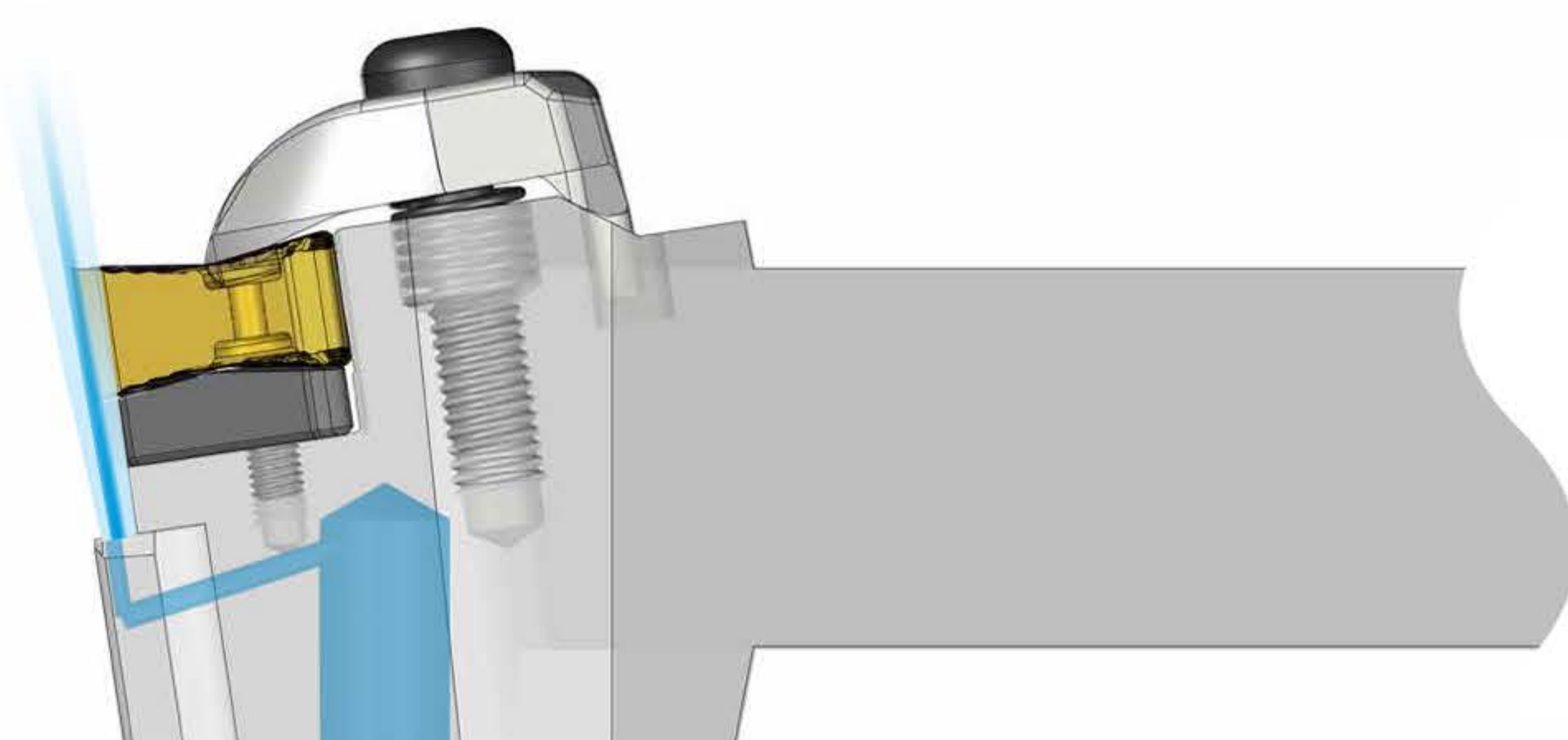

COOL-BURST high pressure coolant supply holder

- Stable and long tool life

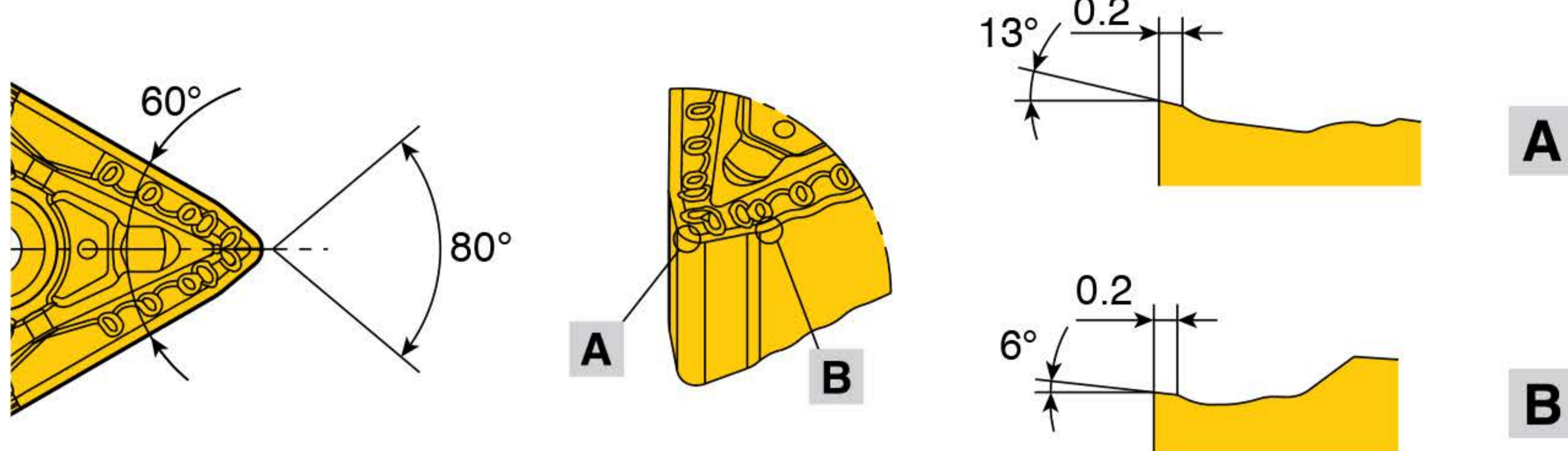

TNMV insert geometry

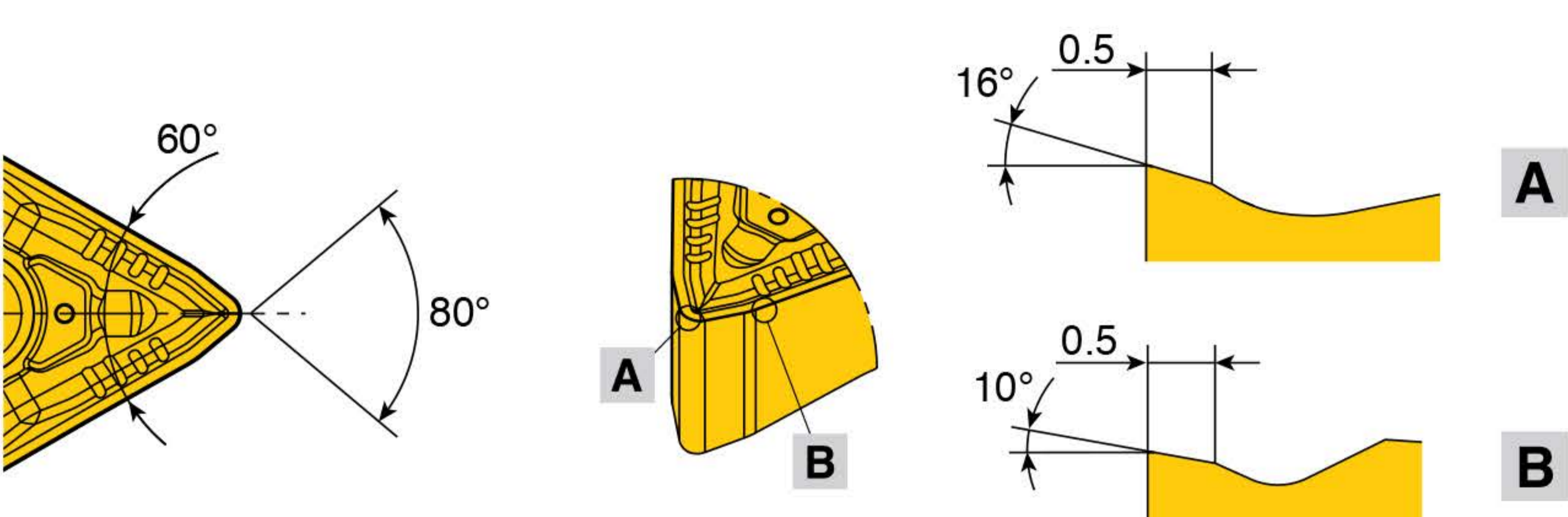
Chip breaker	Cutting edge geometry
 <p>BM: For steel</p>	
 <p>BS: For stainless steel ※ Not recommended for super alloy</p>	

TNMV recommended cutting conditions

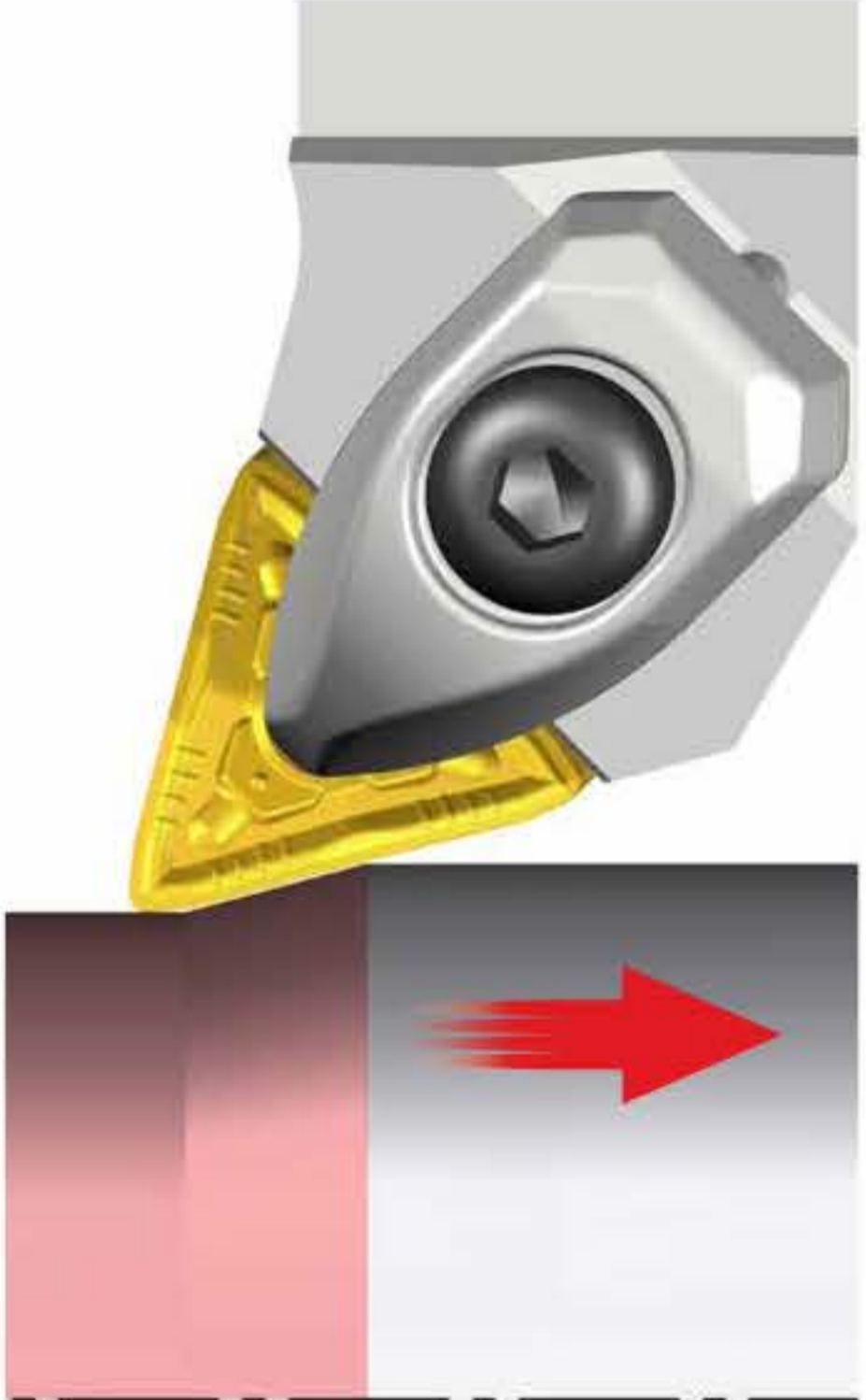
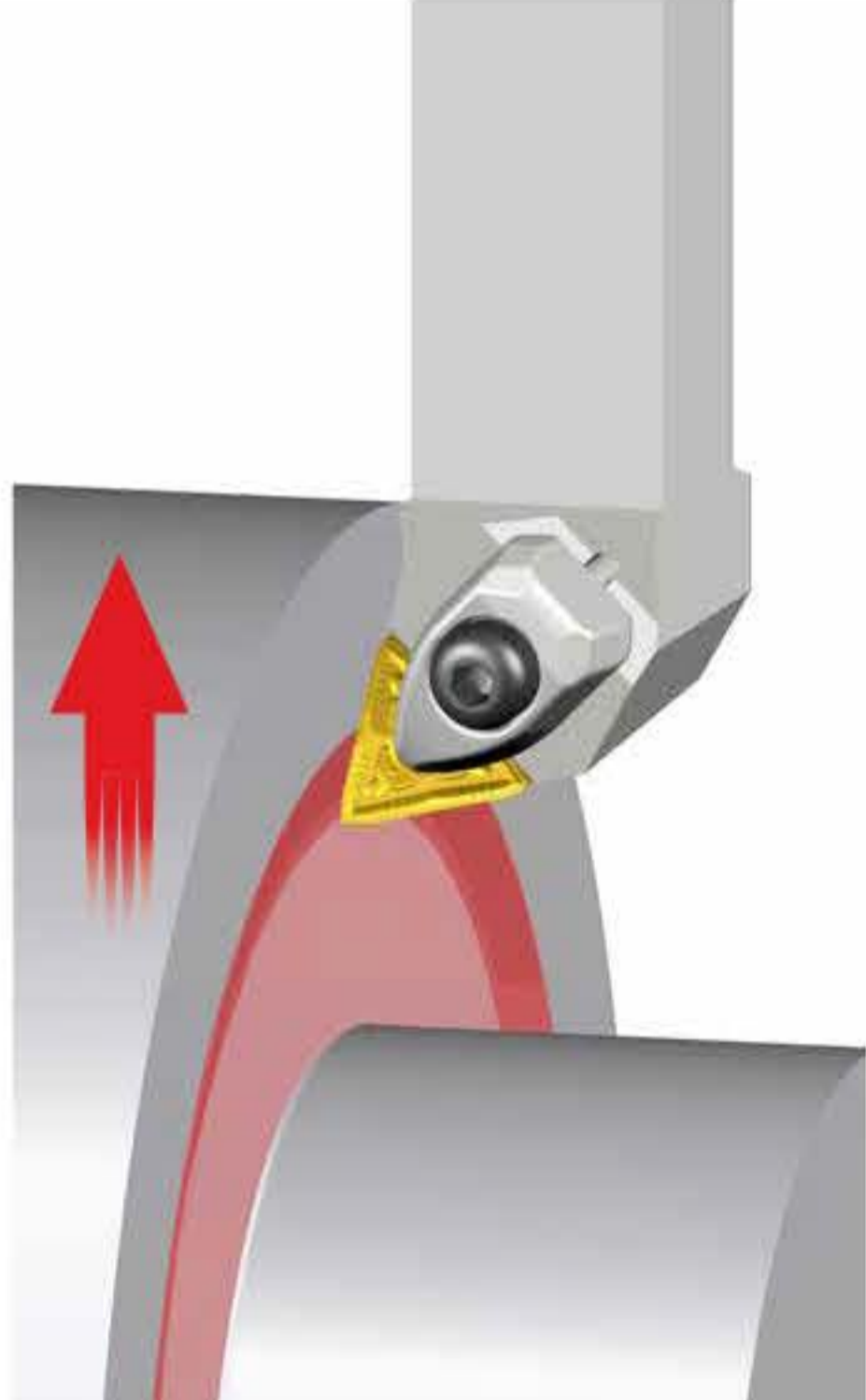
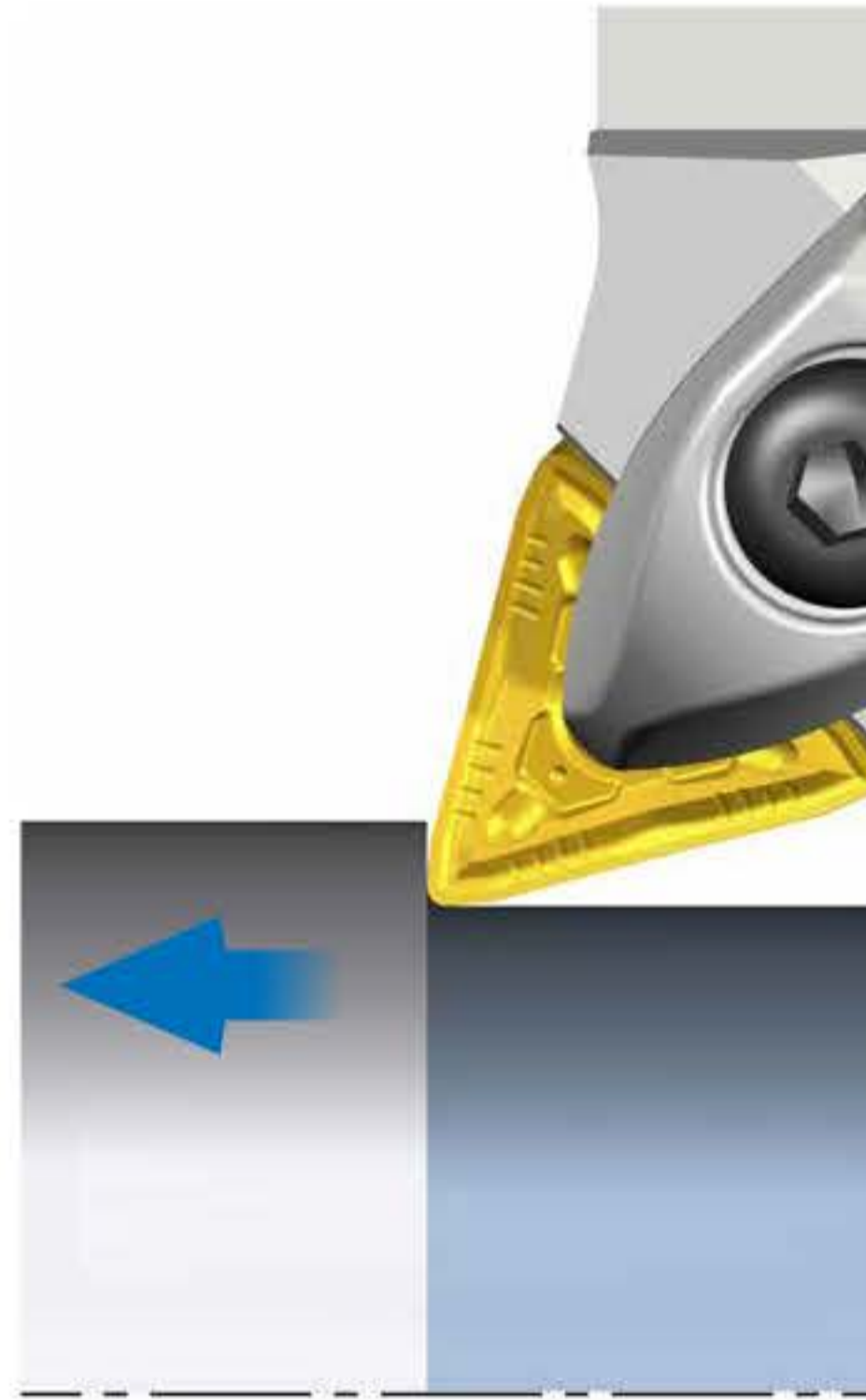
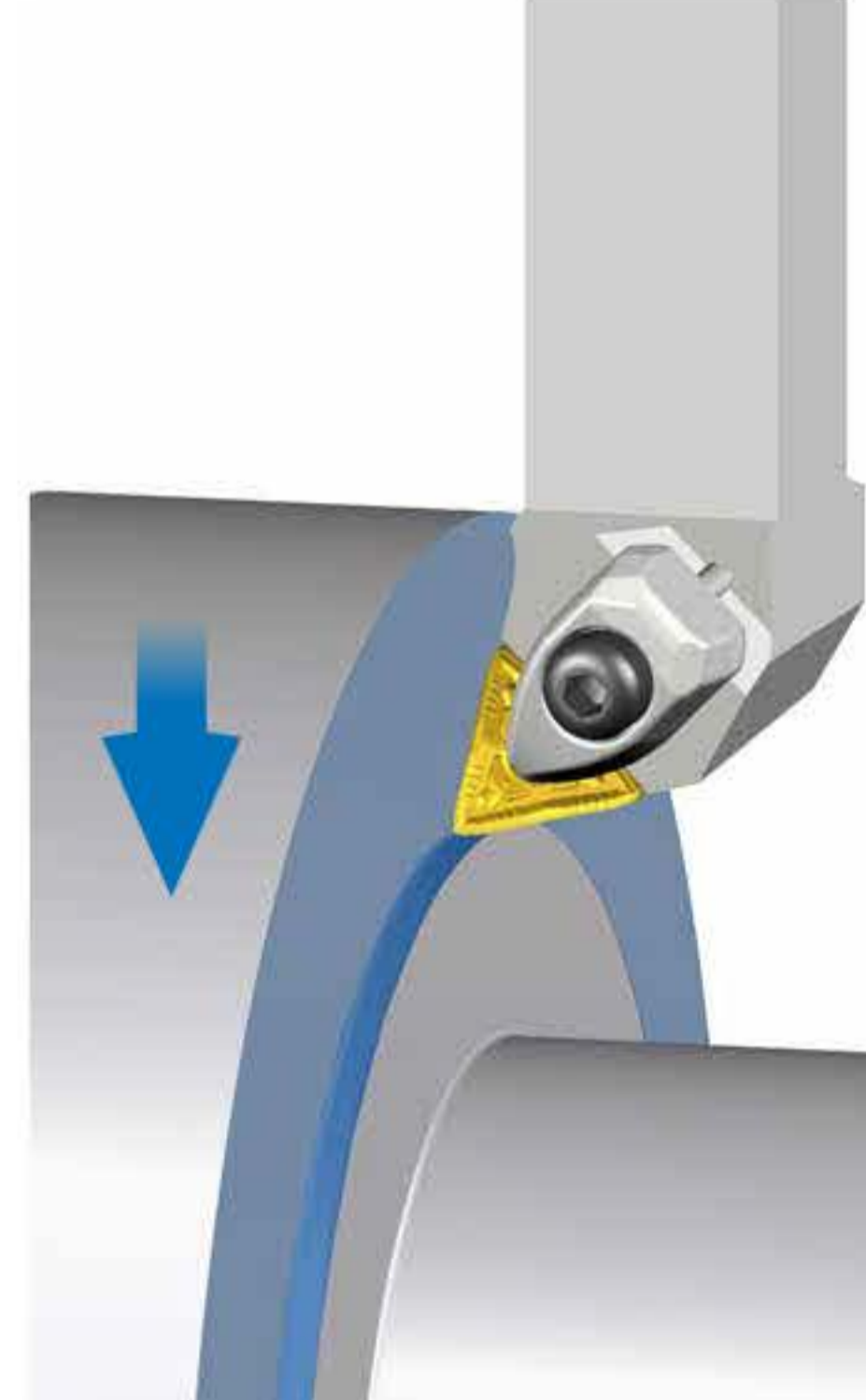
Application					
Chip breaker	Cutting condition	High feed backward turning (BWT)	High feed backward facing (BWF)	Deep depth of cut forward turning (FWT)	Deep depth of cut forward facing (FWF)
BM	feed (mm/rev)	1.0 (0.6-1.2)		0.3 (0.2-0.6)	
	ap(mm)	1.5 (0.7-2.0)		2.0 (0.5-3.5)	
BS	feed (mm/rev)	1.0 (0.6-1.2)		0.3 (0.2-0.4)	
	ap(mm)	1.5 (0.7-2.0)		2.0 (1.0-3.5)	
Entering angle (°)		15		95	
Ramping angle (°)		12		12	

- ▶ Capable of high feed turning in BWT and BWF
- ▶  Be aware that the insert may be damaged if the depth of cut is exceeded in high feed backward turning.

TNMV BM's **backward turning** chip control range

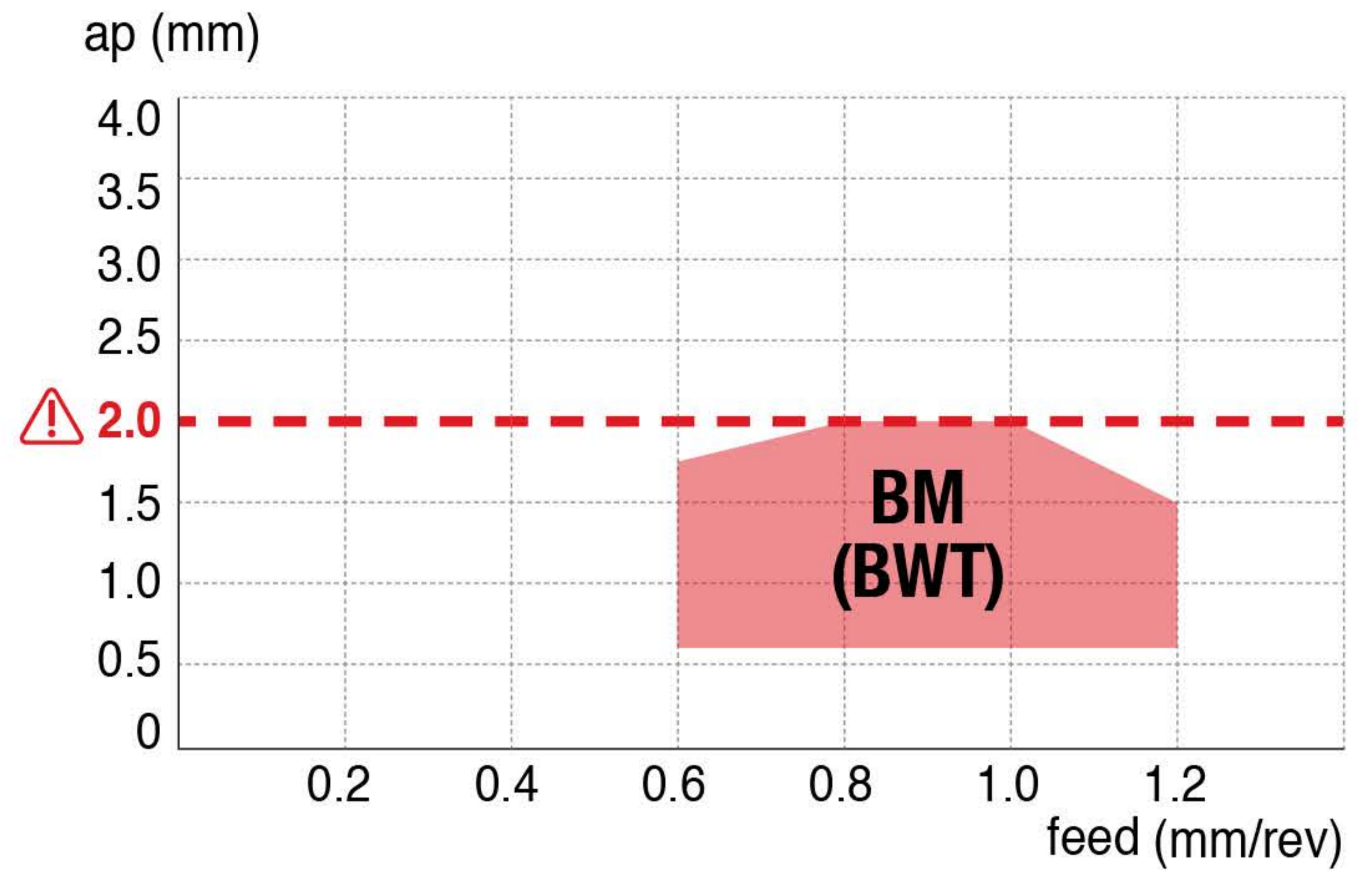
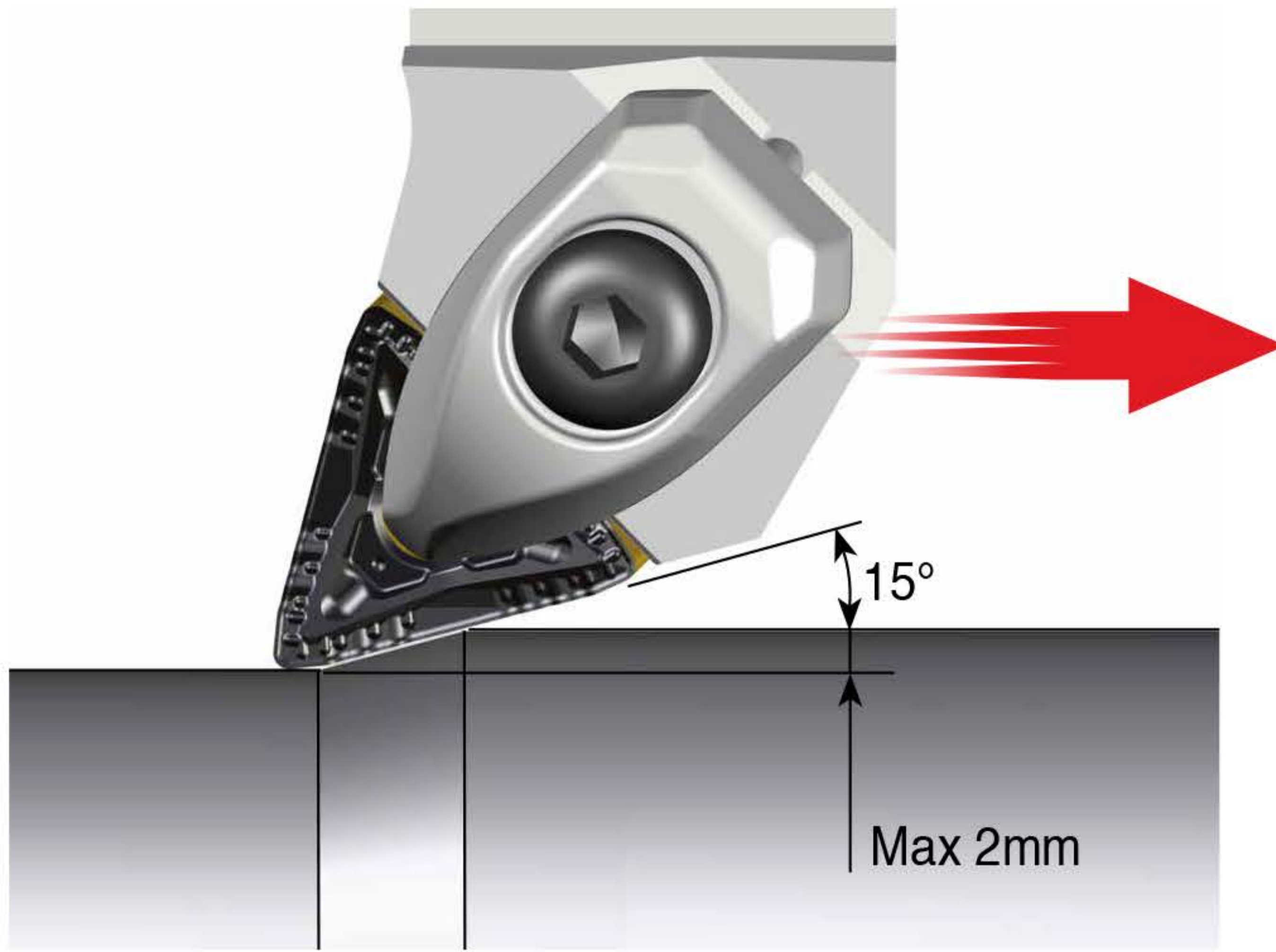

⚠ CAUTION
Be sure to check the limit of the depth of cut when backward machining. Inserts may break if the depth of cut is exceeded.

- ▶ Insert: TNMV 210908-BM
- ▶ Cutting speed(V): 200 m/min
- ▶ Workpiece: SCM 440 (HB230~260)

TNMV BM's **forward turning** chip control range

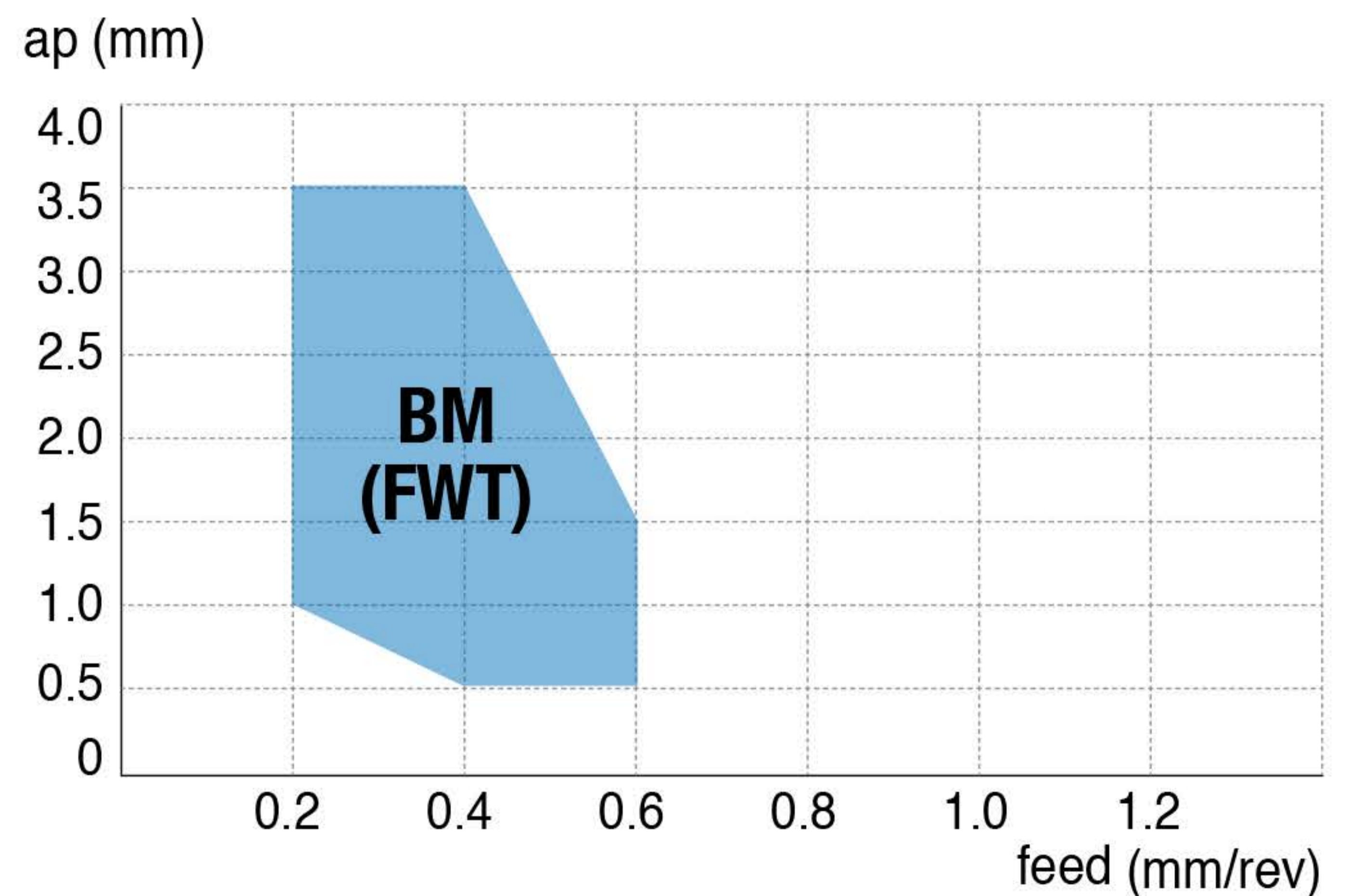
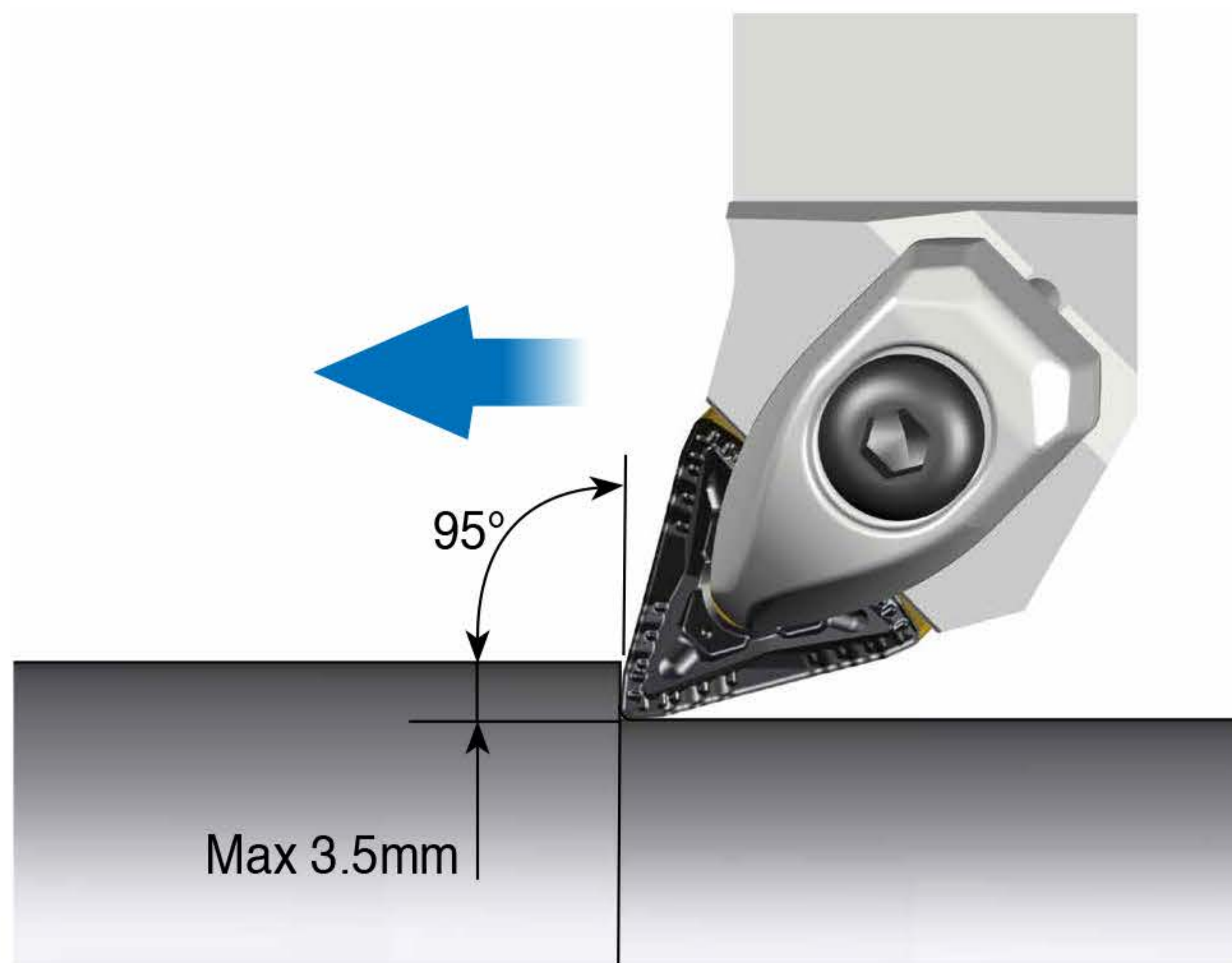

- ▶ Insert: TNMV 210908-BM
- ▶ Cutting speed(V): 200 m/min
- ▶ Workpiece: SCM 440 (HB230~260)

TNMV BS's **backward turning** chip control range

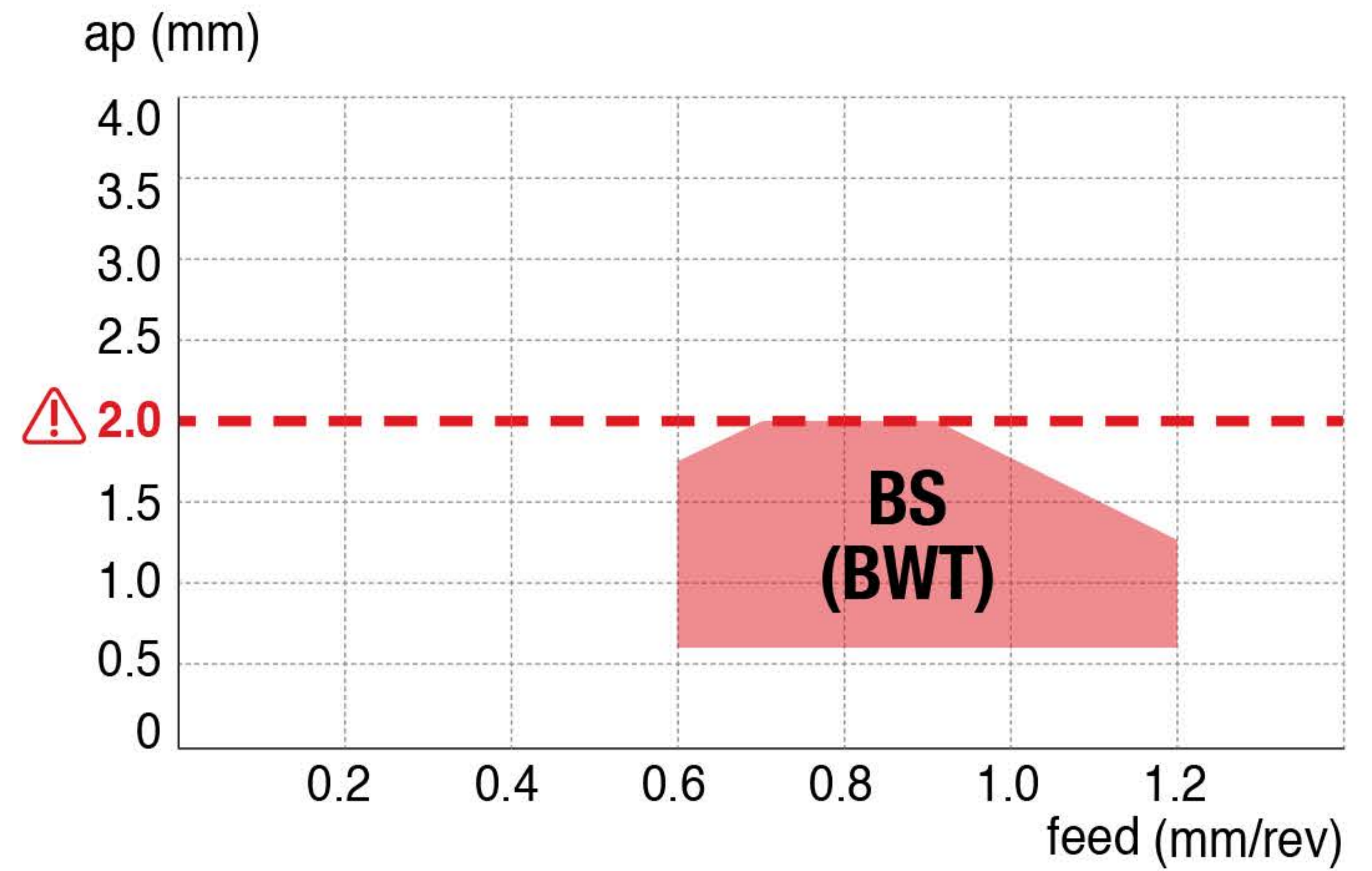
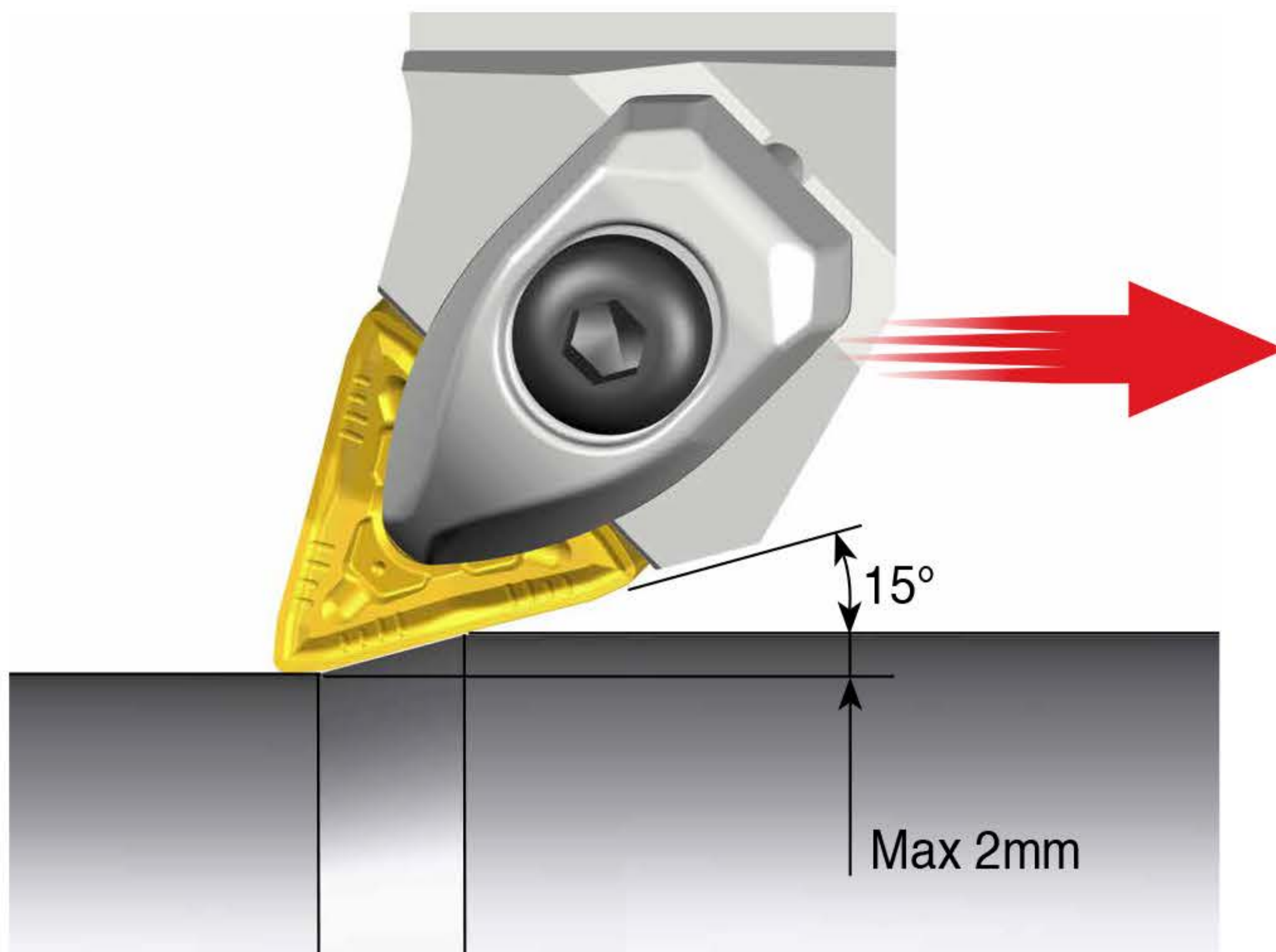

CAUTION
Be sure to check the limit of the depth of cut when backward machining. Inserts may break if the depth of cut is exceeded.

- ▶ Insert: TNMV 210908-BS
- ▶ Cutting speed(V): 200 m/min
- ▶ Workpiece: SUS 304 (HB140~160)

TNMV BS's **forward turning** chip control range

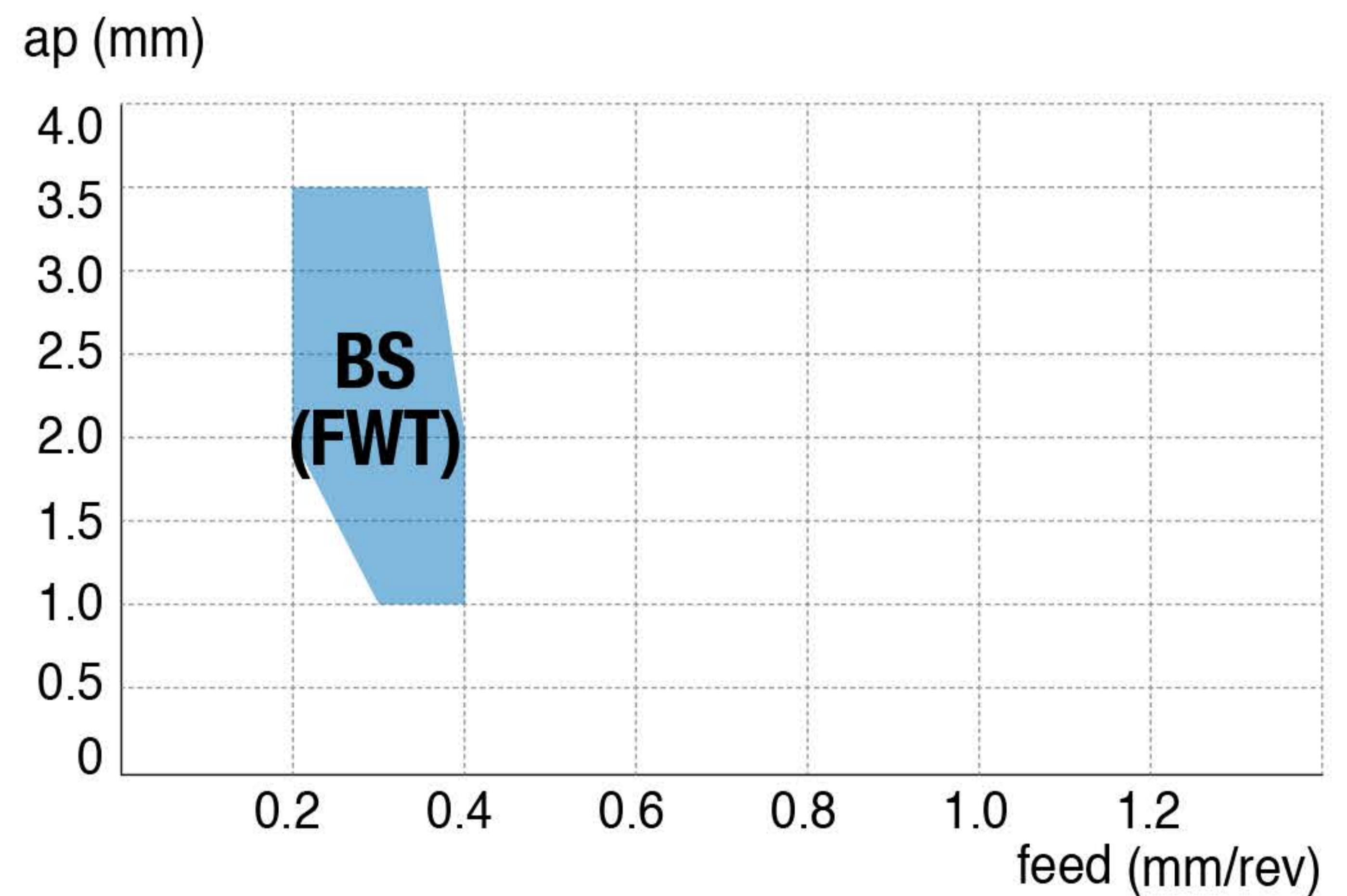
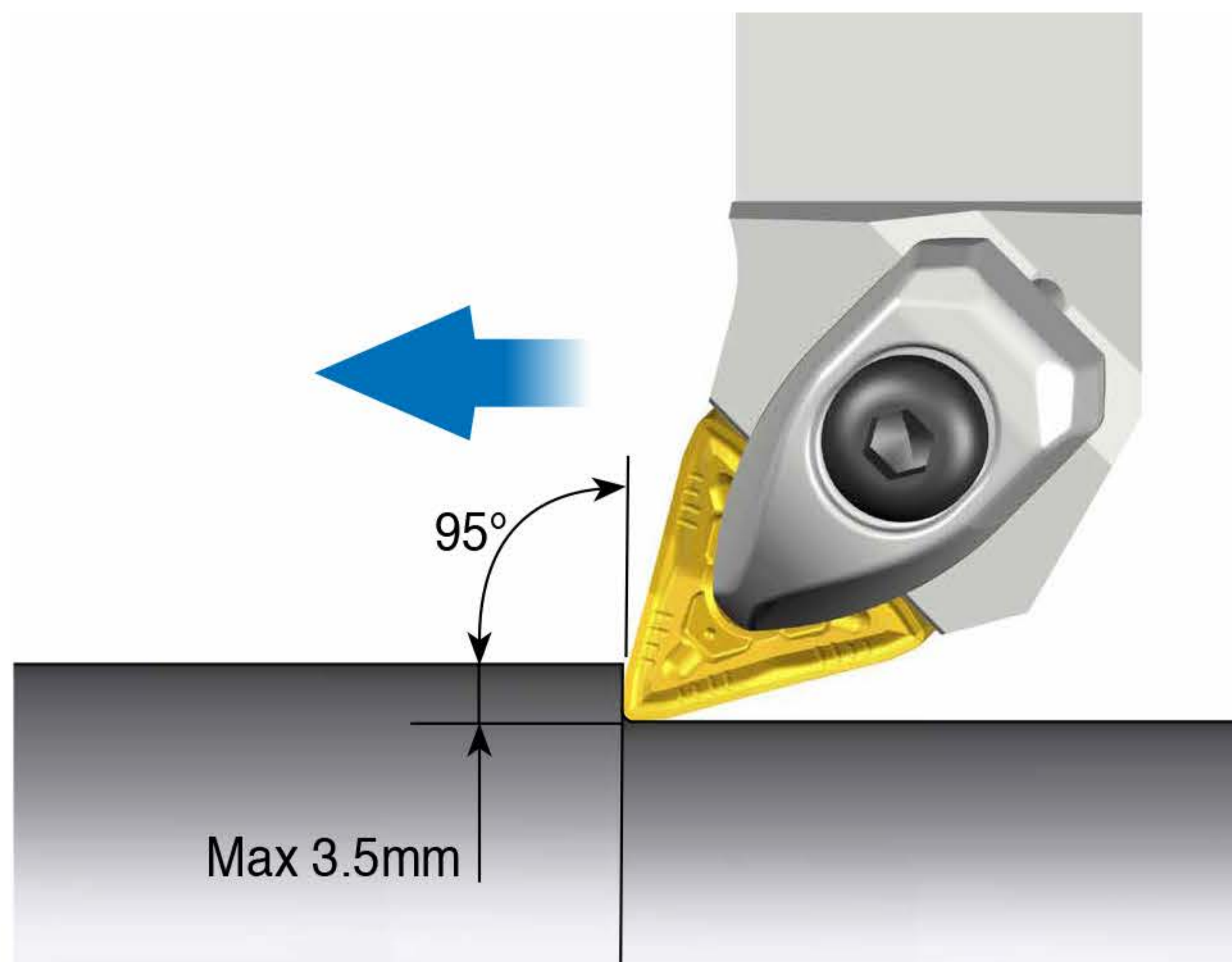

- ▶ Insert: TNMV 210908-BS
- ▶ Cutting speed(V): 200 m/min
- ▶ Workpiece: SUS 304 (HB140~160)

Radial entry recommendations

- For correct high feed backward turning, remember to enter the workpiece in a radial direction with a lower feed rate (0.2-0.35 mm/rev) to avoid decreasing the tool life and damaging the tool.



Radial entry tool path recommendations

- Circular interpolation tool path radius must be equal to the depth of cut with 0.3 mm/rev feed rate. Circular interpolation prevents rapid load changes, insert chipping and tool damage. Also, as the cutting depth is kept constant, chip control is also obtained.

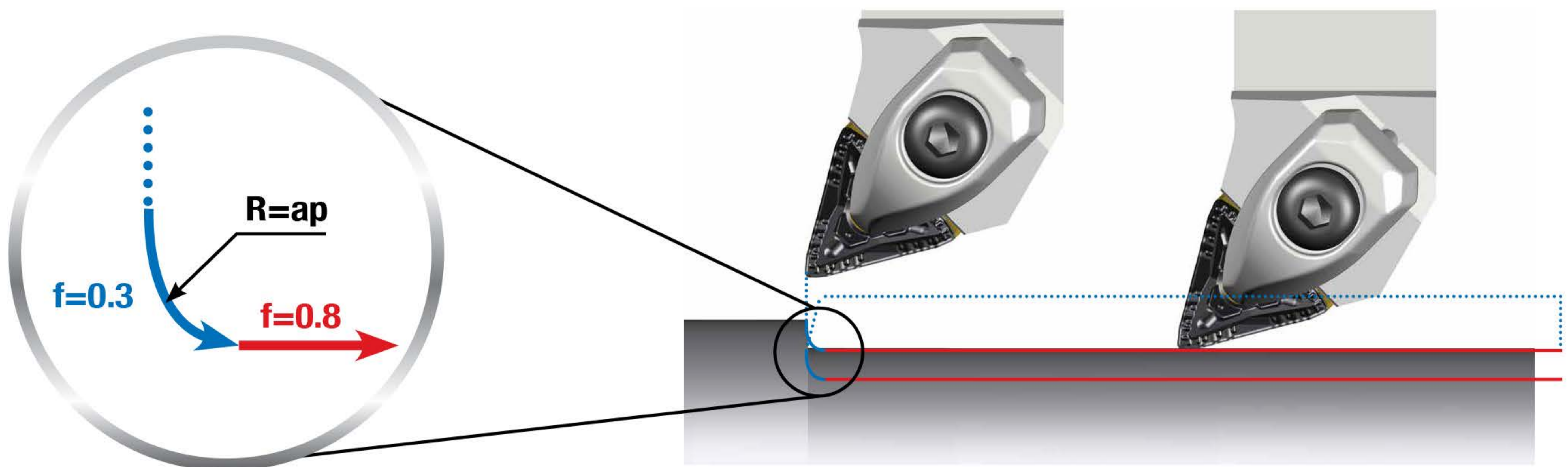

TTQNR/L TTQNR/L-TB

T-holders

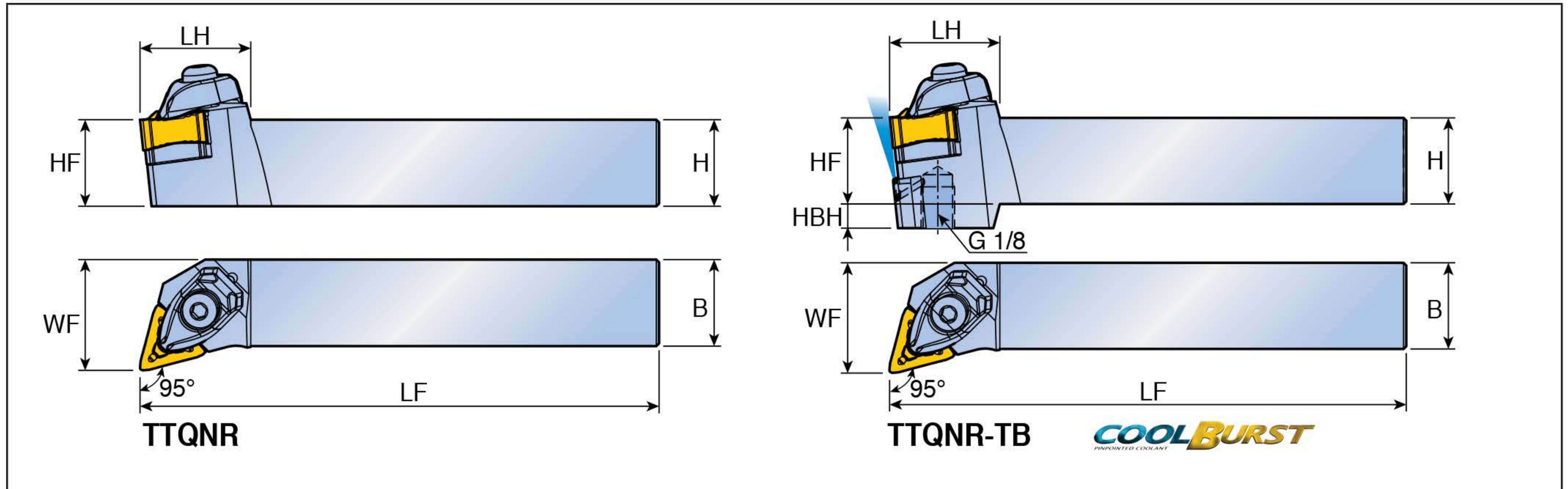

Approach angle	Designation	Dimension (mm)							Insert
		H	HF	B	LF	LH	WF	HBH	
TNMV 15°(BWT) 95°(FWT)	TTQNR/L 2525 M2109	25	25	25	150	32	32	-	TNMV 2109...
	TTQNR/L 3232 P2109	32	32	32	170	32	40	-	
	TTQNR/L 2525 M2109-TB	25	25	25	150	32	32	7	
	TTQNR/L 3232 P2109-TB	32	32	32	170	32	40	-	

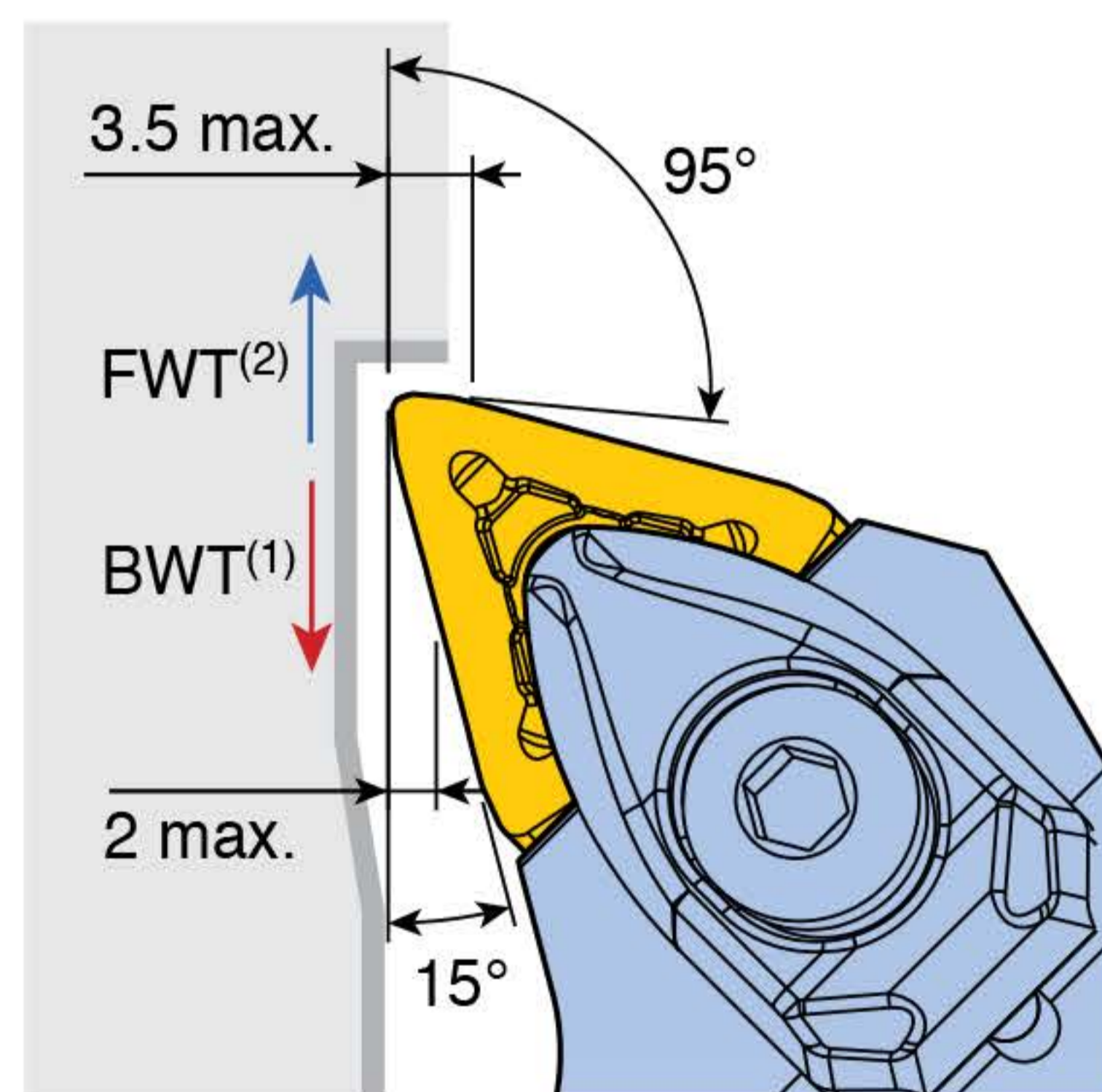
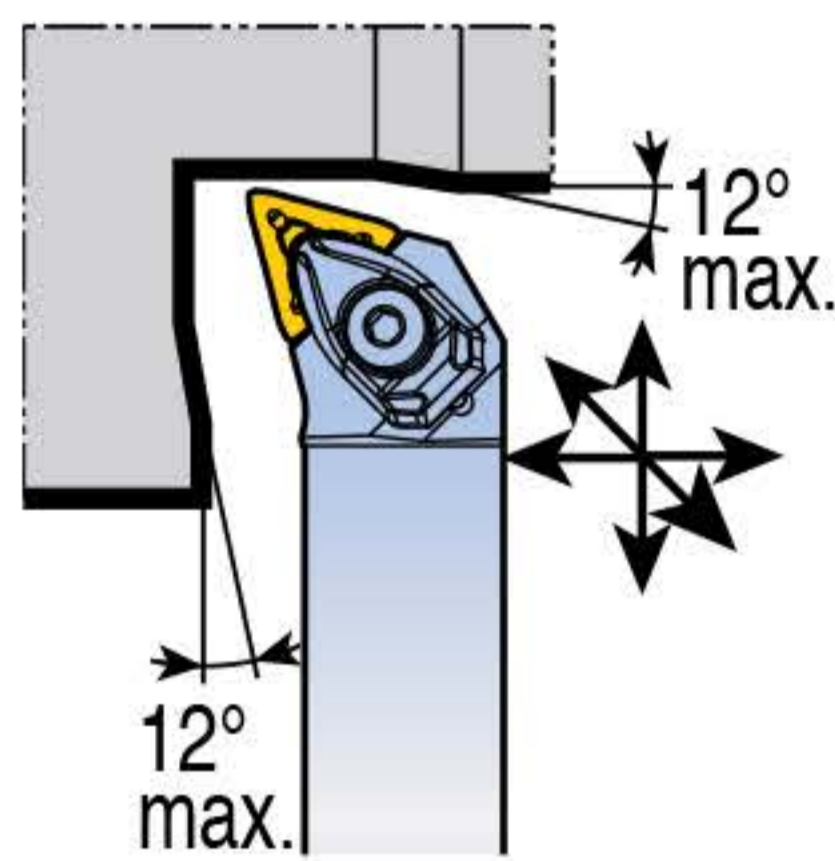

Facing

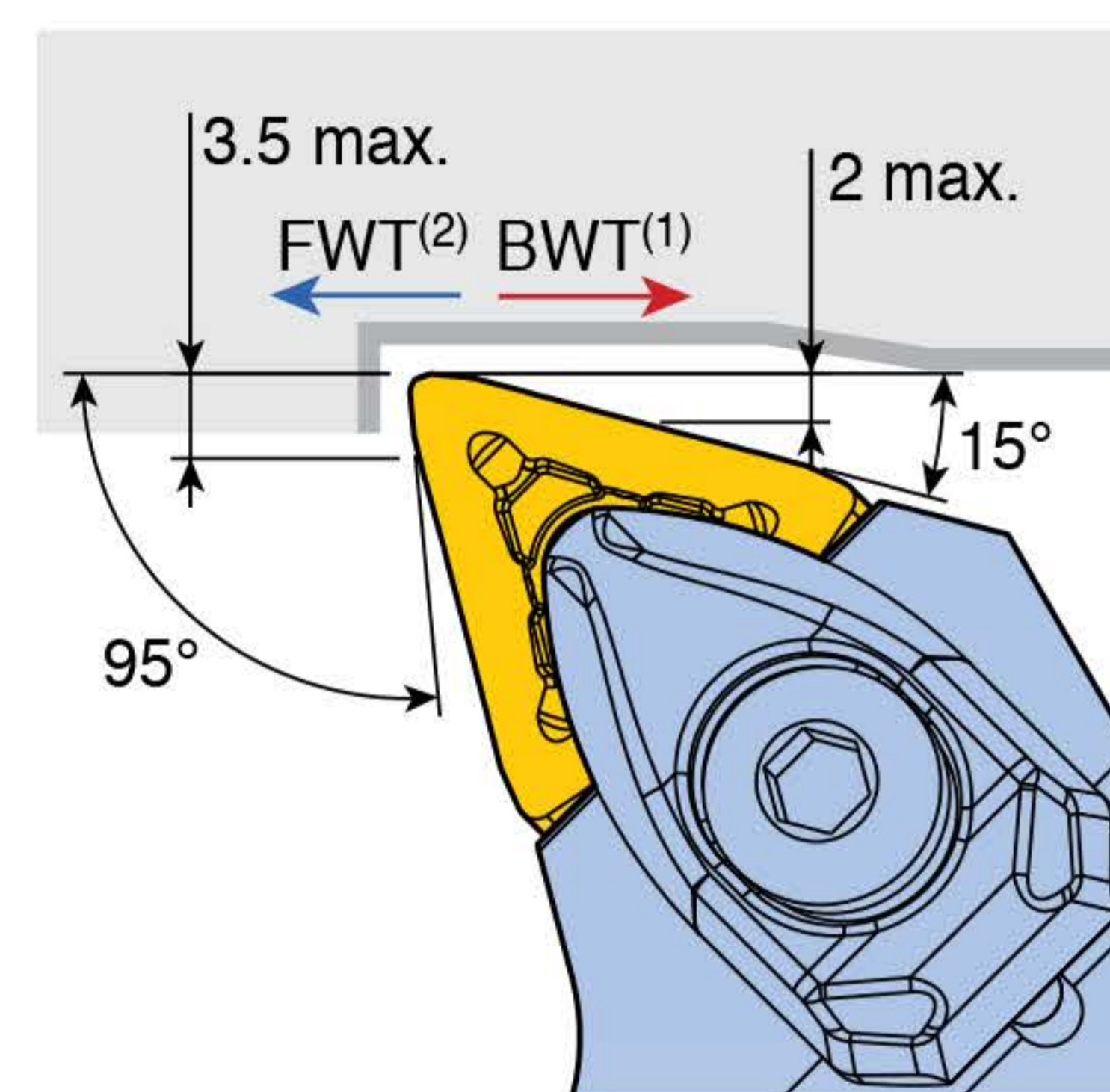

Ext. Turning

- ▶ (1) BWT: Backward turning
- ▶ (2) FWT: Forward turning

Spare parts

Designation	Clamp	Clamp screw	Spring	Shim	Shim screw	Wrench	
... 2109	DLM 4.4T-NV	DLS 5	DSP 5	TSTV 210510	TS 35083I/HG	L-W 4	T 10
... 2109-TB	DLM 4.4T-NV	DLS 5	DSP 5	TSTV 210510	TS 35083I/HG	L-W 4	T 10

TNMV

Negative triangular inserts

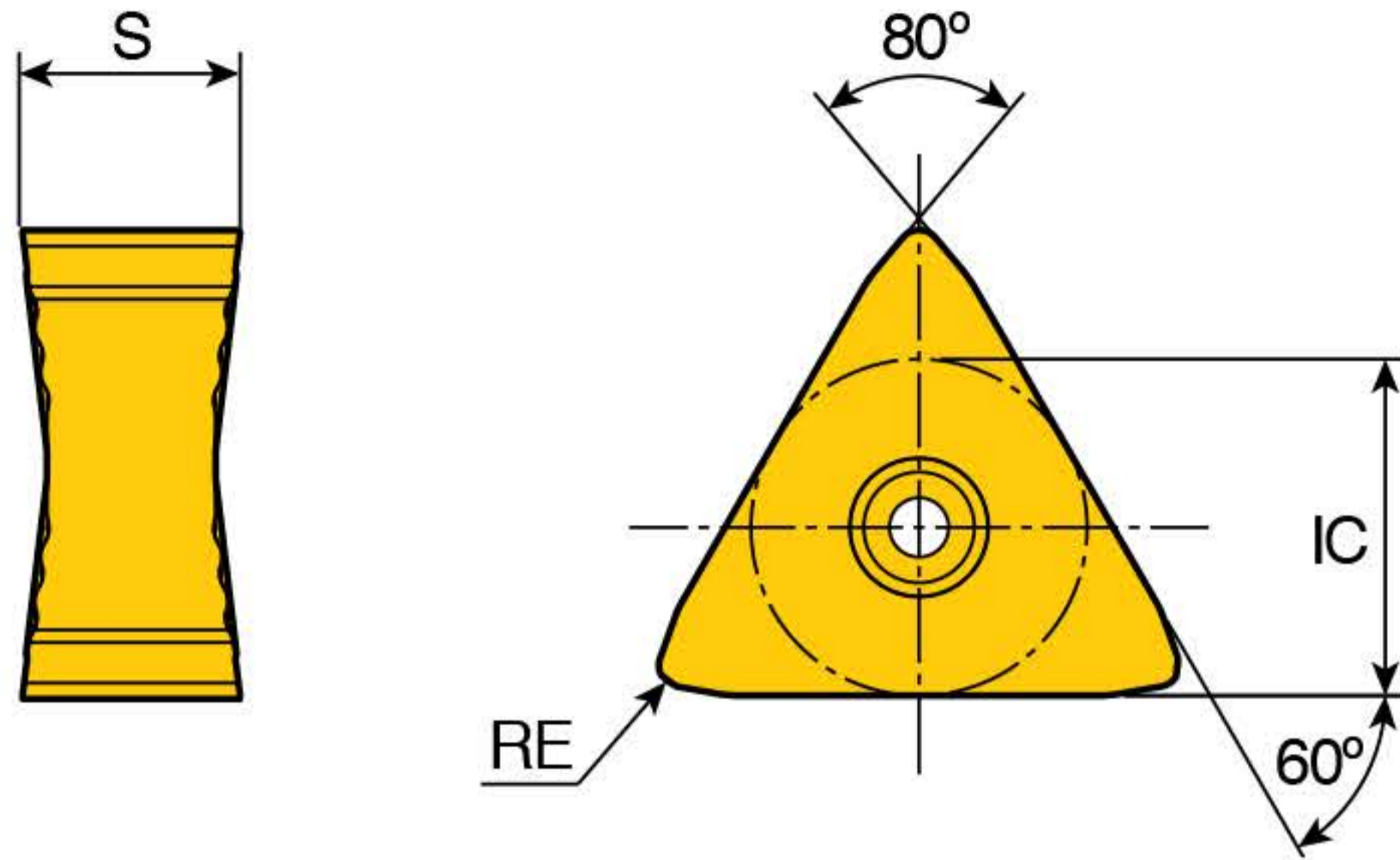

Size	Dimension (mm)		
	IC	S	RE
21	12.5	9	0.8

Insert	Designation	BWT ⁽¹⁾		FWT ⁽²⁾		CVD coated			PVD coated
		ap (mm)	Feed (mm/rev)	ap (mm)	Feed (mm/rev)	TT8115B	TT8125B	TT9225	TT9080
	TNMV 210908-BM	0.7-2.0	0.6-1.2	0.5-3.5	0.2-0.6	●	●		
	TNMV 210908-BS	0.7-2.0	0.6-1.2	1.0-3.5	0.2-0.4			●	●

- ▶ ⁽¹⁾ BWT: Backward turning
 - ▶ ⁽²⁾ FWT: Forward turning
 - ▶ Be aware that the insert may be damaged if the depth of cut is exceeded in high feed backward turning.
- : Standard items

CONTACT US



MEGA TECH METALWORK CO.,LTD (Headquarter)



Tel : 02-943-1591



Fax : 02-943-1592



Line ID : @mgt_metalwork



Email : sales.m@mgtg.co.th



Web : <https://www.mgtg.co.th/>



**17/4 Soi Ramintra 89
Ramintra Khannayao
Bangkok 10230**

