

# NEW PRODUCT NEWS



Taegutec Milling Line

## MAXIRUSH

INTRODUCING INSERT TYPE MODULAR HEADS  
FOR MAXI-RUSH SHANKS



CHASEMILL



TANGSPEED  
TANGENTIAL MILL



NANRUSH  
HIGH FEED MILL



### KEY POINT

**TaeguTec has introduced insert type modular heads for the MAXI-RUSH line of shanks.**

The insert type modular heads of the TANG-SFEED, CHASE-MILL and NAN-RUSH products have been incorporated into the flexible MAXI-RUSH line in order to further diversify the popular line's application range. Due to their easy indexable head replacement of the shank mounted to the chuck, the additions to the line offer superior performance, improved productivity and reduced set-up time. For more information, please contact the product manager.

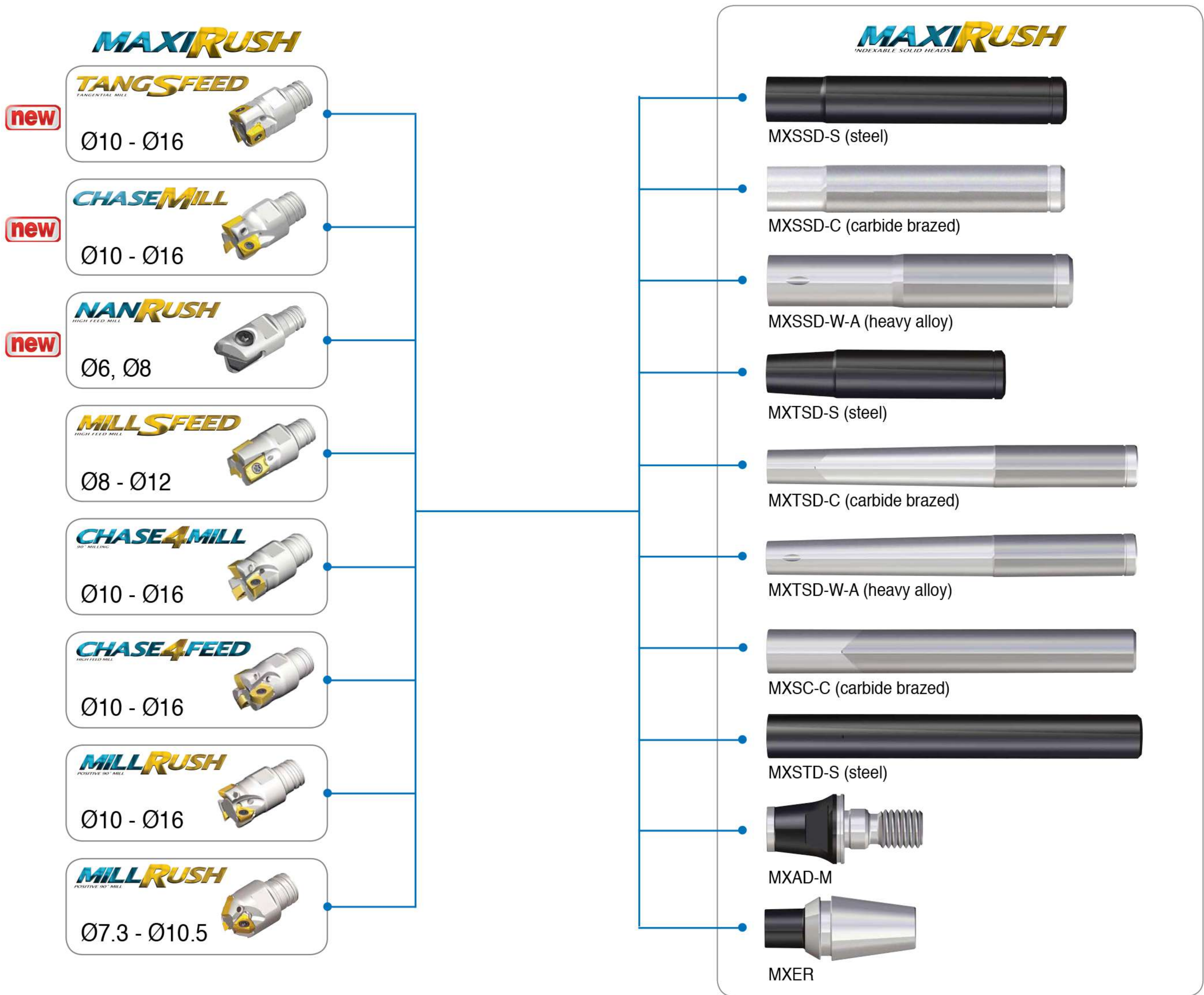



### 4T-TE90-S-05

### TANGSPEED MAXIRUSH

TANGENTIAL MILL

#### Modular heads

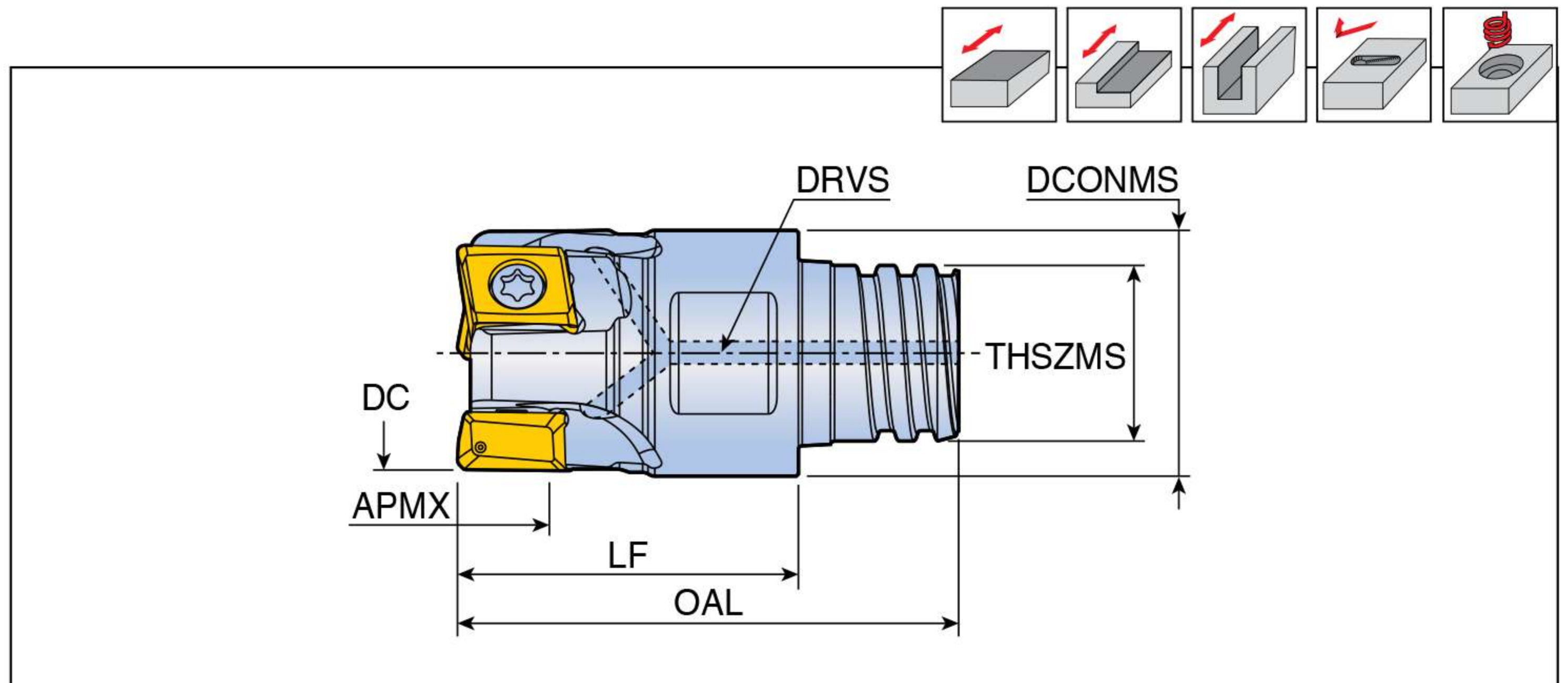
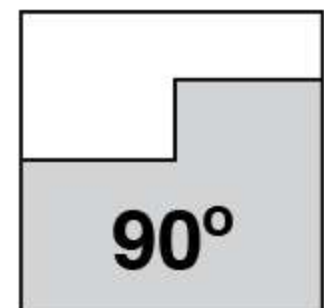

Designation	Z	Dimension (mm)							Coolant hole	Insert
		DC	DCONMS	LF	OAL	THSZMS	APMX	DRVS		
<b>4T-TE90- 210-S06-05</b>	2	10	9.6	15	21.3	S06	4.6	8	●	LPK(H)U 05
<b>312-S08-05</b>	3	12	11.5	16	23.5	S08	4.6	10	●	
<b>416-S10-05</b>	4	16	15.2	20	31.3	S10	4.6	13	●	

• Matched with MAXI-RUSH holder

#### Spare parts

Designation	Screw	Wrench			
	<b>4T-TE90-05</b>	TS 180411/SG-P	TD 6P		



### TE90AX-S-06

### CHASEMILL MAXIRUSH

#### Modular heads

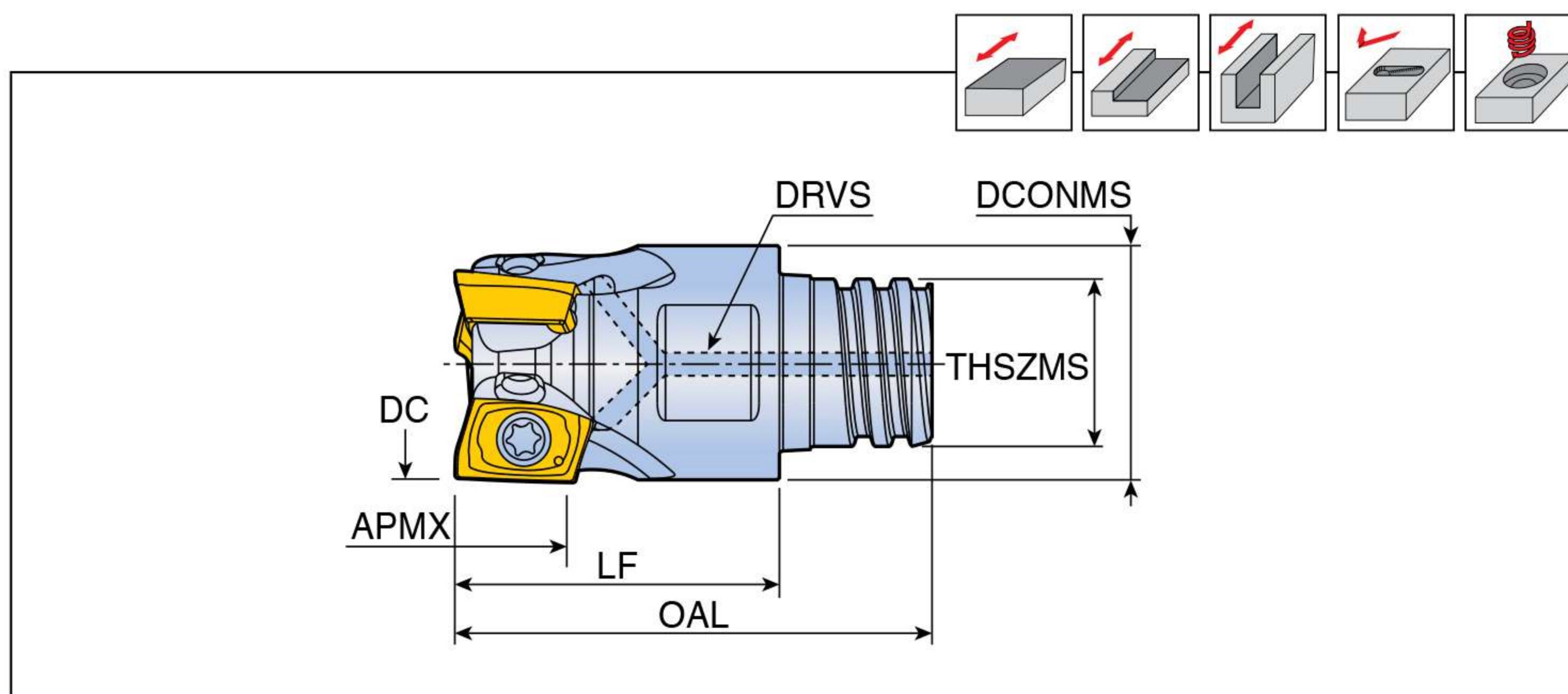
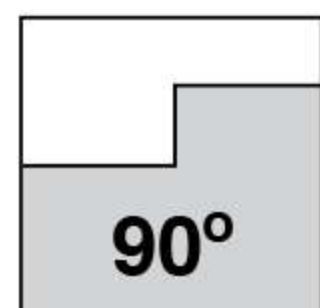

Designation	✳	Dimension (mm)							Coolant hole	Insert
		DC	DCONMS	LF	OAL	THSZMS	APMX	DRVS		
<b>TE90AX 210-S06-06</b>	2	10	9.6	15	21.3	S06	5.5	8	●	AXM(C)T 06
<b>312-S08-06</b>	3	12	11.5	16	23.5	S08	5.5	10	●	
<b>416-S10-06</b>	4	16	15.2	20	31.3	S10	5.5	13	●	

- Cutter body for 'AXMT 06' insert with corner radius more than 1.0mm should be modified accordingly  
body "RE"=Insert "RE"-0.1mm
- Matched with MAXI-RUSH holder

#### Spare parts

Designation	Screw	Wrench			
	<b>TE90AX-06</b>	TS 18041/HG	TD 6P		



### THFN-S

**NANRUSH MAXIRUSH**  
HIGH FEED MILL

High feed modular heads

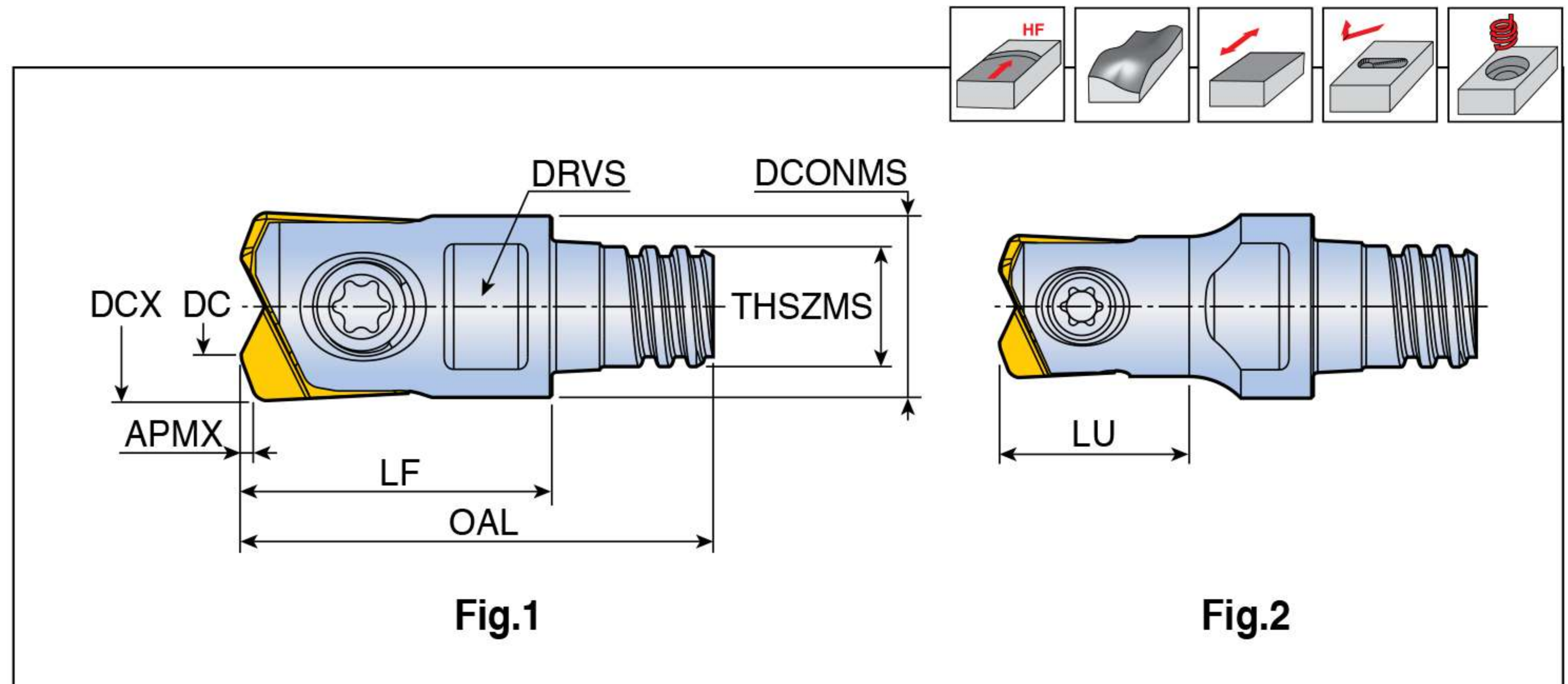

Designation	⊙	Dimension (mm)									Coolant hole	Fig.	Insert
		DCX	DC	DCONMS	LF	LU	OAL	THSZMS	APMX	DRVS			
<b>THFN 060-S05</b>	2	6	3	7.6	13	7.8	19.7	S05	0.3	5.5	X	2	HFN 060
<b>THFN 080-S05</b>	2	8	4	7.6	13	-	19.7	S05	0.5	5.5	X	1	HFN 080

• Matched with MAXI-RUSH holder

### Spare parts

Designation	Screw	Wrench		Wrench handle	
<b>THFN 060</b>	TS 20F060A	TD 6	-	-	
<b>THFN 080</b>	TS 25F080A	-	TBLD T08-W4	THND 4W	



# CONTACT US



## MEGA TECH METALWORK CO.,LTD ( Headquarter )



**Tel : 02-943-1591**



**Fax : 02-943-1592**



**Line ID : @mgt\_metalwork**



**Email : sales.m@mgtg.co.th**



**Web : <https://www.mgtg.co.th/>**



**17/4 Soi Ramintra 89  
Ramintra Khannayao  
Bangkok 10230**

