

NEW PRODUCT NEWS

MEGA
TECH
METAL WORK CO.,LTD

Taegutec Milling Line

CHASE VQUAD

90° FACING & SHOULDERING

HEAD CHANGEABLE EXTENDED FLUTE CUTTER



KEY POINT

TaeguTec's CHASE-V-QUAD line now has a modular type extended flute option.

The CHASE-V-QUAD line, known for outstanding performance in the general machining market as well as heat-resistant and titanium alloys, now includes a modular type extended flute cutter. If the bottom pocket is damaged, the modular cutter can replace the head and continue operating for an overall better cost reduction.

※**Note: Only side cutting is possible without the head.**

Mounting system

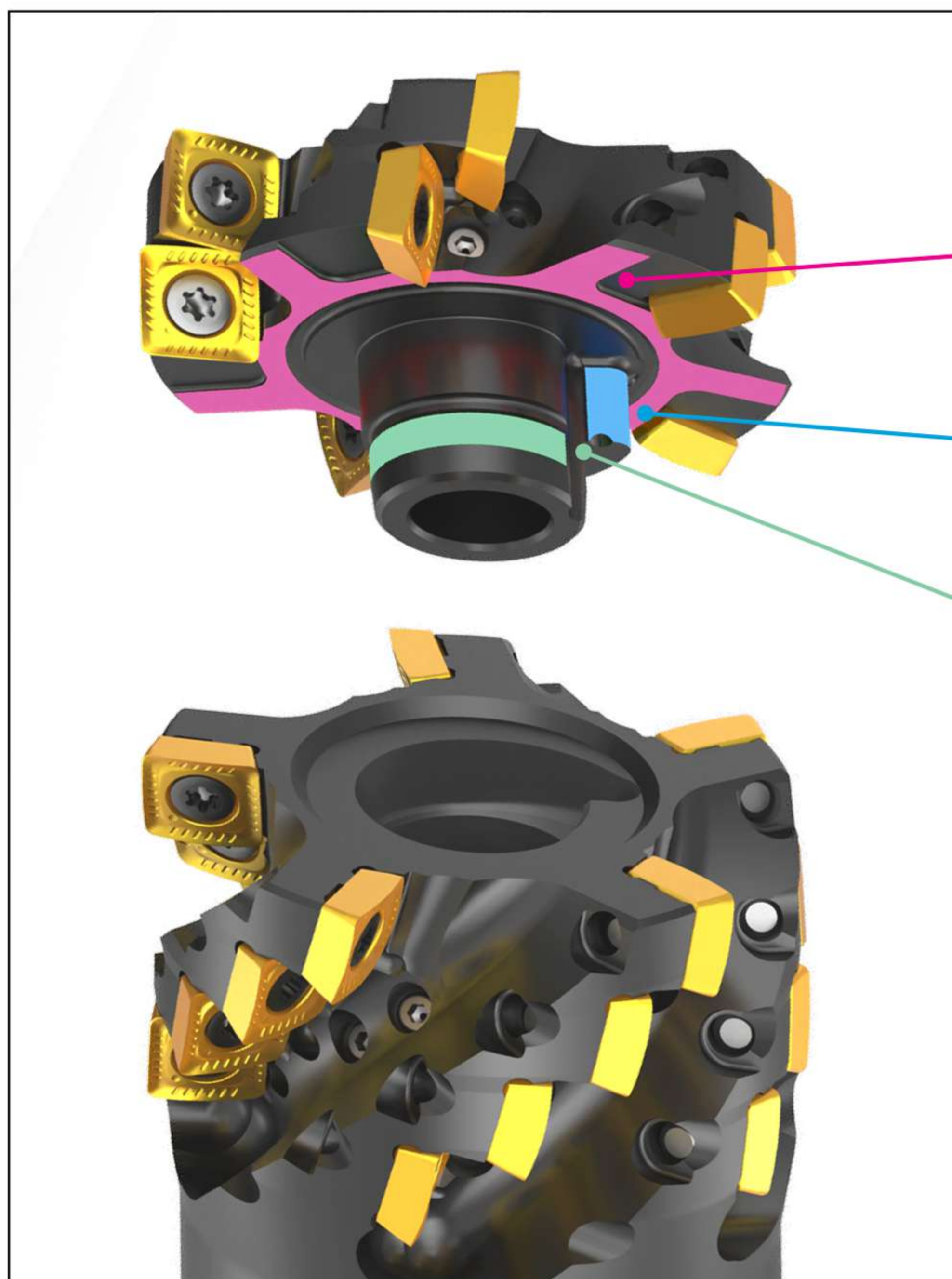

Wide flat contact face for precise axial runout

Unique keyway design enables strong power transfer during operation

Cylindrical contact face for precise radial runout

Taegutec Milling Line

Head Assembly

One screw design for easy and quick fastening

- End mill type: Assemble the head to the end mill body



- Shell mill type: Assemble the head and the cutter body to the arbor

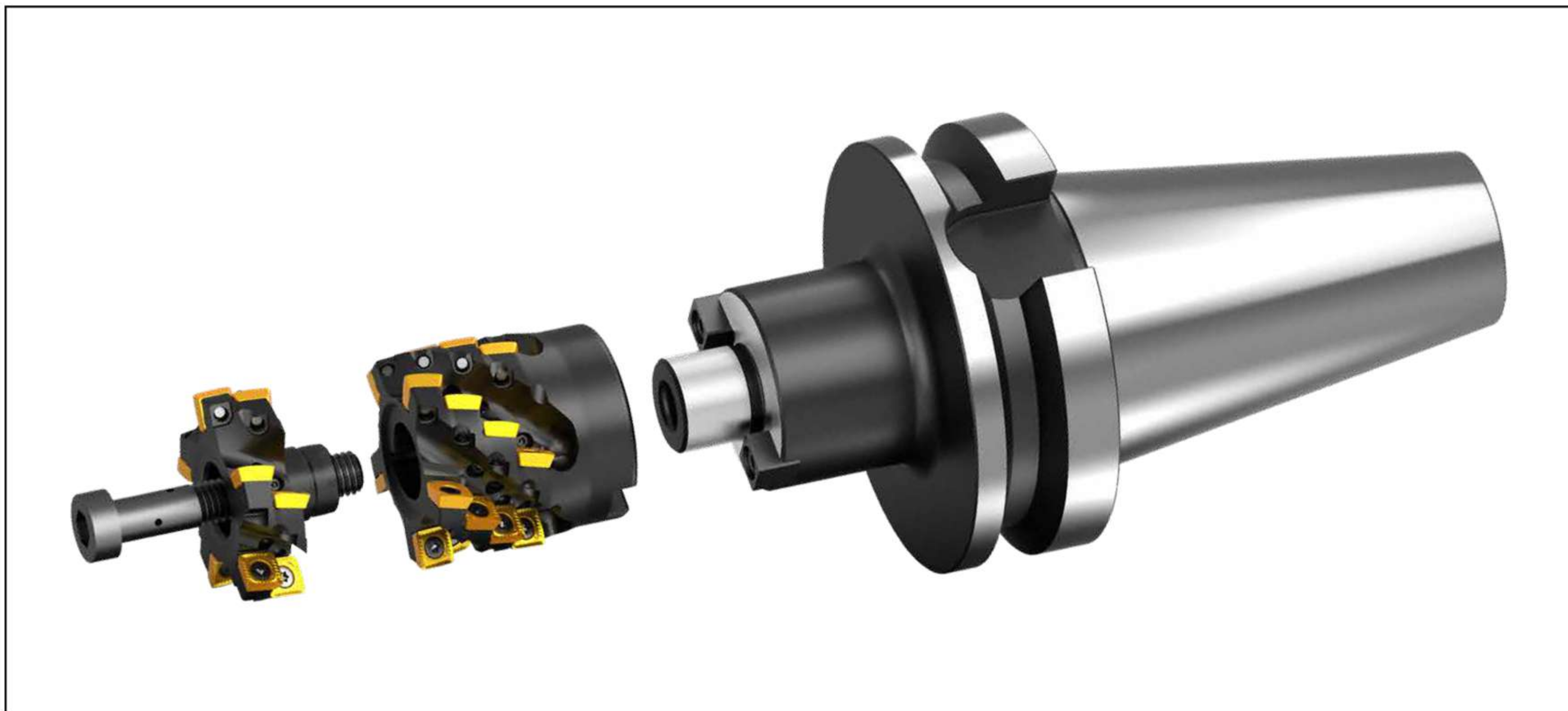

4S-TFP-09V/11V



Front heads for extended flute cutter

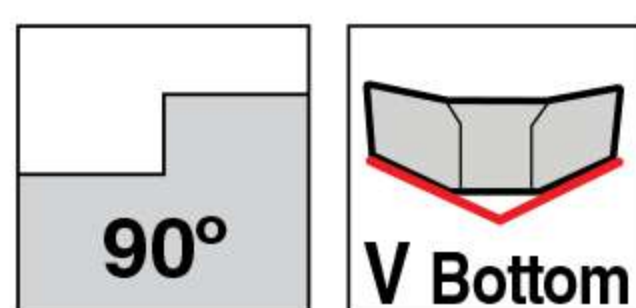
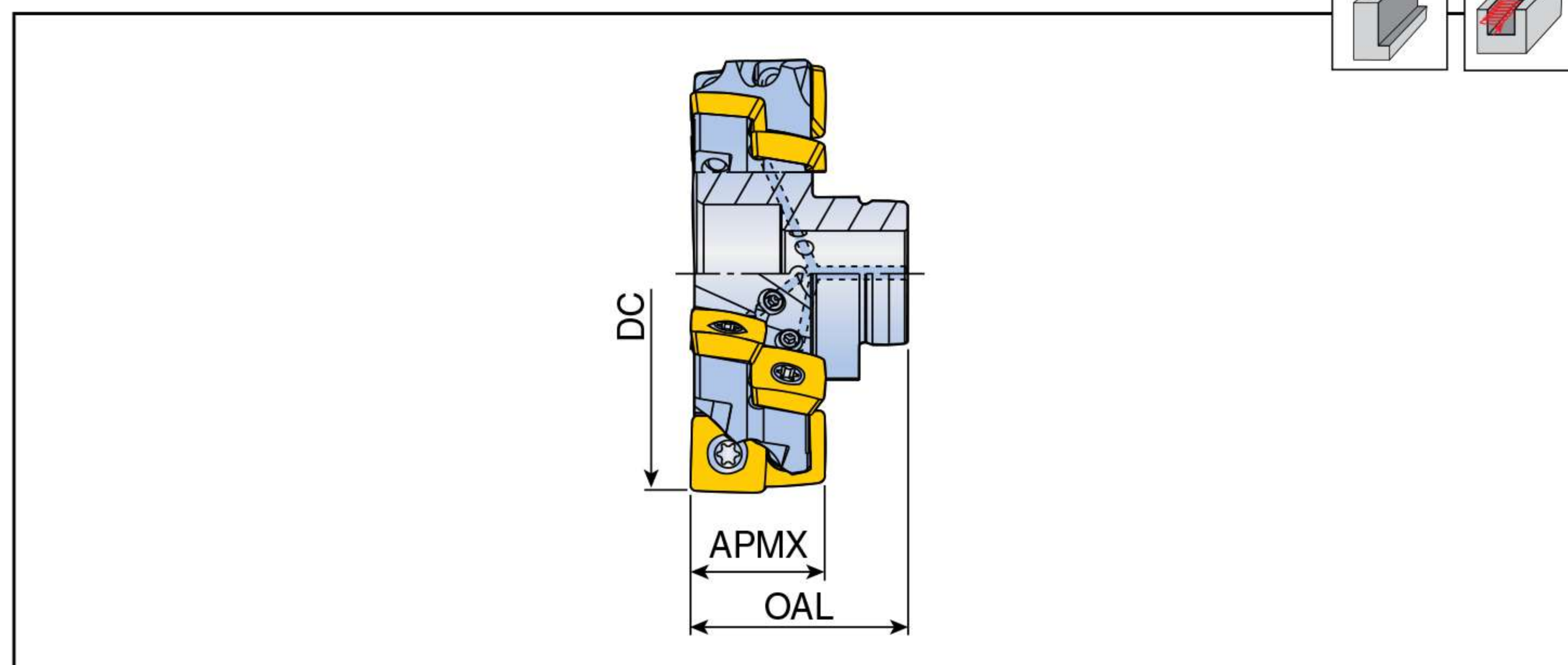

Designation		No. of insert	Dimension (mm)			Coolant hole	Kg	Insert
			DC	OAL	APMX			
4S-TFP- D40-14-09V-3F	3	6	40	27.8	14.7	●	0.1	SVKT 0938...
D50-14-09V-5F	5	10	50	27.8	14.7	●	0.1	
D63-14-09V-6F	6	12	63	27.8	14.7	●	0.2	
4S-TFP- D50-18-11V-4F	4	8	50	31.3	18.5	●	0.2	SVK(H)T 1145...
D63-18-11V-5F	5	10	63	31.3	18.5	●	0.3	
D80-18-11V-6F	6	12	80	31.3	18.5	●	0.5	

► Base unit ordered seperately

Spare parts

Designation	Screw	Wrench	Wrench handle	Coolant Nozzle	
4S-TFP-09V	TS 35A070I/HG	TBLD T10P-W6	SW6-T	SS 3003-06C	
4S-TFP-11V	TS 40093I/HG	TBLD T15-W6	SW6-T	SS 3003-06C	

4S-TEF-B-09V



Base units for extended flute cutter

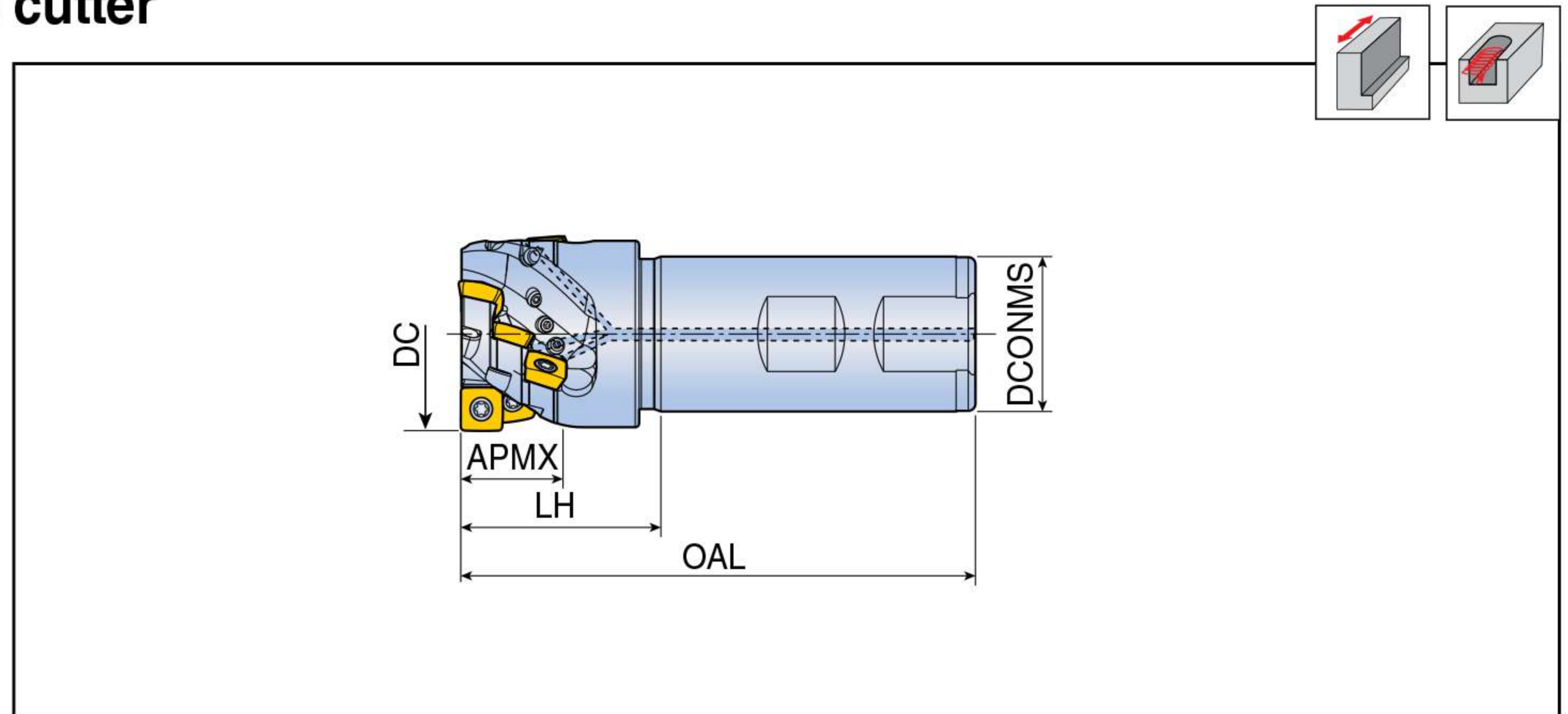
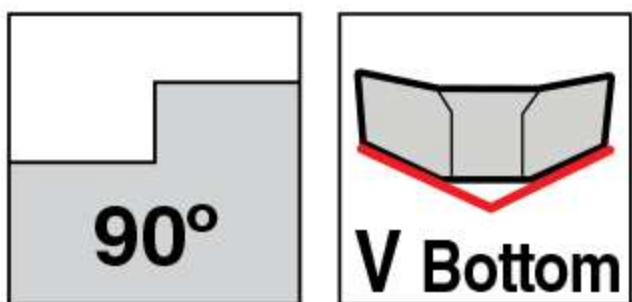

Designation	No. of insert	Dimension (mm)					Coolant hole	Kg	Mounting bolt	Insert	
		DC	DCONMS	OAL	LH	APMX					
4S-TEF-D40B-21-W32-09V-3F	3	9	40	32	106.4	41.4	21	●	0.6	SH M8X45-C	SVKT 0938...

► Front head ordered separately ► Note: For bottom facing, both the front head and base unit must be connected.

Spare parts

Designation	Screw	Wrench	Wrench handle	Coolant Nozzle
4S-TEF-09V	TS 35A070I/HG	TBLD T10P-W6	SW6-T	SS 3003-06C

Assembly

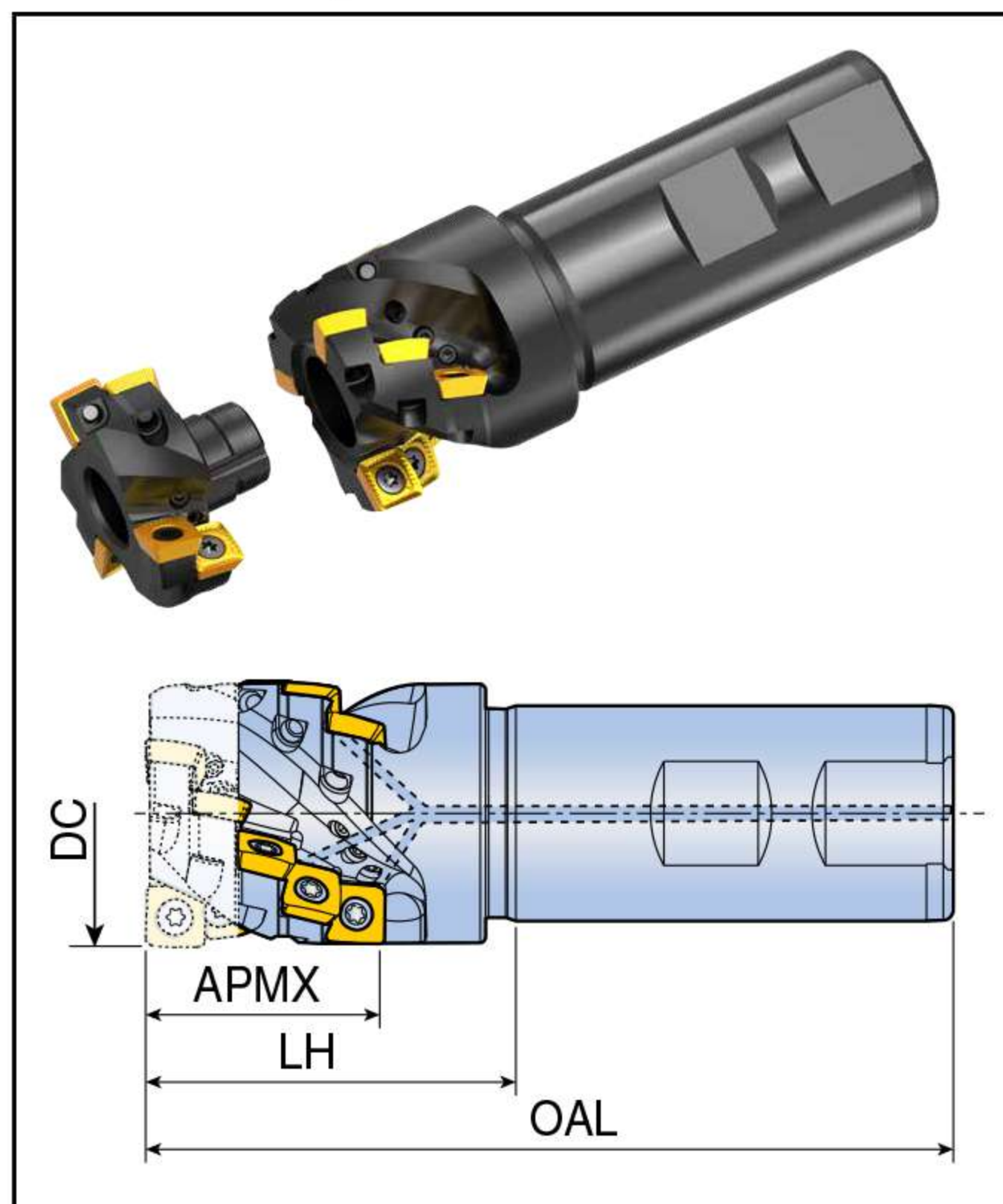

Designation	No. of insert	Dimension (mm)				
		DC	OAL	LH	APMX	
Head 4S-TFP-D40-14-09V-3F	3	15	40	120	55	34
Base 4S-TEF-D40B-21-W32-09V-3F						

4S-TES-B-09V/11V



Base units for extended flute cutter

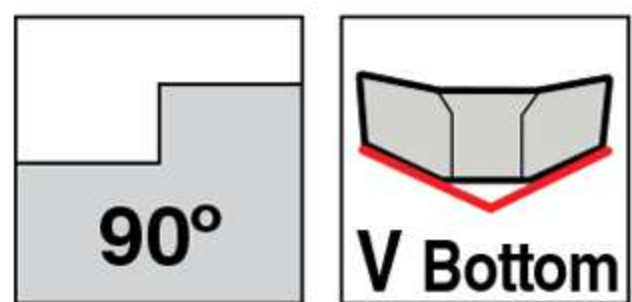
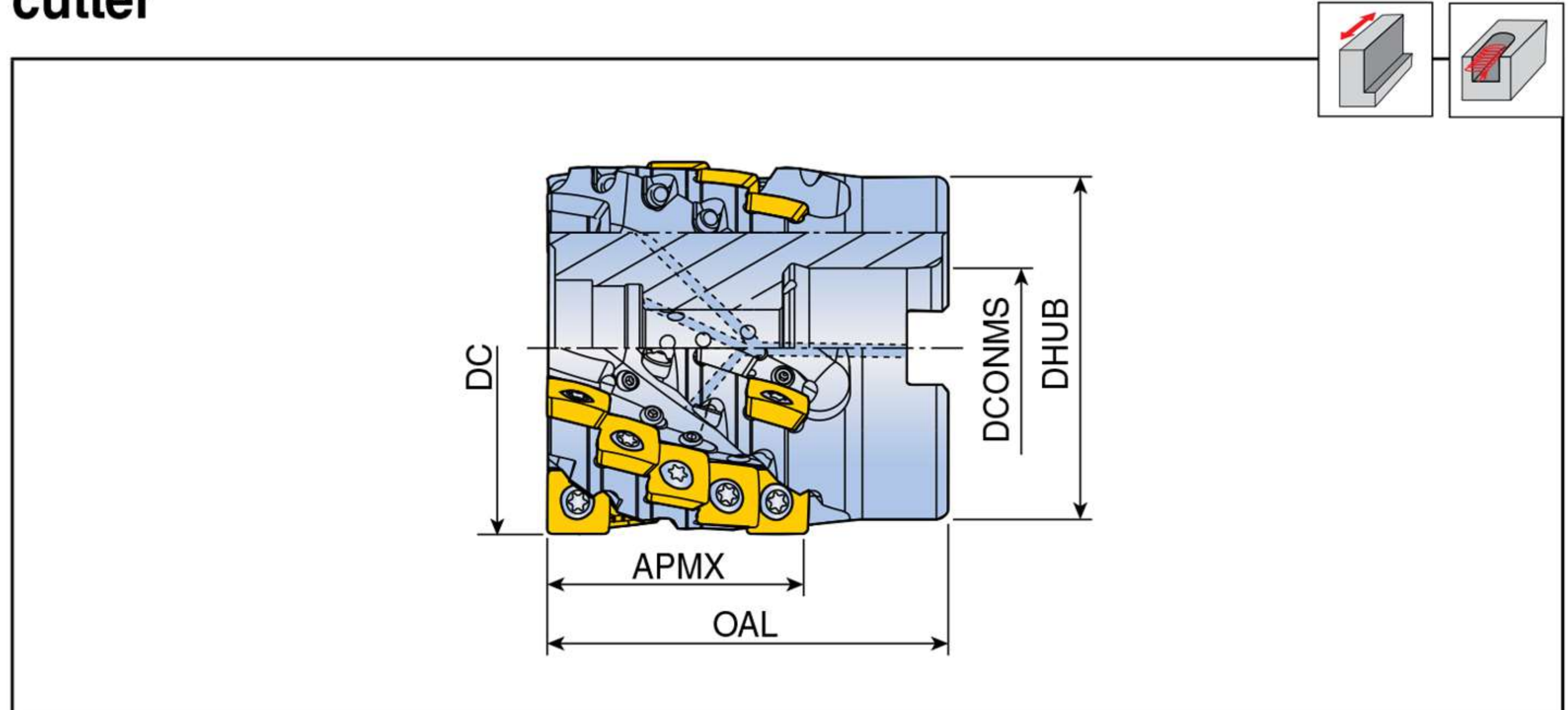

Designation	No. of insert	Dimension (mm)					Coolant hole	Arbor style	Kg	Mounting bolt	Insert	
		DC	DCONMS	DHUB	OAL	APMX						
4S-TES-D40B-21-16R-09V-3F	3	9	40	16	38	41.4	20	●	A	0.2	SH M8X45-C	SVKT
D50B-27-22R-09V-5F	5	20	50	22	45	49.4	27	●	A	0.4	LH M10X60-C	0938...
D63B-34-27R-09V-6F	6	30	63	27	58	56.4	34	●	A	0.7	LH M12X70-C	
4S-TES-D50B-34-22R-11V-4F	4	16	50	22	45	57.8	34	●	A	0.5	SH M10X60-C	SVK(H)T
D63B-43-27R-11V-5F	5	25	63	27	58	67.8	43	●	A	1.0	SH M12X70-C	1145...
D80B-59-32R-11V-6F	6	42	80	32	76	82.8	59	●	A	2.0	LH M16X80-C	

► Front head ordered separately ► Note: For bottom facing, both the front head and base unit must be connected.

Spare parts

Designation	Screw	Wrench	Wrench handle	Coolant Nozzle
4S-TES-B-09V	TS 35A070I/HG	TBLD T10P-W6	SW6-T	SS 3003-06C
4S-TES-B-11V	TS 40093I/HG	TBLD T15-W6	SW6-T	SS 3003-06C

Assembly

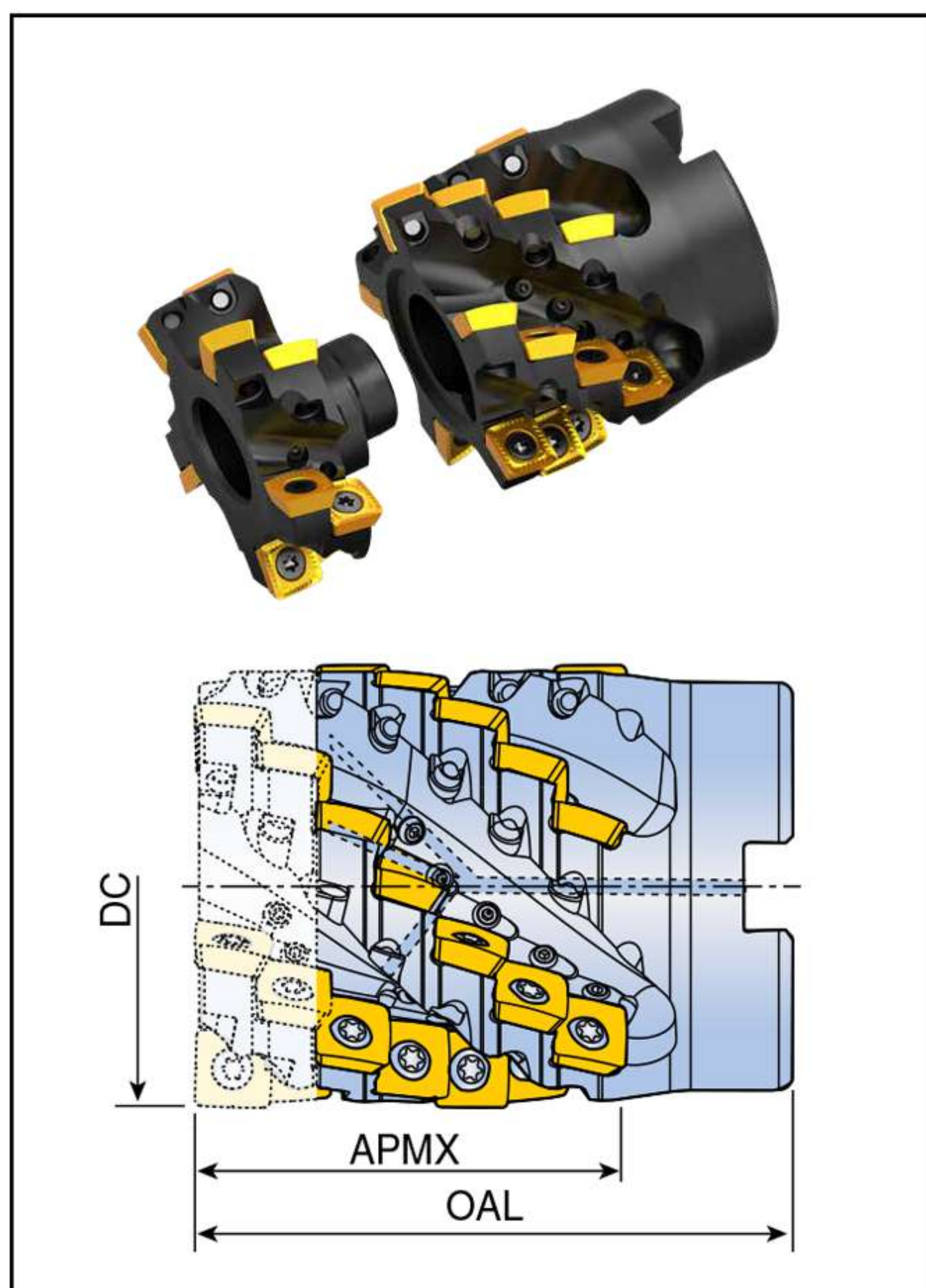

Designation	No. of insert	Dimension (mm)			
		DC	OAL	APMX	
Head 4S-TFP-D40-14-09V-3F	3	15	40	55	34
Base 4S-TES-D40B-20-16R-09V-3F					
Head 4S-TFP-D50-14-09V-5F	5	30	50	63	41
Base 4S-TES-D50B-27-22R-09V-5F					
Head 4S-TFP-D63-14-09V-6F	6	42	63	70	48
Base 4S-TES-D63B-34-27R-09V-6F					
Head 4S-TFP-D50-18-11V-4F	4	24	50	75	52
Base 4S-TES-D50B-34-22R-11V-4F					
Head 4S-TFP-D63-18-11V-5F	5	35	63	85	60
Base 4S-TES-D63B-43-27R-11V-5F					
Head 4S-TFP-D80-18-11V-6F	6	54	80	100	76
Base 4S-TES-D80B-59-32R-11V-6F					

CONTACT US



MEGA TECH METALWORK CO.,LTD (Headquarter)



Tel : 02-943-1591



Fax : 02-943-1592



Line ID : @mgt_metalwork



Email : sales.m@mgtg.co.th



Web : <https://www.mgtg.co.th/>



**17/4 Soi Ramintra 89
Ramintra Khannayao
Bangkok 10230**

