

NEW PRODUCT NEWS



Taegutec Milling Line

CHASE4FINISH

HIGH FEED MILL

**NON-ADJUSTING SCREW TYPE FACE
MILL LINE FOR SUPER FINISHING**

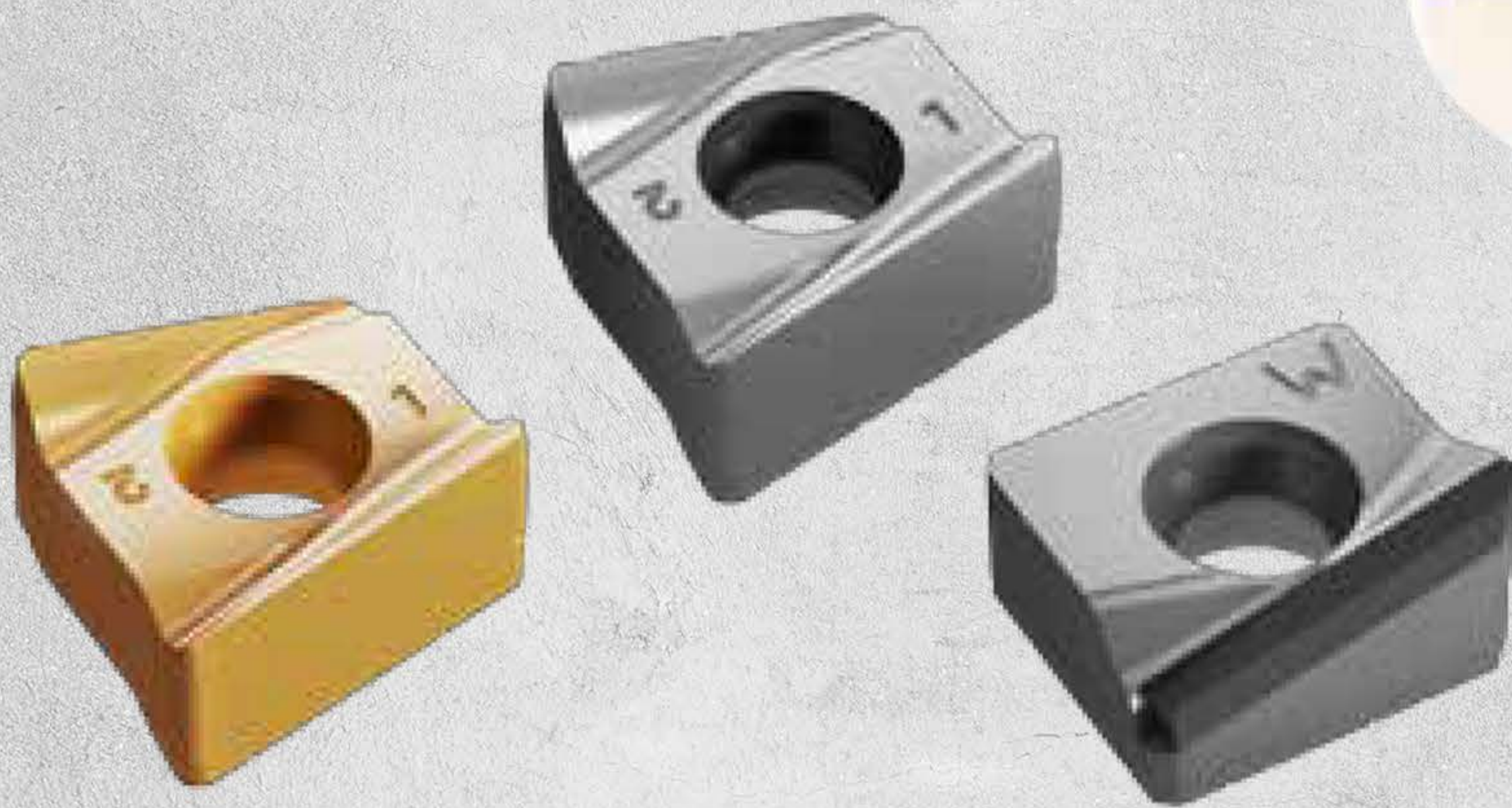
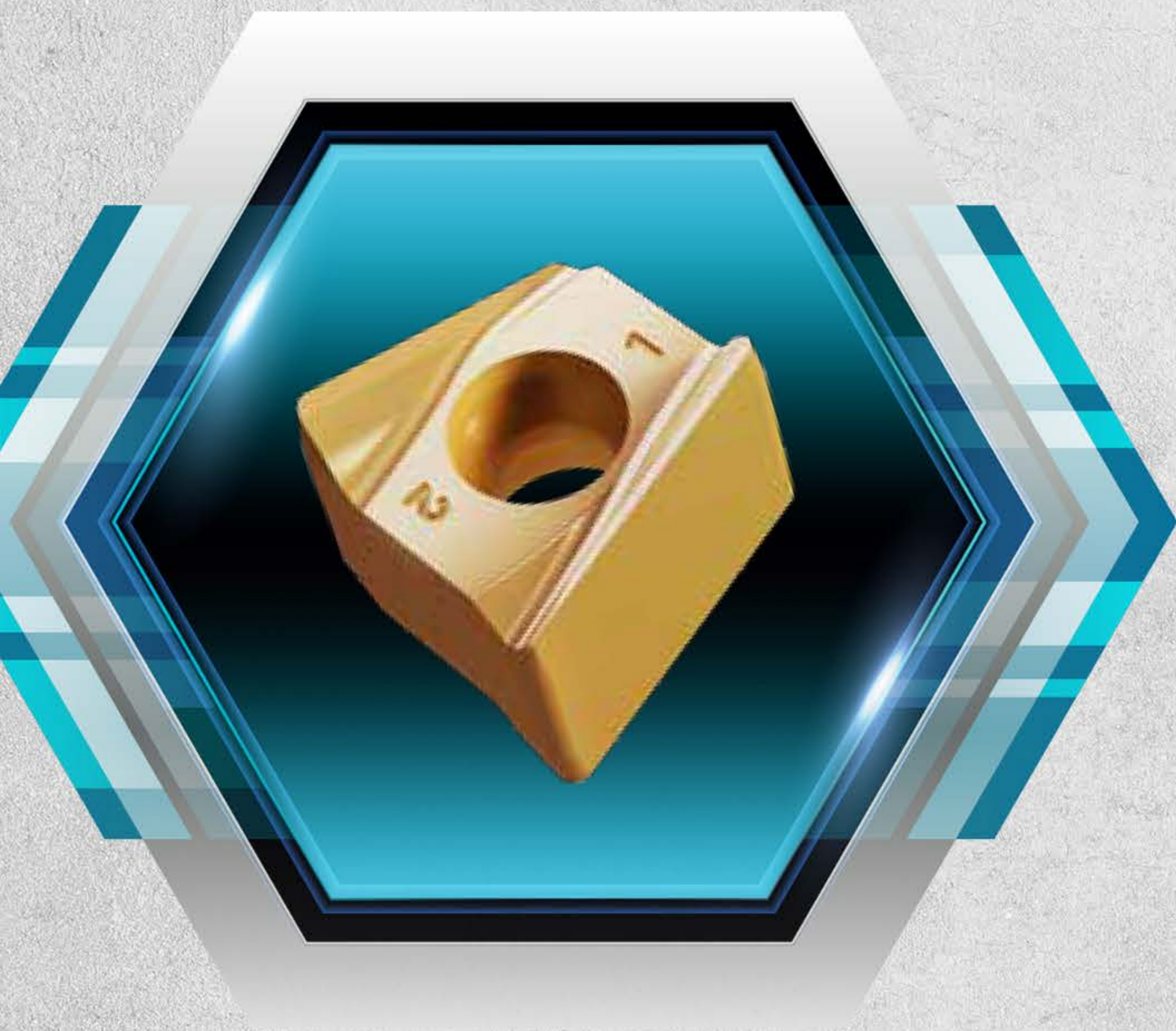

KEY POINT

Now available from TaeguTec, a double-sided 4 corner non-adjusting screw tightening 4WHU straightening insert and cutter line for super finishing.

The **CHASE-4-FINISH line**'s direct screw mounting system eliminates the required run-out adjustment of cutters for finishing, therefore eliminating the need for extra set-up time.

The arrangement of the cutter's unique cutting edges optimizes surface roughness while machining depths of cut of under 0.5 mm and reduces set-up time. The 4WHU's long wipers enable excellent surface roughness during machining. This insert line is especially suited for a variety of materials from steels, cast iron to aluminum. An additional benefit to the line is the insert's high axial rake angle, which improves tool life and chip evacuation.

Please contact TaeguTec's product manager for further questions.

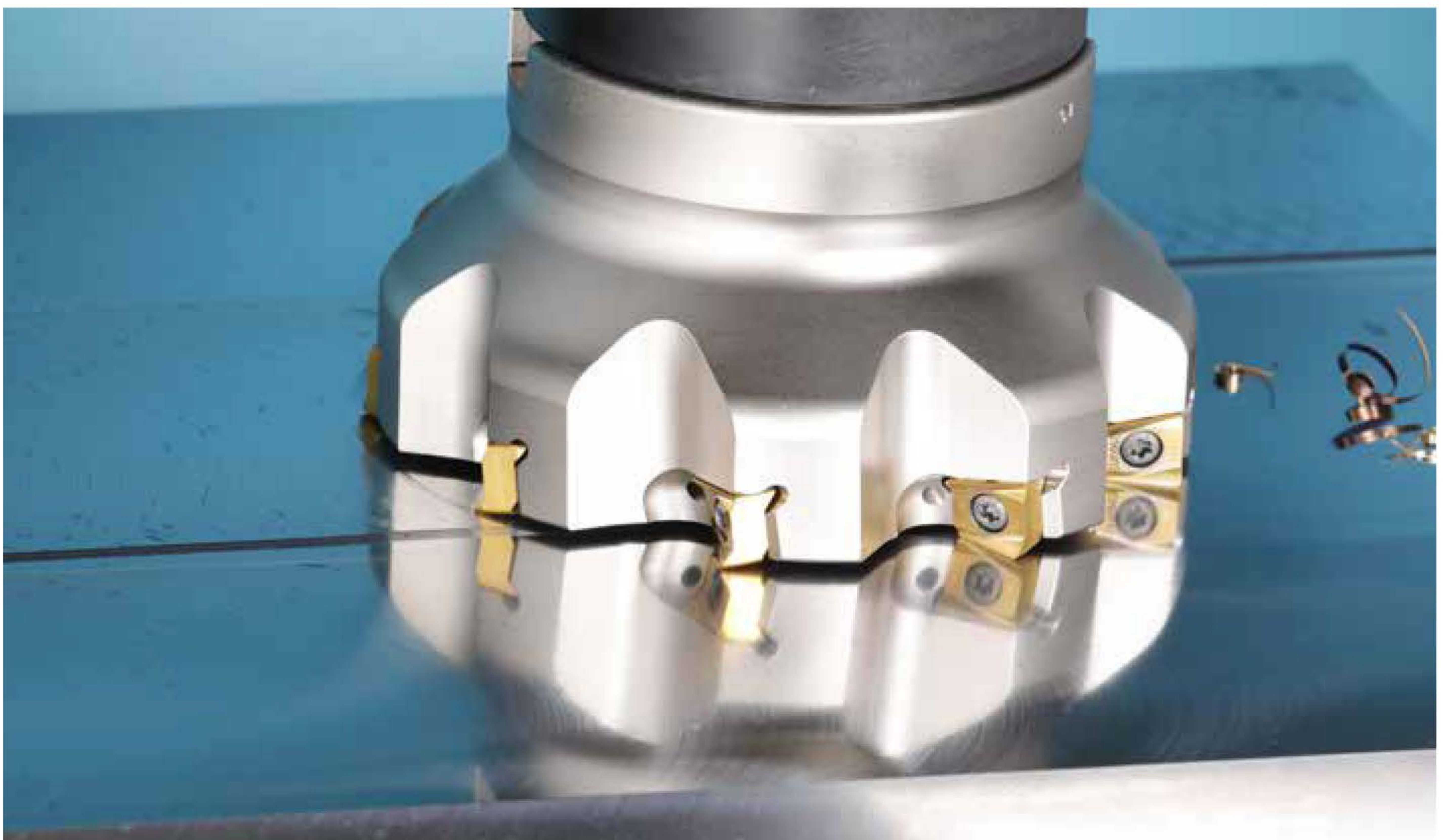

Taegutec Milling Line

Features

Insert

- Insert's high positive rake angle improves tool life and chip evacuation
- Insert's long wipers generate excellent surface roughness
- Double-sided 4 corners insert
- Insert line covers a wide variety of materials

Cutter

- Unique cutting edges arrangement for optimal surface roughness and increased tool life

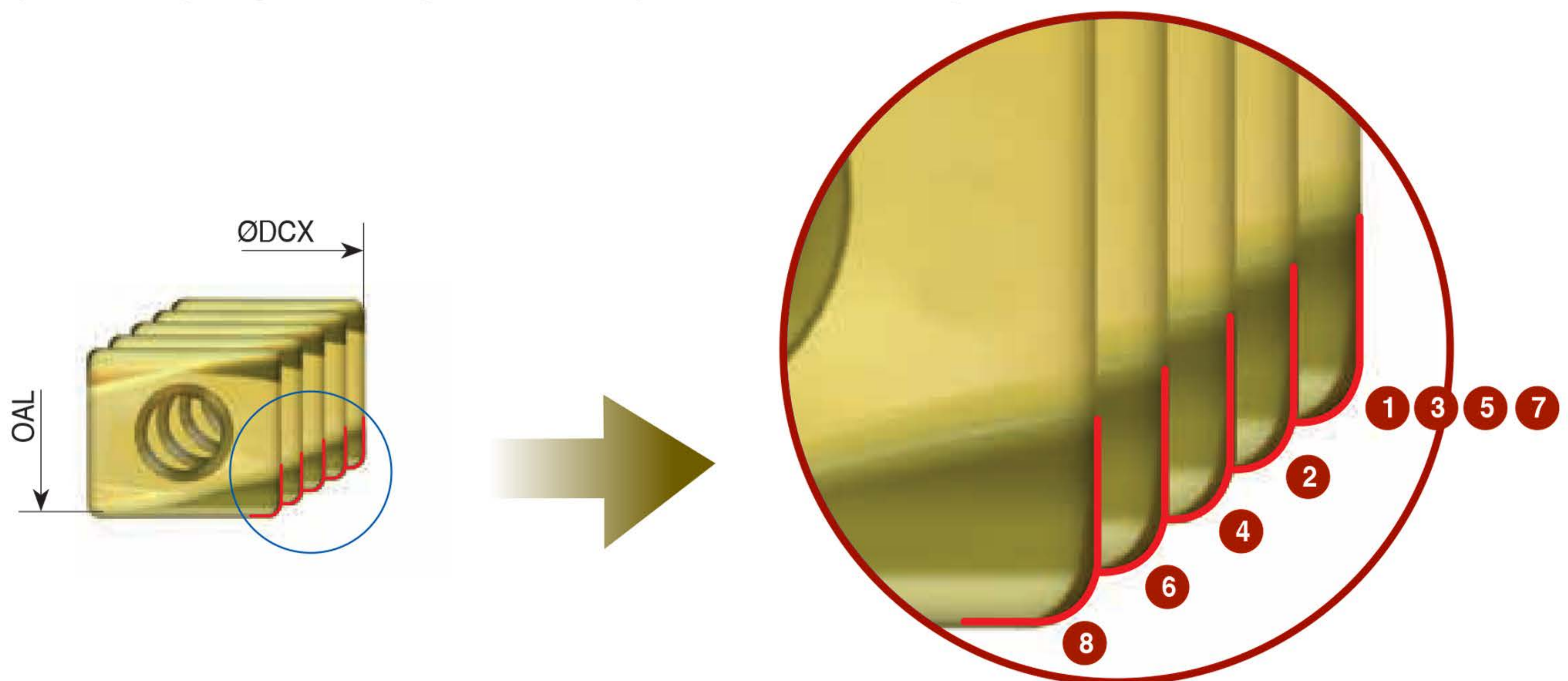

(Ex: Arrangement of cutting edges in Ø100 with 8 teeth)

- A non-adjustable direct screw type cutter means reduced setup time
- High positive rake angle ensures smooth chip evacuation

4W-TF90-12



Finish mills

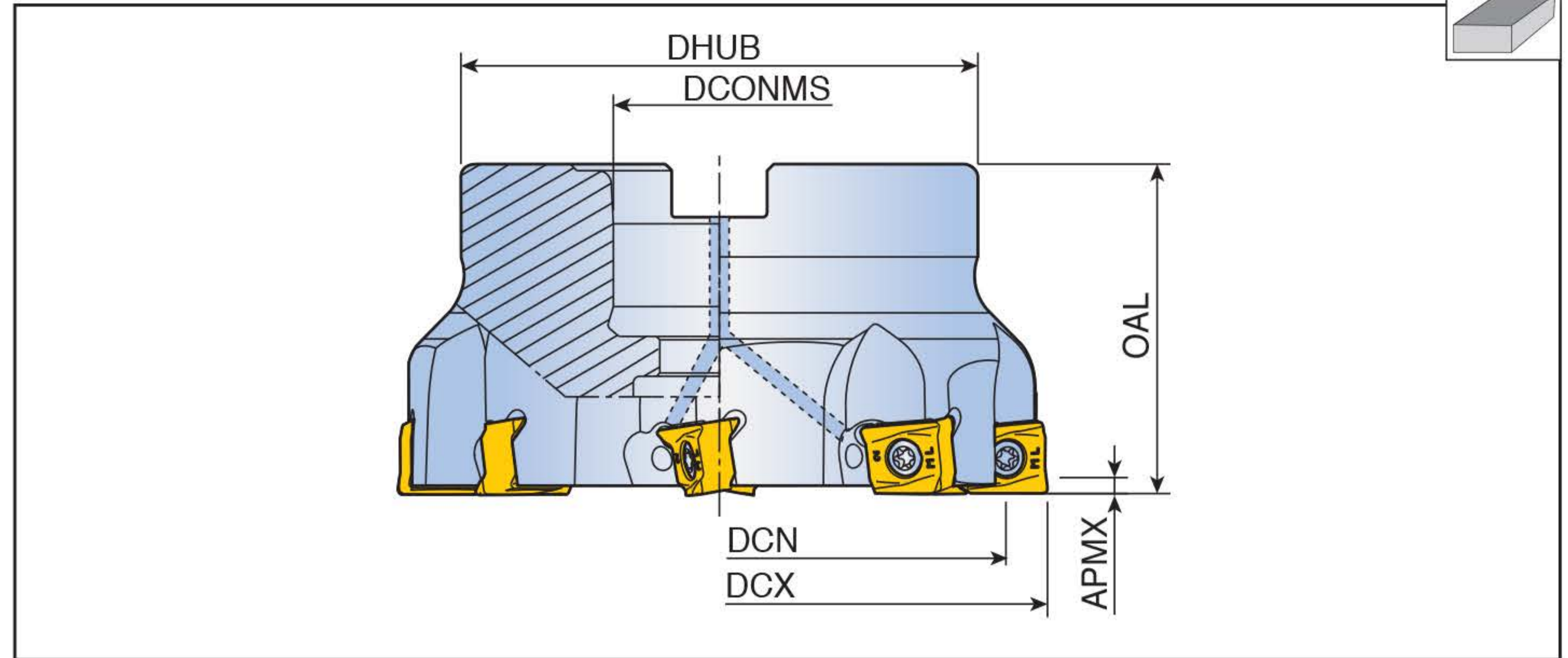

Designation	Z	Dimension (mm)						Coolant	Arbor type	Kg	Mounting bolt	Insert
		DCX	DCN	DCONMS	DHUB	OAL	APMX					
4W-TF90-550-22R-12	5	50	38.9	22	45	40	0.5	•	A	0.4	SH M10x30	4WHU 1207...
663-22R-12	6	63	50.9	22	47	40	0.5	•	A	0.5	SH M10x30	
880-27R-12	8	80	66.9	27	58	50	0.5	•	A	1.1	SH M12x35	
8100-32R-12	8	100	86.9	32	66	50	0.5	•	A	1.6	SH M16x35	
10125-40R-12	10	125	110.9	40	85	63	0.5	•	A	3.1	SH M20x40	
10160-40R-12	10	160	145.9	40	110	63	0.5	x	C	4.1	-	

- DCN: Cutting diameter minimum
- DCX: Cutting diameter maximum

Spare parts

Designation	Screw	Wrench	Wrench handle		
4W-TF90-12	TS 40A115I	TBLD T15-W6	SW6-T		

4WHU



Inserts

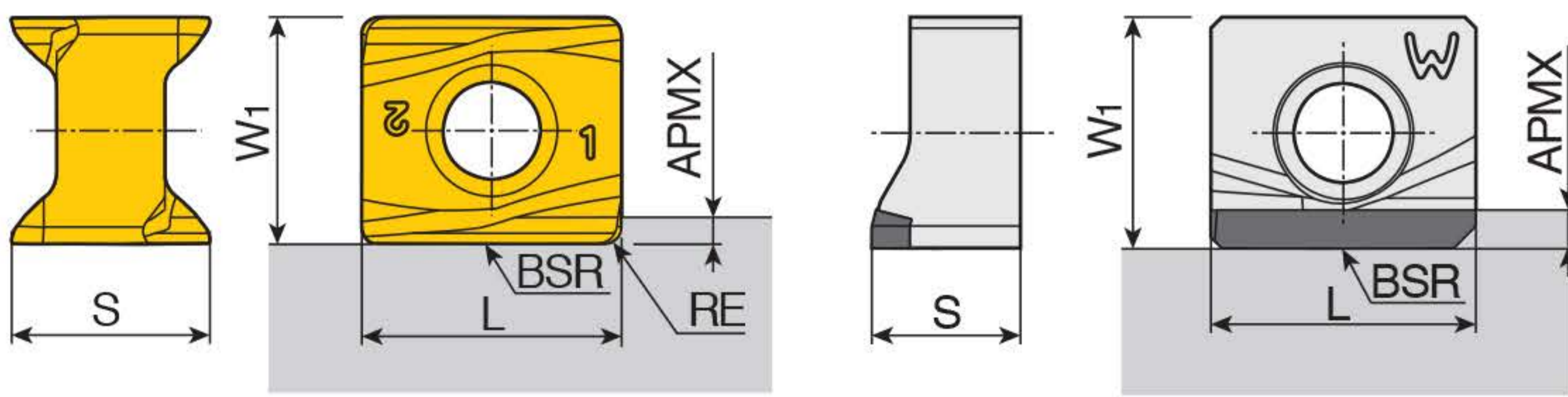

ML/AL

PCD / CBN

Size	Dimension (mm)					
	L	W ₁	S	APMX	RE	BSR
12-ML/AL	12	10.5	9.08	0.5	0.8	1000
12-PCD	12	10.5	6.74	0.5	-	1000
12-CBN	12	10.63	6.71	0.5	-	1000

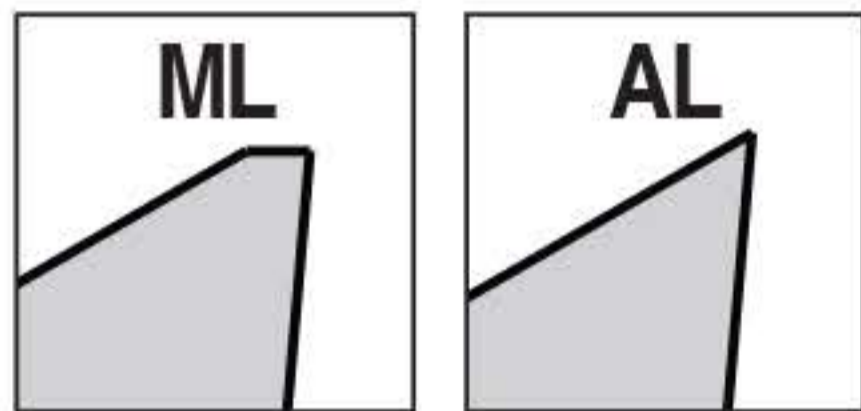

Insert	Designation	Recommended machining conditions		Coated					Uncoated		PCD	CBN
		ap (mm)	Feed (mm/tooth)	TT9080	TT9030	TT8080	TT8020	TT6080	K10		TD810	KB90
	4WHU 1207-ML	0.25-0.5	0.25-0.10	●				●				
	4WHU 1207-AL	0.25-0.5	0.25-0.10						●			
	4WHU 1207-PCD	0.25-0.5	0.25-0.10							●		
	4WHU 1207-CBN	0.25-0.5	0.25-0.10									●

●: Standard items

KIT COLLECTIONS

These kit products are available in the format listed below.



Cat. No.	Designation	Bill of materials	Qty.
6334799	KISFT-4W-TF90-8100-32R-12	4W-TF90-8100-32R-12	1
		4WHU 1207-AL K10	16
6334800	KISFT-4W-TF90-10125-40R12	4W-TF90-10125-40R-12	1
		4WHU 1207-AL K10	20



Cat. No.	Designation	Bill of materials	Qty.
6337864	KISFS-4W-TF90-8100-32R-12	4W-TF90-8100-32R-12	1
		4WHU 1207-AL K10	50
6337865	KISFS-4W-TF90-10125-40R12	4W-TF90-10125-40R-12	1
		4WHU 1207-AL K10	50



Cat. No.	Designation	Bill of materials	Qty.
6338435	KISFF-A-4WHU 12-AL K10	4WHU 1207-AL K10	100
6338436	KISFF-B-4WHU 12-AL K10		300

CONTACT US



MEGA TECH METALWORK CO.,LTD (Headquarter)



Tel : 02-943-1591



Fax : 02-943-1592



Line ID : @mgt_metalwork



Email : sales.m@mgtg.co.th



Web : <https://www.mgtg.co.th/>



**17/4 Soi Ramintra 89
Ramintra Khannayao
Bangkok 10230**

