

NEW PRODUCT NEWS



Tungaloy Report No. 375S4-G

Threading tool

TUNGTHREAD

EXPANSION OF API THREADING INSERT



TUNGTHREAD

Double-sided chaser insert enables high productivity machining

New API standard round thread

T05TP

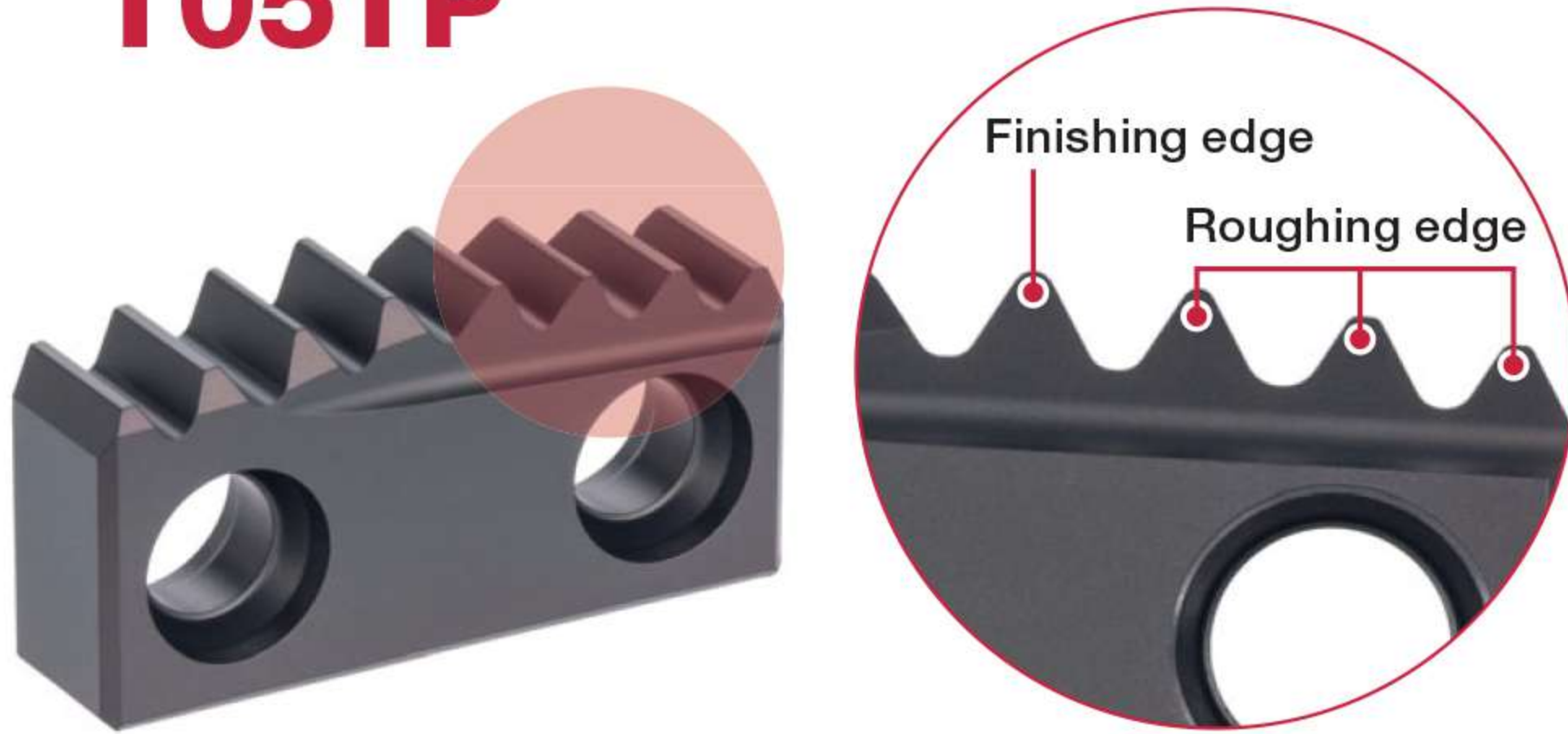

API standard buttress thread

T05HP

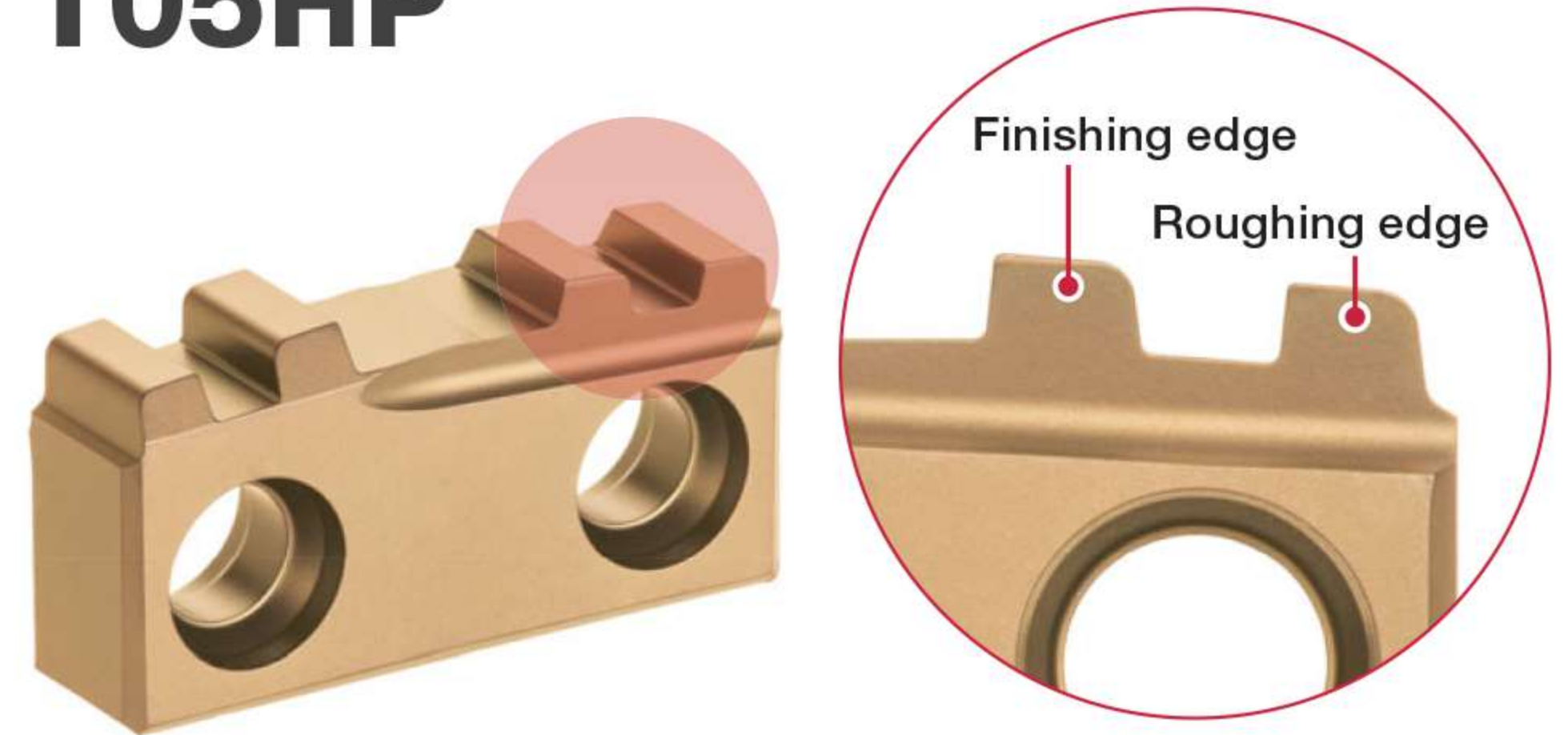

CUTTING PERFORMANCE

- New CVD grade T05TP applicable to various steel types in Oil & Gas market
- Excellent wear and chipping and welding resistance, achieves stable tool life and high accuracy threading

API standard round thread

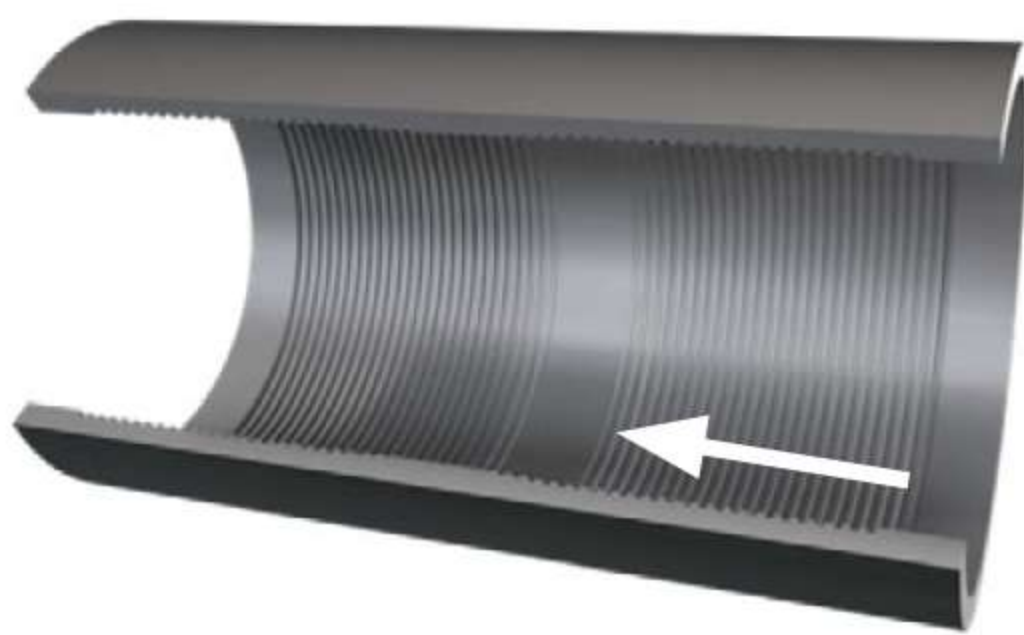

API standard buttress thread

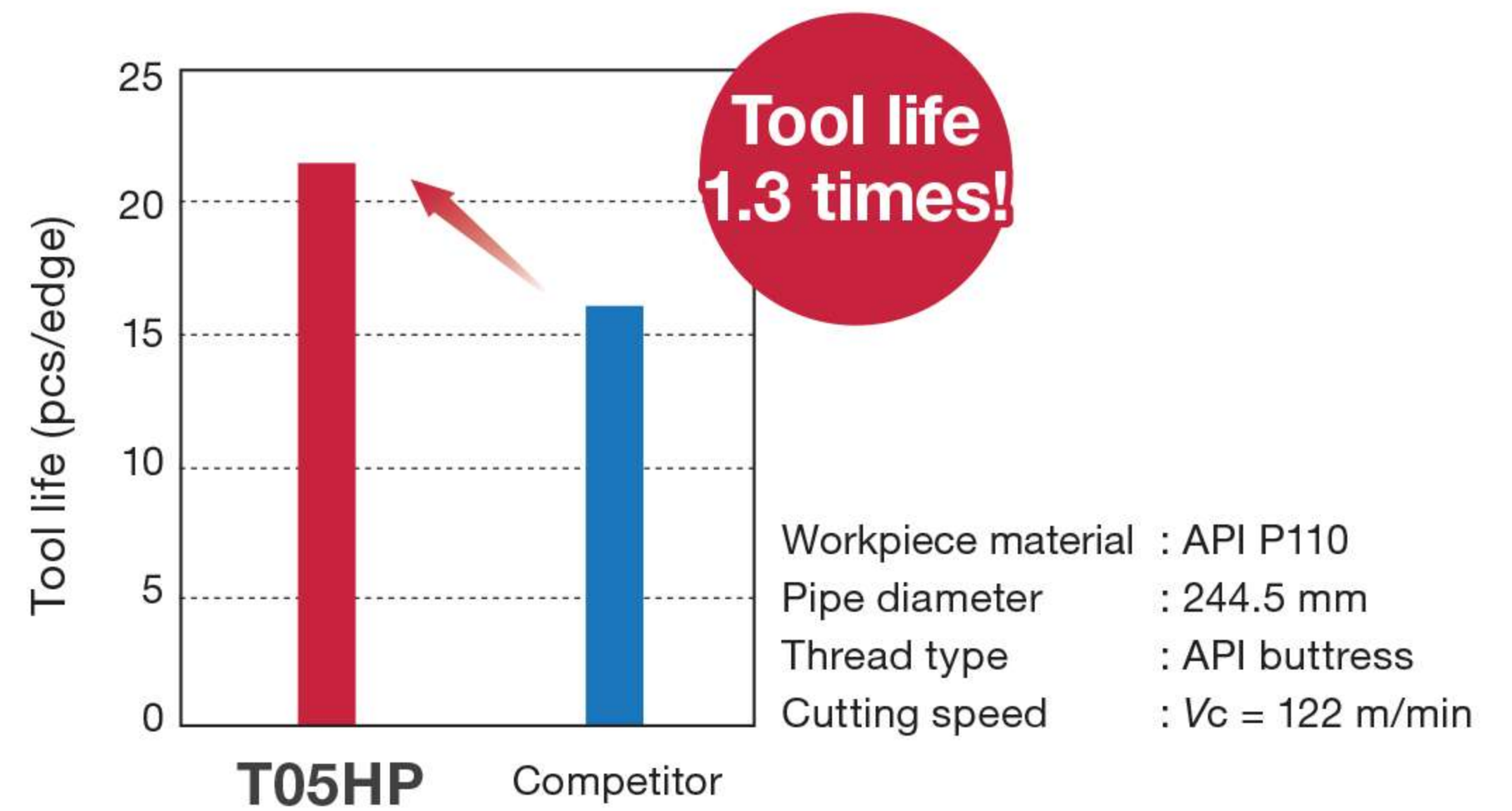
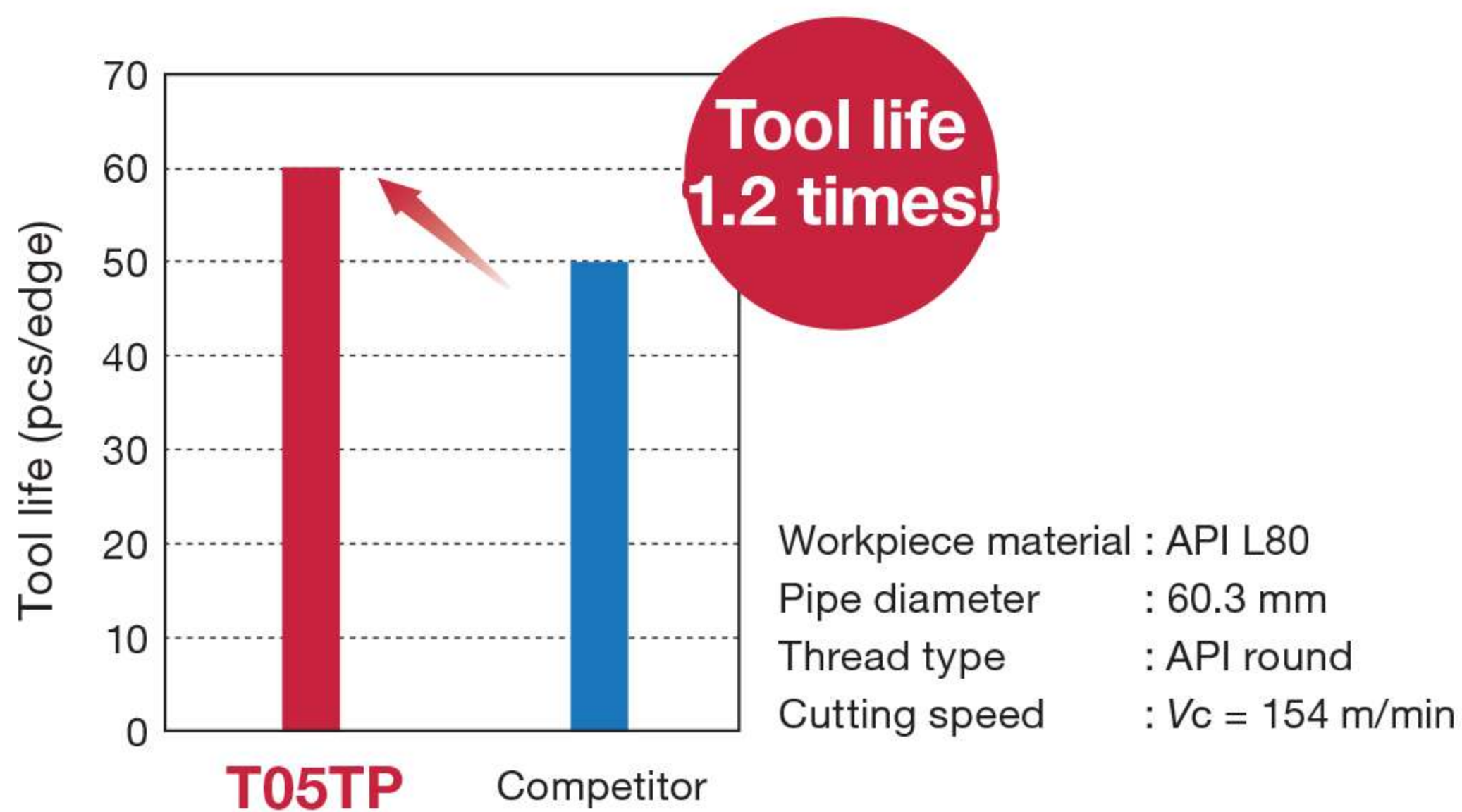
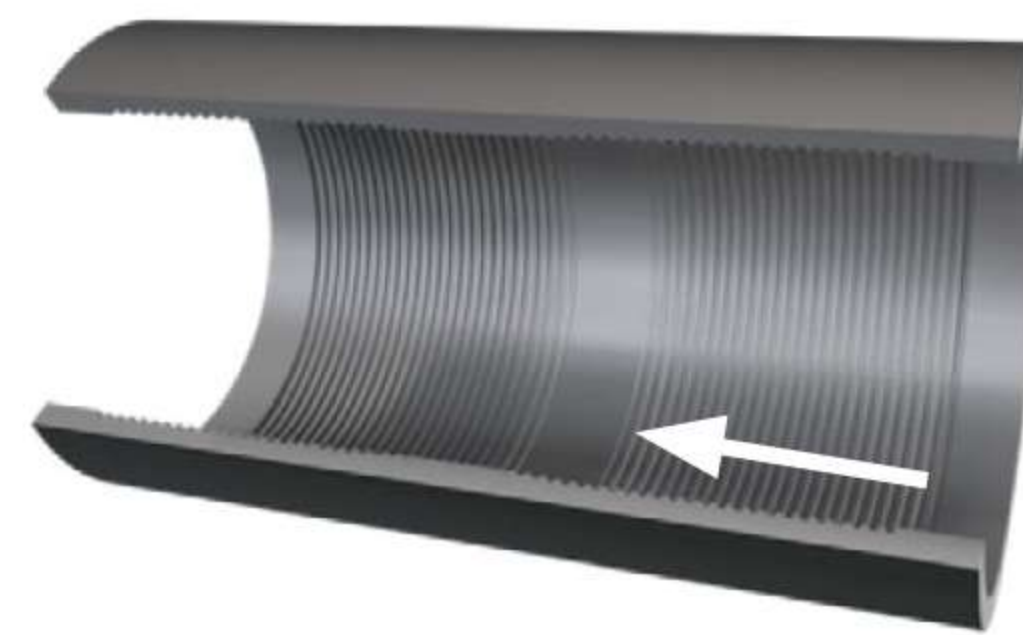

INSERT

API Round (for Energy)

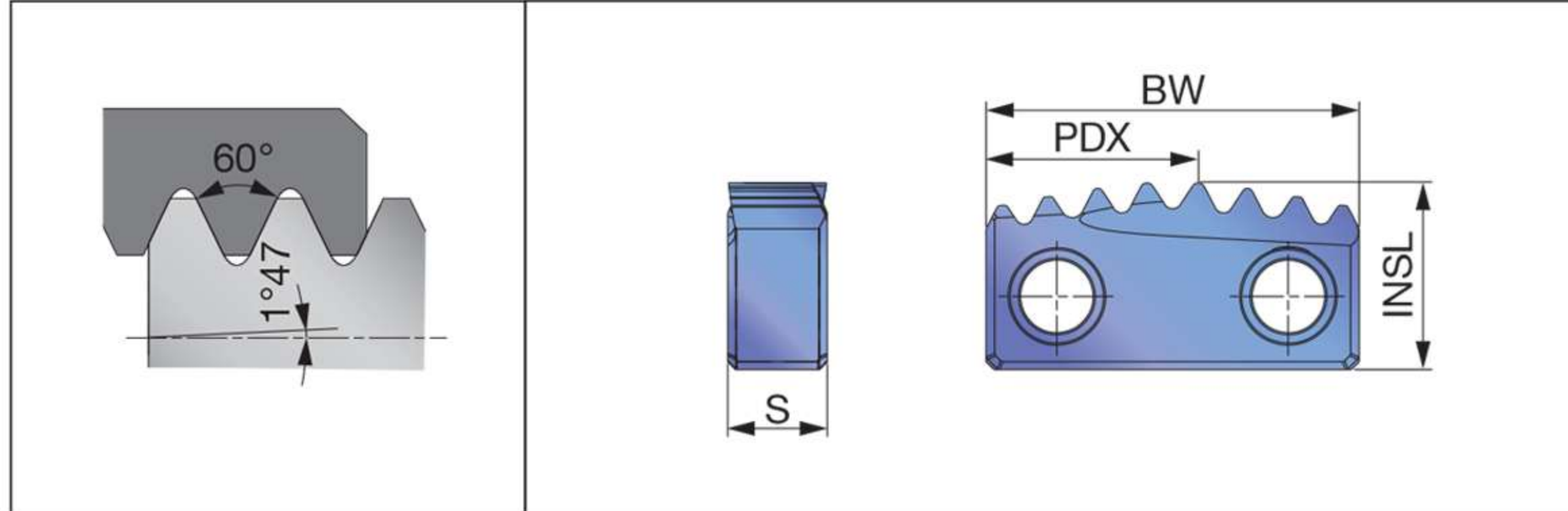

Full-profile insert

Insert size	Pitch (Reference)	TPI	Hand of cut	Internal insert					
				Designation	Grade	BW	INSL	PDX	S
22 (5.08)	5	R		CR-8R-4I-W24	T05TP	24	12	13.65	6.4

● : New product
Package quantity = 5 pcs.

Note: Toolholders need to be customized for these types of inserts.

API Buttress (for Energy industry)

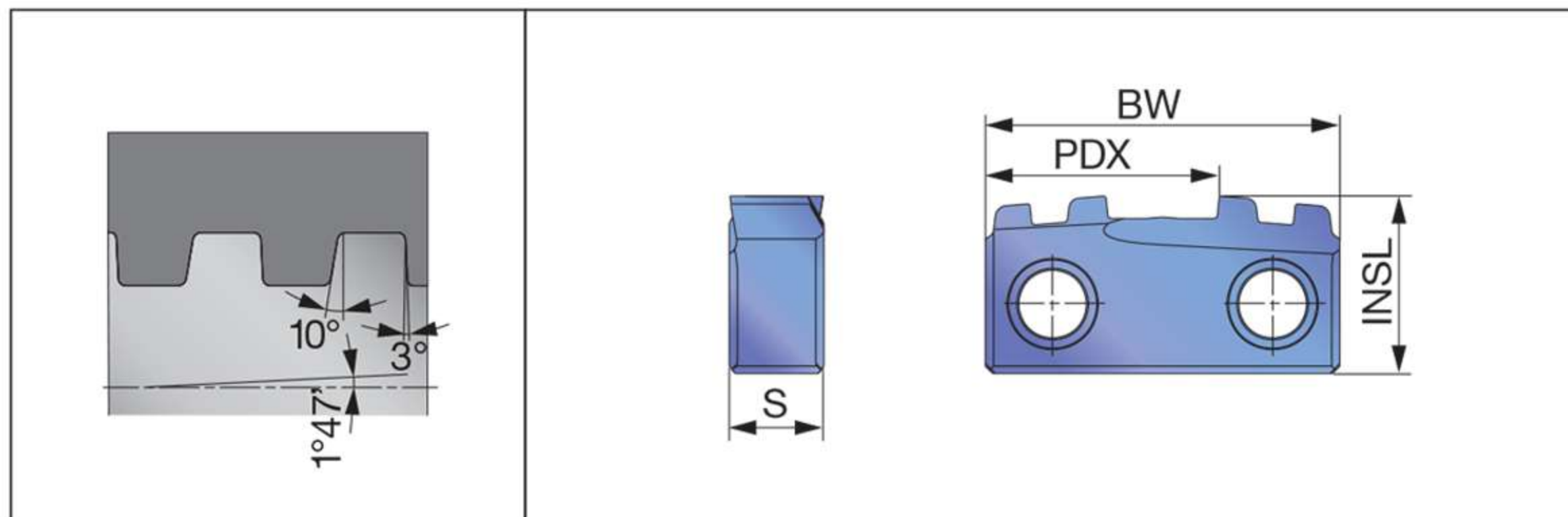

Full-profile insert

Insert size	Pitch (Reference)	TPI	Hand of cut	Internal insert					
				Designation	Grade	BW	INSL	PDX	S
22 (5.08)	5	R		CR-5B75-2I-W24	T05HP	24	12	15.85	6.4

● : Line up
Package quantity = 5 pcs.

Note: Toolholders need to be customized for these types of inserts.

STANDARD CUTTING CONDITIONS

ISO	Workpiece material	Hardness	Cutting speed: Vc (m/min)	
			T05HP	New T05TP
P	Steel / Alloy steel S45C, SCM440, etc. C45, 42CrMoS4, etc.	< 200HB	100 - 200	100 - 200
		> 200HB	100 - 150	100 - 150
M	Stainless steel SUS304, etc. X5CrNi18-9, etc.	-	70 - 130	70 - 130
K	Cast iron FC250, FC300, etc. 250, 300, etc.	-	70 - 150	70 - 150
N	Non-ferrous metal	-	-	-
S	Superalloys Ti-6Al-4V, Inconel718, etc.	-	-	-
H	Hardened steel	50 - 60HRC	-	-

CONTACT US



MEGA TECH METALWORK CO.,LTD (Headquarter)



Tel : 02-943-1591



Fax : 02-943-1592



Line ID : @mgt_metalwork



Email : sales.m@mgtg.co.th



Web : <https://www.mgtg.co.th/>



**17/4 Soi Ramintra 89
Ramintra Khannayao
Bangkok 10230**

